The NEMES Gazette

Vol 06, No 063
July-2001
© 2001

The Newsletter of the New England Model Engineering Society

Ron Ginger, President, 17 Potter Road, Framingham, MA 01701, Ron.Ginger@Compaq.com

Rob McDougall, Treasurer, 357 Crescent Street, Waltham, MA 02453, RCMcDougall@MediaOne.net

Kay Fisher, Editor, 80 Fryeville Road, Orange, MA 01364, Kay.Fisher@Compaq.com

Bob Neidorff, Publisher, 39 Stowell Road, Bedford, NH 03110, Neidorff@TI.com

Our next meeting is at 7:00 PM on Thursday
5-July-2001 (first Thursday of every month) at
The Charles River Museum of Industry
154 Moody Street
Waltham, Massachusetts

Annual dues of \$20 covers from Jan to Jan.
Please make checks payable to NEMES and send to
our treasurer. (Address in masthead).

Missing a Gazette? Send mail or email to our
publisher. (Address in masthead).

This Months Contents

The Editor's Desk.....	1
The President's Corner	1
Random Ramblings.....	3
The Meeting	4
Graham's Patent Locomotive Spring Balance	8
Treasurer's Report.....	9
Chestnut Hill Pumping Station.....	10
Metal Shapers	13
Calendar of Events.....	15
For Sale	16
Web Sites of Interest.....	16

The Editor's Desk

By Kay R. Fisher

A few months ago, we asked people to tell us if they would rather get the Gazette electronically. Has anyone requested e-mail copies of the Gazette? We haven't heard a peep from that recent question. If you desire electronic distribution via email please send email to our Treasurer – address in masthead. This month's issue has several really good pictures of the Chestnut Hill pumping station taken by Mike Boucher. To really appreciate the photographs you should visit our web site and look at this edition on-line. We seldom print in color because of expense but even then the copies don't usually do justice to the original photos. But our on-line editions are always in color.

Kay



The President's Corner

By Ron Ginger

Car Model Club

At our June meeting we had a presentation by 4 members of the MASS CAR club, a group dedicated to the construction and showing of model

cars. I won't comment here on the meeting, since I'm sure Steve will have his usual fine report.

That meeting was arranged by Mike Boucher and as part of the arrangement there was an agreement to do a speaker swap with them. So, on Wednesday June 20, Mike and I went to their meeting and told their members about model engineering. We each brought along a couple models, and Mike brought some typical plans and books as well as a casting kit. It was an enjoyable meeting for me, and I think their members were interested in our work. They have a strong interest in joining us for our outdoor show at the North Shore Antique Car show in September.

I was interested to see the emphasis they put on competition and judging. Their main event is an annual show where trophies are awarded in several categories. They even have a small local contest at each monthly meeting. There were about a dozen models in the contest the night we went.

They have another very interesting annual event. Each modeler seems to develop a specialty-some will build muscle cars; others will focus on the classics. Each year in May they draw names then have to build and show the car selected for them. Apparently they take it seriously, but with a great deal of fun- many of the cars get built in very strange ways! They have a separate judging of these at their annual show. Sounds like a fun event, and one that helps everyone broaden their outlook on models.

As with so many of the talks we have had at our meetings, I very much enjoyed this look at another hobby area I might not have thought much about before. I saw some interesting work, and more importantly, a good bunch of folks having a good time-sharing their hobby.

Steam Engine Kit

I mentioned at the May meeting that I had purchased a nice engine kit at NAMES, and have had requests for more details, so here it is. There is a series of 4 kits by an Australian company:

Miniature Steam Pty, Ltd.
PO Box 840
Mulgrave Victoria 3170
Australia.

The kits are of a horizontal and a vertical engine, in both a one and two cylinder version. They are very much like the Stuart Turner D-10, V10 and a small mill engine. The castings are all very fine, investment (lost wax) cast in some bronze alloy. I have not machined one yet, but they sure do look good. Some of the smaller parts like the reverse links and handle look like they will need nothing but a couple holes drilled and will then be ready to use.

The kits are sold in the US by:

Sulphur Springs Steam Models, Ltd.
PO Box 6165
Chesterfield MO 63006-6165
Phone 636/527-8326.

The single cylinder Vertical kit with reverse gear is \$135.

July Meeting

The July meeting will be a poster session, plus a talk by Dave Robie and Todd Cahill about Metal Spinning. Dave has requested that anyone who does spinning to bring some samples and tools or dies they use to the meeting. The meeting will take place on July 5th, which in addition to being the day after the big holiday is also the first Thursday of the month.

August Meeting

In August Bob Cline will tell us how to get the 30,000 horsepower steam plant up and ready to go on a WWII destroyer. The destroyer had two of them.

Ron



Random Ramblings

By Max ben-Aaron

Explosives – Part 1

The anniversary of the Oklahoma City bombing started me thinking about explosives, but not in destructive mode. I was, once, for a short time a shooter on an oil exploration seismic crew, which means that I prepared the explosive charges that were put down the shot holes to produce seismic waves. It left me with a very healthy respect for explosives, and first-hand experience of the dangerous potential for silly but fatal mistakes. The only defense is rigorous, obsessive adherence to proven safety procedures. I suppose that the same lesson applies to working with machinery and, especially, with electricity.

Explosives have been known for a thousand years. The Chinese are said to have used them for fireworks in the tenth century. Firearms, which use the gases developed from confined explosions to propel projectiles, have had a powerful effect on the course of history for about seven hundred years. Commercial blasting was an important factor in opening the American West - particularly in railroad construction.

Chemically speaking, an explosion is a rapid form of combustion. The principle difference between an explosion and a fire is the rate at which they take place. In fact, if you spread out dynamite in an open field and light one corner, it usually will burn like any other fuel (CAUTION: Do not try this at home unless you are Dave Stickler.)

When, however, you pack the explosive material tightly together and expose it to flame, it

explodes. It is the difference between a sigh and a cough.

Though many substances in many forms can and do explode - including gasoline vapors, hydrogen and finely dispersed dusts like coal dust and grain dust - only substances specifically formulated to explode are usually called explosives.

According to the Du Pont Blaster's Handbook, an explosive has three basic characteristics:

1. It is a chemical compound or mixture that can be ignited by heat, shock, impact, friction or a combination of the above.
2. Upon ignition it decomposes very rapidly in a detonation -- as opposed to a deflagration, which is a slower decomposition. Note that "deflagration" means "a slow explosion"; it is not a fancy word for fire. An arbitrary figure of 3000 fps (915 m/s) is usually considered the dividing line between a deflagration and a detonation.
3. Detonation causes a rapid release of heat and large quantities of high-pressure gas, which expands rapidly with sufficient force to overcome confining forces e.g. the confining forces of a surrounding rock formation.

The use of explosives in mining, construction, quarrying, and demolition is well known. In fact, mining uses 70% of all the explosives and blasting agents produced in the United States. But there are literally dozens of other applications that are much less well-known, including seismic exploration, cutting of timbers, well shooting, blasting logjams, welding ordinarily dissimilar metals together, and, even, producing industrial diamonds.

In blasting for rock removal, the energy released has four basic effects: rock fragmentation, rock displacement, ground vibration and air blast. In general, one of the first two, fragmentation and displacement is the objective of the blast; the vibration and air blast are unwelcome by-products.

An explosive, like a wrench or air drill is a tool; it magnifies the power that can be applied to a job. Unlike a wrench or other tool, the degree of

power magnification is almost beyond imagining, even though the power output is only momentary. But it is just this concentration of energy in a small, convenient package that makes an explosive such an extraordinarily versatile tool.

Mb-A



The Meeting

By Stephen C. Lovely

The Meeting, 7 June, 2001

We have a sound system for the meetings again. The first sound system that NEMES bought disappeared. Rob McDougall did some negotiating and worked with the Museum, and the Museum shared the loss with us. We also now have a locking cabinet with “NEMES” on it so things should stop getting lost.

Since we now have a cabinet, we can put some emphasis back on the NEMES Library. We had one in the past but with nowhere to store books and tapes it sort of faded away.

Museum Security is an issue. The door we come into meetings by can't just be left open and unattended during meetings. It also isn't fair to ask a member to sit down by the door and miss the meetings. The answer is Tom, an official Charles River Museum of Industry volunteer who will man the door on meeting nights from 6 to 9 PM. It will cost NEMES something for this, but we don't pay most of our speakers so the Treasury will be able to cover it without strain.

The June meeting is the official Annual Business Meeting of NEMES (after all, we are a

genuine Massachusetts Corporation.) Just about the only business that we need to conduct at the Annual Meeting is the election of officers for the following year. There wasn't much competition for the nominations, and the following slate was voted in when the current secretary (me) cast one vote for the slate based on the unanimous voice vote by the members present. Officers of NEMES for the coming year are:

- President Ron Ginger
- Treasurer Rob McDougall
- Vice President Steve Cushman
- Secretary John Wasser
- Board Member at Large Mike Boucher

Mike Boucher contacted Rich Sabol about doing some NEMES T-Shirts and he had two sketches of proposals for designs that Rich had sent him. I liked them both. The question was did we want to go ahead with one of them? Rich is willing to do the artwork for a nominal fee (it's how he makes his living so he can't just give it to us) and to then supply the shirts at a very good price to NEMES. There was a lot of interest in buying the shirts, so Mike will be asking Rich to go ahead with a final design. Other than changing the locomotive on the design to some other model engineering sort of image we decided to leave it up to Rich. After all, he's the artist and he does nice shirts (I think I've got at least a half dozen of his t-shirts and when the NEMES shirt comes out I'll probably get a couple more.)

In the early 1960s, Bliss sold drawings of British Naval Guns. Henry Szostek brought in a photocopy he's had made for \$5 of one of them, a “C” size drawing of a 32 lb. muzzleloader done by Harold Underhill of Glasgow. They haven't been available for years and Henry had the copy because someone had requested that he make them one so they could make a model. What Henry would like to know is, does anyone else want copies of any of the canon drawings he has, or does anyone have a less expensive place to get “C” size drawings copied than by going to a copy shop and paying \$5?

Don Strang brought in a book he'd come across, "Corrosion in Action" which explains a lot about the mechanisms that cause dissimilar metals to corrode, and even the same metal to corrode when different parts of the same piece are at different potentials. It has all the details explaining the mechanisms that destroyed the stainless steel barbecue grill that Henry Szostek brought in at a recent meeting.

Don also found some info on a single-phase variable frequency phase inverter. He frequently gets asked why they aren't available, since the 3-phase inverters work so well. The answer is that single phase motors tend to cog when they slow down. This is the noticeable pulsing of the torque as the single phase power curve goes from full power to nothing and then back again as the motor rotates. There is also the problem that the typical single-phase motor we deal with has a centrifugal starter switch. If you slow the motor down very much then you have to do something to keep the starting coils or capacitors from kicking in at the low speed. So, for split phase or shaded pole motors you can use them, but even with them you will see cogging at low speeds that never happens with the continuous power of a three phase motor running on 3-phase power.

Frank Dorian asked about using a 25 horsepower 3-phase inverter to power more than one motor in a shop. The answer is that you can, but you have to be careful. One of the main advantages of using an inverter to power an individual motor is that you can get a soft start. Without the soft start a motor can easily draw 5 or 6 times the normal operating current to get it going (this is why a motor will burn itself up if you overload it and it sits there instead of spinning when you power it up.) If you have a big enough inverter that it can handle the surge as an additional motor is started everything should be fine. If your inverter isn't big enough to handle all the current then you have a big-time problem and probably need a new converter. Since determining exactly what is going on is complicated, inverter manufacturers say to use one inverter for one motor – that way you get the advantages of a soft start and they don't have to worry about problems from fried equipment if

something wasn't quite right with the set up for running more than one motor at a time.

Ron Ginger highly recommends variable frequency inverters. You can use one to power an entire one man shop by wiring it up so that you can switch the output from motor to motor around the shop depending on what machine you are going to run next. Larry Twaits has done this quite successfully using a rotary switch. Larry did it a couple of years ago, when inverters cost quite a bit more than they do now, and Ron feels that as the price of inverters has come down it is not worth it to do all the wiring needed to switch one inverter to multiple machines.

Don Strang pointed out that a 5-horse motor with the proper run capacitors used as a rotary converter will run several motors and can be put together for practically nothing.

The Confederate submarine CSS Hunley was recently raised. It went down during the Civil War after the first successful torpedo attack from a submerged submarine. The captain of the Hunley was known to carry a lucky gold coin with him. It was doubled over from when it stopped a bullet that would have otherwise killed him. The coin was found in the Hunley as they are taking the Hunley apart for study and preservation.

Leon Schiff did some checking on the big steam engine off Harrison Ave. in Boston. It is in the former powerhouse for the West End Street Railway Co. Back when it was used, the Fort Point Channel ran up to where the coal pile was, an auger took the coal under the street to the powerhouse, and the engine powered a dynamo. The engine is still there.

The main speaker for the evening is Tony Mazzola, president of MassCar Model Club.

Tony started out by introducing some of the other MassCar members who had come to our meeting, bringing some pretty incredible model vehicles (I can't say cars, because one of the models was a Cement Truck.) MassCar is involved with scales from 1/43 to 1/8 of full size. Vehicles, and dioramas are both part of what MassCar members build.

The tools Tony uses are mostly hand tools. To protect the working surface he uses a mat, the same way that an artist or illustrator would – the typical smooth self-sealing sort of thing that you put on a drawing board. Sandpaper is glued to Styrofoam meat trays to make sanding blocks. He's got a big assortment of needle files. Nippers are used for cutting the plastic parts of a kit free from their sprues, and then the stubs are carefully carved away with an X-Acto brand knife blade. He also uses glue, clamps, and lots of body putty.

One thing that the model car folks use a lot that I think might be of benefit to NEMES members is a food dehydrator. They buy the standard \$15 or so unit sold to make beef jerky and apple rings and etc. and use it for drying paint and body putty and such. If you paint a model with an enamel paint and put it on the shelf to dry, it'll be a week at least before the paint is hard enough to polish without gumming up and making a mess of things. Put it in a food dehydrator overnight and you can polish it the next day.

Styrene plastic sheet and extruded shapes are available in hobby shops in a variety of thicknesses and shapes. They are used for raw material when customizing a plastic kit (known as "kit bashing") or when scratch building a model (building one without using a kit.).

Acetate plastic was used in the first plastic model cars. They were complete cars that dealers gave to the kids to keep them occupied while they worked on selling the parent the real thing. In 1954 Monogram produced the first plastic car kit. It was a midget racecar and was made of acetate. The problem with acetate is that, with time, it tended to change shape, distorting the model cars into things that didn't look quite so much like the cars they were originally. In 1956 or 1957, the entire plastic model industry switched over to Styrene. Acetate had the advantage that you could paint it with the lacquer type dopes used on model airplanes, while a styrene model would dissolve in the dope as you painted it.

Tony is currently working on many models at the same time, and hopes to eventually finish some. Meanwhile he's having fun and that's what

the model car club is all about. One current project he showed us is a model Plymouth Barracuda. The Barracuda is an older kit. The entire bottom of the body and the chassis of the car are a single molded piece and Tony is not happy with the detail. It's blobby and generally doesn't look that much like the bottom of a real car. New model kits have much more realistic chassis, with many separate parts to be assembled onto the bottom of the car by the builder. He can't get a new Barracuda kit, but he can get a new kit for a Dodge Dart, which has a chassis very similar to the chassis of a Barracuda (both are Revell kits and both are Chrysler "A" body cars.) So he is combining the two kits to use the Dart chassis under the Barracuda to get the realistic model of a Barracuda that he wants.

Tony also treats the individual parts that he puts into the car as models in their own right. Therefore, the engine that he will put into the Barracuda is made up of an alternator model, a distributor model, etc. with each one as detailed and as correct as he can make it.

Like every other hobby, the future is in the young people. The youngest MassCar member is 8, and the oldest is probably in his late 70's. They have shows, and try to get everyone interested, involved, and doing things. They have shows where the models are judged. The cars are judged on the craftsmanship, not on what the modeler intended.

The cement truck Stu Marcus built took him 2½ years to complete. It is made from parts of several different kits. It's an Autocar A64E with an International mixer on it. He spent 4 months building the chassis, and went to a Caterpillar dealer to get the authentic yellow paint to paint the engine.

As time has gone on, there have been more and more aftermarket model car parts made available by suppliers. Today you can buy a set of multi-piece aluminum wheels for your model for about \$50.

Tony is building a modified '57 Chevy kit. Its premise is that he's building something that GM might have presented at the Autorama. He has cut it in half and lowered it and also cut it in half the other way and shortened it. Then he cut the fins off and

reconstructed them from sheet styrene using glue that melts the new plastic into the old plastic so that it's essentially welded together. After the surgery on the body he uses putty on it, puts it into the food dehydrator, and can work on it after an hour. Without the food dehydrator things go a lot slower, having to wait overnight after using the putty.

The '57 Chevy has a long way to go before it's finished, but I was impressed. It reminded me of something by George Barris from the car magazines when I was a kid.

Another model Tony showed us was a Chrysler 300 kit. First he used steel wool on the body to get rid of all the blemishes and mold marks. Then he put floral foam inside the body to provide support for it and carefully cut the doors open with a knife. A small piece of tube and a paper clip are used to make a hinge. When you modify a kit that way to make the doors open you also have to do something to provide the interior surface of the door as well, since the body kit only takes care of the outside.

For chrome you can use cheap aluminum foil – cheap foil is thinner so it's better for use as a coating over the plastic parts. You can also buy "Bare Metal Foil" which is sold for use on models and comes with the glue already on the back. You can also have parts vacuum aluminized. Tony sent some parts out to ChromeTek and had them done. He paid about \$14 to get a 6 by 8 inch panel of parts aluminized.

Decals can be made by printing with a laser printer onto decal paper. The printing is done on the glue side of the paper and then the printing is lacquer coated. Then it is cut out and used like any other water transferable decal.

RTV silicone rubber is used for making molds from originals that are made out of whatever is convenient. Plastic, metal and other materials can be used. The originals can be turned on a lathe or carved, then assembled into complex shapes. The silicone molds don't require perfect parting lines since the RTV is somewhat flexible. Finished model parts are then cast from epoxy resin.

For masking models when painting, masking tape isn't used. It's too hard to get a good edge with it. Instead, artist's friskit film is used for masking.

Jim Cunningham likes to build classic car models with wire wheels. He brought a model of a 1928 Mercedes that he had put wire wheels on. The wire wheels were impressive looking. To make them, you start out with half a rim and half a hub. The two parts go into a jig and wire is wound between the two parts, forming the entire inner row or all the outer row of spokes in one continuous length. When both halves of the wheel are done they are glued together and the resulting wheel looks just like it had a whole bunch of individual spokes. Steel wire for the models needs to be buffed with steel wool to shine it up before use. When it's nice and shiny, lacquer it so it will stay shiny.

Airbrushing is a nice sophisticated way to paint models, but Jim uses rattle cans. Wait until everyone has gone to bed for the night, then put down paper in the bathroom where all the tile keeps the dust down, and spray the paint. Next morning it'll be dry and shouldn't have any dust in it because bathrooms aren't dusty places.

For interior carpeting the answer is flocking. Paint on a coat of thinned white glue (Elmer's brand typically) where the carpet goes and then dump in the flocking. Shake it around and then dump it out. When it dries you've got a nice looking carpet. Flock is available from vendors at model car shows and hobby shops. Model Railroad shops should have a good selection.

A company called Model Car Garage sells sheets of etched metal. All the chrome grills, emblems, and insignia you need for the particular model you are building are included. There are also clear sheets with all the instruments printed on them so you can paint the background of the gauge, then put the printing over the background you have painted. With all the variety of aftermarket equipment for models, you can easily spend \$150 on accessories for an \$8 model kit.

The most common scales for model cars are 1/24 and 1/25.

Do people pay big money for model cars? Brianza die-cast 1/43 scale cars are expensive. Franklin Mint and some of the other collectibles companies sell model cars for a lot more than an \$8 kit. Pocher 1/8-scale kits are imported by Model Expo and cost in the \$300 to \$400 range for the kit.

The next MassCar show is scheduled for April 21, 2002, and they have a monthly meeting. If you'd like to go to one of their meetings call Tony Mazzola (the current and fourth President of MassCar) at 617-776-4264 or check the MassCar website at www.masscar.com for more info.

scl

Graham's Patent Locomotive Spring Balance

By Stephen C. Lovely

In May our speaker was Stanley Gentry, who is building a full size replica of the Virginia & Truckee Railroad's Engine Number 1, a 22 ton 2-6-0 Mogul named "Lyon" built in 1869. One of the things that Stan mentioned in his talk was the Graham's Patent Locomotive Spring Balance that he is trying to find. Stan sent me more info on it, but I didn't get it in time to include it with the rest of the write up on the May meeting, so here it is now.

Stan and his wife want their replica to be as close a copy as possible. Some things can't be the same today as they were in 1869, if you are planning on steaming the replica and using it on mainline track.

As an example, the boiler is welded while the 1869 prototype was riveted. The safety valves are another place where the original 1869 equipment is no longer acceptable for use. Therefore, the plan is to have the engine setup in two separate modes. The first mode is for operation. In this mode, the locomotive will be equipped with all the latest FRA approved equipment and will be ready to head out on the main line pulling cars. In the other mode, it will be set up for static display with the original 1869 style equipment in place.

In 1869, the safety valves were controlled by a lever and rod arrangement that ran into the cab and connected to "Graham's Patent Locomotive Spring Balance". This was an adjustable device located next to the pressure gauge that allowed the engineer to control the pressure at which the safeties would open.

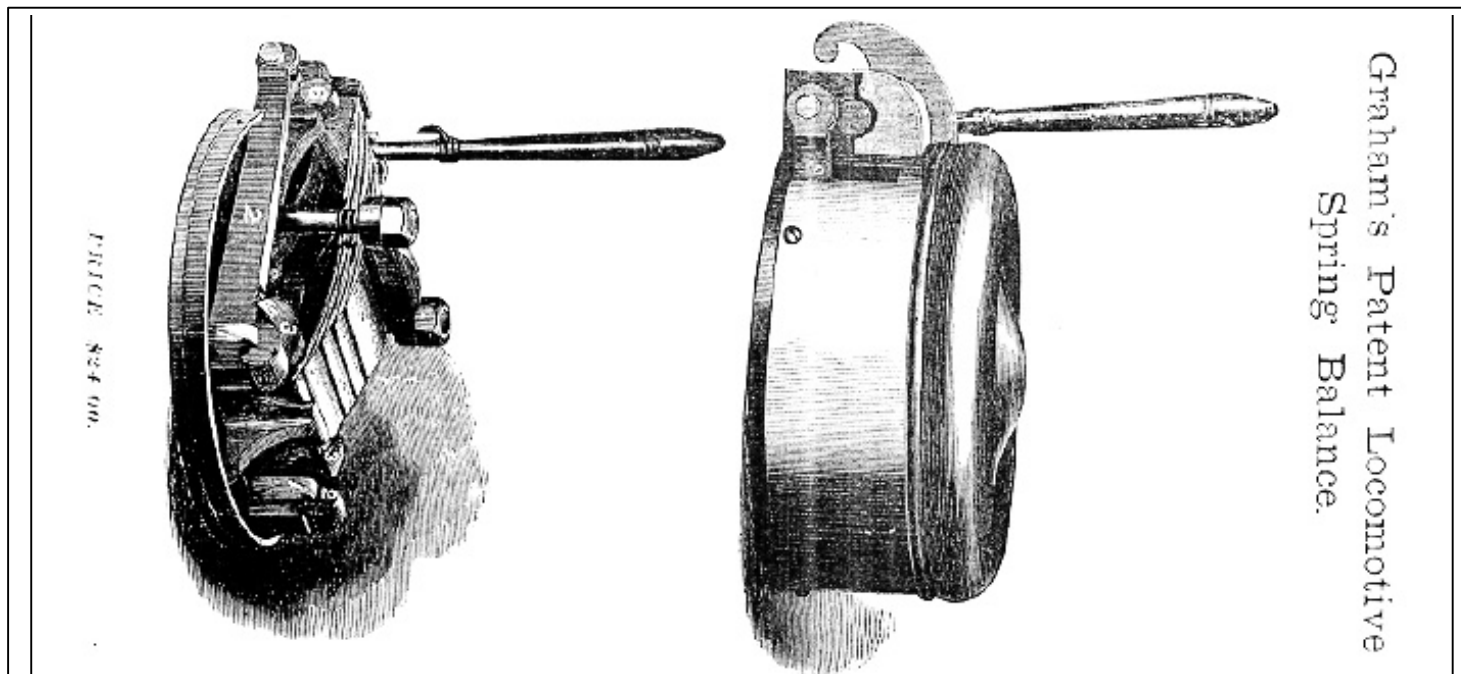

Graham's Spring Balance

Picture from an old catalog

The spring balance consists of a 5 leaf elliptical spring that holds down a pair of levers with a cross-bar that is under one end of the spring. An eccentric is under the other end of the spring and the whole assembly is held down by a bar over the center of the spring and two bolts. The eccentric is connected to a handle that the engineer can use to adjust the pressure where the steam blows off.

To adjust the spring balance, you pull the lever down so that the minimum tension is on the spring. Then fire the boiler and bring up the steam pressure on the gauge to the minimum point where you want to be able to blow off steam. Adjust the nuts on the two bolts holding down the cross-bar until the steam is just blowing off at that point. Mark the pressure on the scale. From here, you raise pressure 5 or 10 pounds at a time on the gauge and raise the handle until the steam stops blowing off and mark the spot on the scale. Continue until the handle is upright.

There is a lever on each side of Graham's Spring Balance, so that a single spring balance, using a single lever to adjust both valves, could control both safeties. It seems like a pretty useful design for an adjustable safety valve that you can easily control from the cab of a locomotive, but given all the stories I've heard about people who decided to tie down the safeties and get up just a little bit more steam, I'm just as glad that Graham's Spring Balance is no longer acceptable for use.

Graham's Spring Balance is the last thing that Stan needs to track down for the "Lyon" and he is hoping that one will turn up in someone's garage or that he can find someone somewhere to build him a replica. So, if you've got one in your collection that Stan can use on the "Lyon" when it's in display mode, or if you think you'd like to build him a replica, get in touch with him. You can reach him at:

Stanley P. Gentry
3430 East 13th Ave.
Hibbing, MN 55746
spgentry@aol.com



Treasurer's Report

By Rob McDougall

As of 5/31/2001

Balance as of 4/30/2001:	\$4,290.08
Dues Received	40.00
Interest Income	1.25
Less	
Gazette expense	-187.61
Guest Speaker Fee	50.00
Balance as of: 5/31/2001	\$4,093.72

Having just been swept back into office as your Treasurer with a landslide victory (and done on such a modest election campaign), I would like to take this opportunity to now spell out my campaign promises: "No New Taxes". I vow to keep up the good work of having our non-profit club not pay any income taxes. Now the bad news. I think we still may need to consider raising the annual dues at the start of January 2002. The question is how much? Our "kitty" in the bank, on an annual average run rate, I estimate to be \$2,200. This is about the same as last year, meaning, we are about breakeven. However, this leaves us little room to buy ANYTHING for the club without dipping into our savings. For example, we can't make donations where appropriate, or sponsor activities that might further the interests of our club and hobby. And I think we need a cushion. When it comes to collecting dues, nice round dollar notes are helpful, so I am proposing for your consideration, annual dues starting in 2002 of \$25.00 (checks always preferred). Please think about it, and let me know one way or the other your reactions. Probably, at the September meeting I will ask for a vote on this proposal by the membership.

Rob

Chestnut Hill Pumping Station

or A Fine Way to Spend a Saturday

By Mike Boucher

On Saturday, May 19th, many NEMES members went out West to Jim Paquette's swap meet. I however, being low on cash and close to Boston, chose to go East to a neighborhood that I lived during my college years. That neighborhood is Chestnut Hill, MA., home of the Eagles, and also the MWRA Chestnut Hill Pumping station.

There is a reservoir in Chestnut Hill, and next to the reservoir are two water-pumping stations built in the late 1800's to provide water to the city of Boston. Both buildings still contain their original reciprocating steam engines, the last of which operated in the early 1970s.

At a recent NEMES meeting, someone came to talk about the restoration of the buildings, and their upcoming conversion to commercial space. He also said that once a year there is an open house at the buildings. Having spent 4 years looking at the buildings but never seeing inside, I jumped at the chance to get inside. (Sorry, Jim, I'm sure you'll understand!)

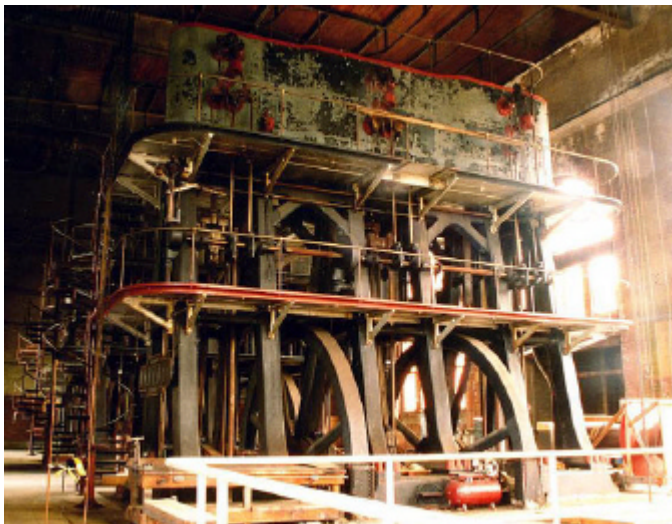

Chestnut Hill Photo 1

by Mike Boucher

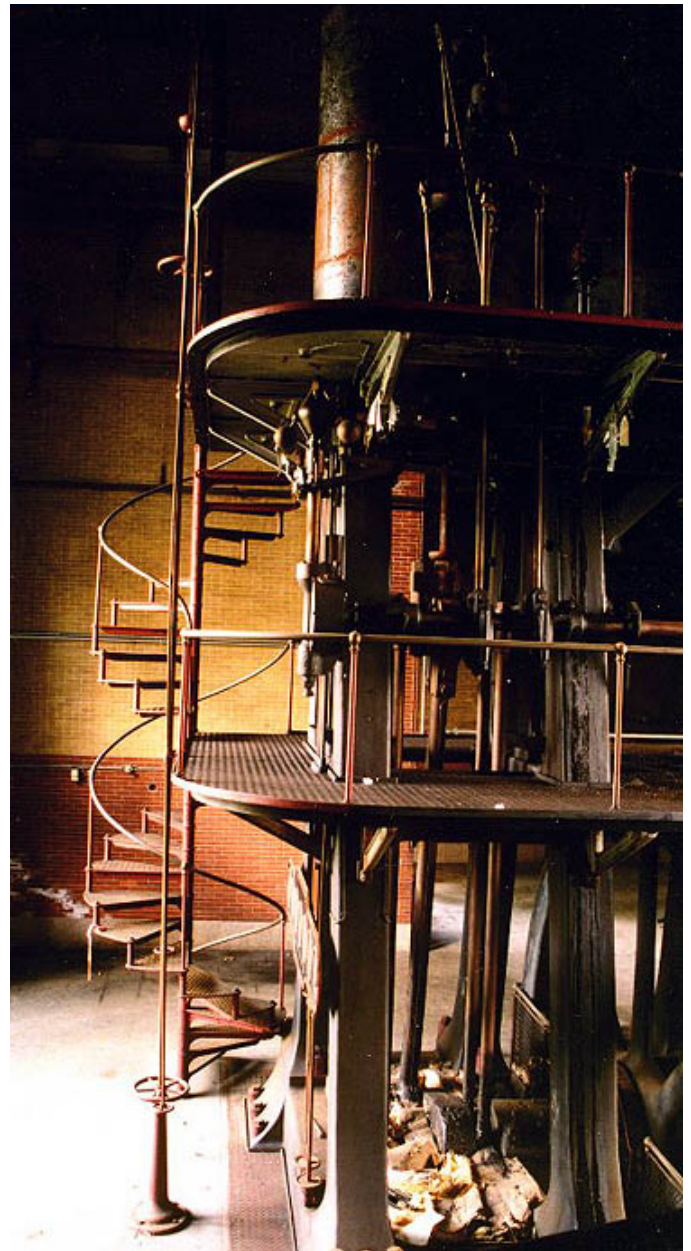

Chestnut Hill Photo 2

by Mike Boucher

The two buildings were built at separate times. The original one contained engines, which pumped at a low pressure. As Boston grew, a second, higher-pressure building was needed. The older, low-pressure building is the one on the left, a large marble-looking square building. The newer, high-pressure building is the one on the right, designed by an architect who studied at the Richardson school of architecture. (Richardson designed the Trinity Church in Copley Square, a Boston landmark)

When I first got there, there was a large group of people gathering outside the high-pressure building. I noticed that doors of the low-pressure building were open, so I let myself in. I was the only person in the building, and I was standing in front of three huge, matching triple expansion engines. I was awestruck. These could have been the largest engines I had ever seen, and there were three of them.

(As an aside: the engines at Kew Bridge in London are larger, single-cylinder beam engines, but you can't see the whole engine at once.)

I started a little mantra, "don't let anyone else come in here..." as I set up my camera and tripod. Photo 1 captures the scene. (For a sense of scale, look for the large red air compressor in front of the engine)

Continuing my mantra, I spent about 45 minutes walking around, photographing. I even climbed partway up the spiral staircase on the middle engine to take a photo of the third. Photo 2 shows the elegant staircase. Keep in mind that the stairs go up from the ground to the 3rd floor, and you can't see the entire engine in the picture!

For the most part, there weren't many people inside. Unfortunately, I didn't find a builders plate, so I have no idea of the lineage of these engines.

The tour groups eventually arrived. Since it was getting too crowded in the low-pressure building, I went out to get into the high-pressure building. This building is undergoing structural work, as one section of the back wall has collapsed out. Everyone in the tour was passed a hard hat. The number of hard hats was the limiting factor to the size of the tour. After a short wait, the tour started.

The high-pressure building contains three very different engines. One being the famous triple expansion Leavitt engine talked about at the meeting. There is a horizontal compound engine, and a triple expansion even larger than the ones in the low-pressure building.

As most of the people in the tour started to filter out, I started taking pictures again. Photos 3

and 4 show two different views of the Leavitt engine.



Chestnut Hill Photo 3

by Mike Boucher



Chestnut Hill Photo 4

by Mike Boucher

There are a few interesting things to note on this engine.

The first is all the magnificent lagging on the engine. I believe that is Walnut, and its gorgeous. If you look in the top right corner of photo 4, you can see the ceiling of the building in highlight. Note the woodwork on the ceiling. The whole building looks like that on the inside, all matching the woodwork of the Leavitt engine. They just don't make them like that anymore...

The second thing to note is that the flywheel is offset from the centerline of the cylinders. There is a large football shaped rocker. The connecting rod joins at one end of the football. At the top center (the laces of the football) is where the connecting rod to the flywheel crankshaft goes. The pivot point of this rocker is directly below the flywheel connection. The other end of the football is connected to the water pumps. See photo 5 for a picture of this rocker. (Once again, for a sense of scale, those are stairs in front.)



Chestnut Hill Photo 5 by Mike Boucher

As I was taking the photos, there was a mother there with two children in the 5-8 ranges. One child asked the tour guide if he could climb the stairs to look at the engine. The guide said yes. It didn't take me long to ask if I could, and I also got a yes answer. I crawled all over the engine. There is a myriad of walkways throughout the engine so the oiler and operators could do their work. See photo 6 for a view of some of the valving on the "third floor" of the Leavitt engine.

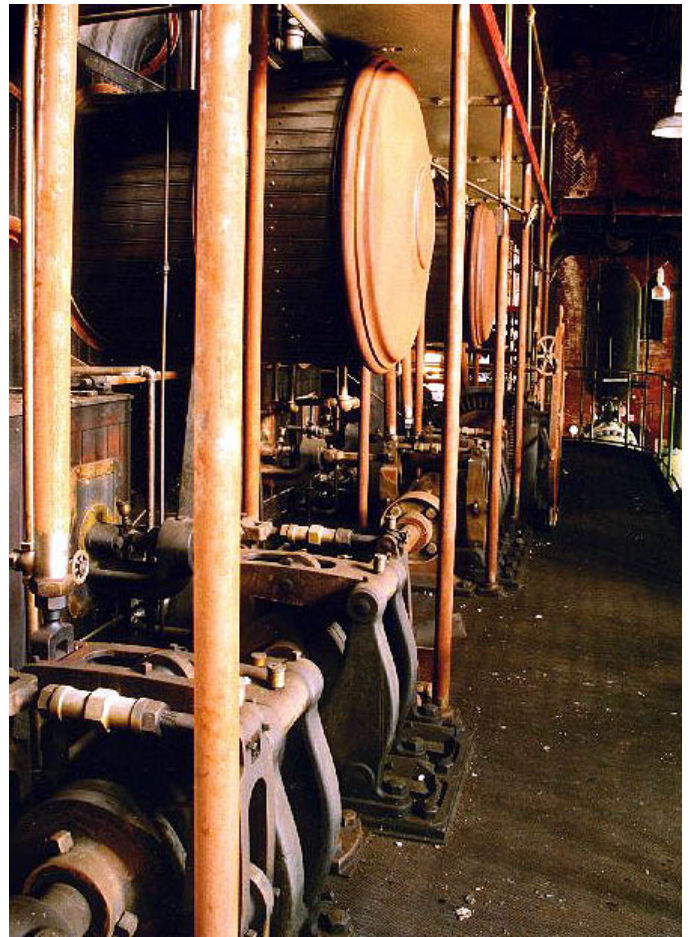

Chestnut Hill Photo 6 by Mike Boucher

While I was climbing on the Leavitt, another tour group came in. Included in the group were NEMES members Dick Koolish and Howard Gorin. Howard questioned who gave me permission to climb on the engine, to which I said, "He did!" as I pointed at the tour guide. This seemed to satisfy Howard.

The final stop on my inspection was the large triple. This engine, quite simply, was too large to capture in one photo. It's a massive machine. The builder's plate reads "The Howard F. Allis Company". Anyone know anything about this builder? My best attempt is captured in photo 7.

While at the 3rd level of the triple, I took a photo back across the building at the Leavitt engine. See photo 8 for this view.



Chestnut Hill Photo 7

by Mike Boucher



Chestnut Hill Photo 8

by Mike Boucher

The flywheel you see in the foreground is from the horizontal compound engine. I don't have any photos of that engine, as I ran out of both film

and time. I spent over an hour in the high-pressure building, and the open house was closing.

The story ends with both good and bad news. The restoration of the buildings into commercial space is going to mean that the three engines in the low-pressure engines have to be either dismantled and moved for preservation or destroyed. I fear the latter will happen, as I can't imagine actually moving the engines. The good news is that all three engines in the high-pressure building, including the only Leavitt engine left in the world, are all slated for preservation.

I hope to go back next year when the MWRA holds another open house.

Mike

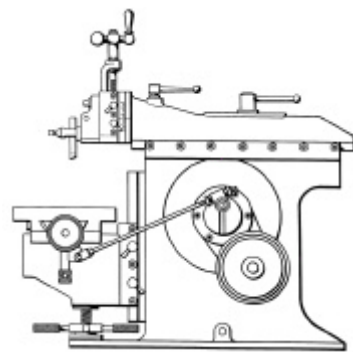

Metal Shapers

By Kay R. Fisher

Two months ago I posted a question about how to eliminate chatter when slotting on the shaper. I got some good feedback from Jay W. Stryker – our resident shaper expert who had this to say:

“The cure for chatter on the tool in a keyway is just spending time fiddling with it in terms of speeds and feeds and lube (if any) and the tool rake.

“I have had chips just peel off silently (like a wood plane) when I finally got the right speed and feed and rake - and I think I put a drop of some mixture of machinist's "snake oil" such as kerosene + cutting oil 50-50 or some such. A sharp tool is necessary, since you've got to think of the tool as a slow-moving chisel, with no “blasting through at high speed”. As with parting on a lathe, you might also do a small sideways set of cuts with an offset of 15 thou to provide clearance to the side if you have a straight-sided tool. A slight "VEE" on the top of

the tool would also work as a chip breaker or chip bender to drift them away from the sides of the cut. Old time shaper operators had "pet" tools for each job and kept them sharp - even touching them up with a pocket stone halfway through a job.

“Regarding the small sideways cuts. If you are doing a "plunge cut", the tool is the same width as the groove you want. This requires all the chips to be moved past the walls of the cut and out. In real life, a few chip bits want to jam between the tool side and the wall – galling, scoring, and perhaps chattering. The “VEE” profile idea is to make the chip a slight “V” so it is narrower - hence can escape. What I have used is not a true full-width plunge cut, but a series of slight sideways or zigzags as part of the down feed (shaper) or in feed (lathe) - if the chips do not come off the front in a nice curl. So for a 1/4-inch keyway use a 0.235 inch wide tool. Start your cut on center, go down perhaps 60 thou, or maybe to 100. Then shift sideways 5 thou for the next cut, then back the other way 10 thou for the next cut, etc. This gives 10 thou clearance for chips. A kind of rocking back and forth in the cut. You then have 5 thou left - call it 3 thou per side for trimming up the edges. It all depends on the material, lubricant, speed, feed and the machine rigidity.

“I found doing this with some of the CNC programs to make a plunge cut with a milling cutter also works. Sort of like the Panama Canal terraces in miniature. Then doing a final pass along the sideways surface to true it up. The cutter does deflect a little, so you end up with a slight slope in the wall unless you make a couple of passes.

“The shaper has chatter caused by alternate compression - release waves between the tool and the work making ripples and chatter. This is machine rigidity and “speeds and feeds” stuff. A minimal front rake, say 2 degrees acts as a "stop" for the sudden “in-plunge” of the tool since it actually rubs against the work. Of course, you then get some burnishing or work hardening. So too little front rake is not an optimal method but still might solve the chatter problem.

“Chatter big enough to see and feel is usually parts sliding up and down at the mechanical level.

Noise ("squealing") chatter is more the workpiece and tool vibrating (at a few kilohertz and up).

“The geometry of the "gooseneck" tool, where the cutting edge is behind the front surface of the clapper box, allows the tool to vibrate at much higher frequencies, resulting in a smoother surface. If you have a contact microphone with a good high-end range, you might put it on your shaper tool and get the frequencies.

“My own guess is that the gooseneck style has a slight lift-away to the back as it digs in, and the return speed is perhaps 10 times or more of the forward speed.

“This results in the tool actually traveling at, 400 feet per minute over the 3 thou of travel. So the tool is "buzzing" like an ultrasonic engraver. The old-timers "tuned" the tools by length and also clamping pressure, which I think shifted the frequencies. This was all “cut and try” stuff back then, but I suspect the tool-vibration issue is what helps to make some of those wonderful glass-smooth cuts a shaper is capable of.

“The empirical approach of the old-timers was such that the "master craftsman" had his little trade secrets, which thus made him more valuable to the company. A newcomer to the shaping department soon learned that it was not as simple as it looked and the old-timers would dole out a tip or "secret" one at a time to the individuals they liked and wished to stay in the department. The ones who didn't get the tips soon were fired or transferred.

“The ones who ran shapers in shops got their tooling "tuned" and optimized for the material at hand. The amateur who sets the work in the vise and selects a lathe tool and starts cutting is far from optimal. This leads to all the horror stories on how difficult it is to get a good cut with a shaper. It is machine, material and tool geometry specific. There is a learning curve for each cut.

“A part of the shaper operator's toolbox should be some samples of workpiece materials (scrap) to set up the tooling first and do a few trial cuts. That beats spoiling the one and only part, and in the case of the model engineer who has a casting from a defunct supplier, reduces anxiety. Always

do your shaper setting and tuning on a scrap bit of material first (or on a hidden portion of the actual workpiece).

“Recall, too, that the shaper speeds are low, almost off the bottom of some of the charts for speeds and feeds for HHS and Cobalt, etc. These are low speed, heavy feed environments. No place for carbides!

“I have often been discouraged with my shapers when I try this, and that, and then this, and then that - making scrap. However, once you do get the right combination, remember it and note it so you won't have to reinvent it the next time.

“Lindsay's South Bend book “How to run a Shaper and a Drill Press”... page 14 is figure 31A showing a roughing vertical cut with two or more finishing cuts (at presumably finer feeds)... the text is on page 21. What I was describing is the same idea with the vertical roughing cut. If chatter occurs - just cut the bottom on one side, then the other side as part of the roughing procedure and you could shift the table the 10 thou or more and do three or four down cuts, then shift it the other side and do a few more down cuts.

“Home Shop Machinist had a short article a few years ago on a massive shaper tool which was very stubby - like your thumbnail sticking out from a big clapper. It was reported to make a smooth cut.

“Shaper tool philosophy and design seems to go between the long slender tools to the short stubby ones. Each for a purpose and style of cutting.”

Thanks, Jay, for that great explanation.

Kay



Calendar of Events

By Bill Brackett

July 5, 2001 Thursday 7PM
NEMES Monthly club meeting, Waltham, MA
Charles River Museum of Industry (781) 893-5410

July 7-8 Boothbay RR
Boothbay, ME
Call: (207) 633-4727

July 8 Pepperell Show
Town Field Near Rotary on Rt. 111
Pepperell, MA
Kim Spalding (978) 433-5540

July 8 The Fabulous '50s & Sensational '60s Auto Meet
Owls Head Transportation Museum
Route 73 Owls Head, ME (207) 594-4418

July 15 Sunday 9AM
MIT flea market Albany and Main St. Boston MA

July 20-21 Sebago Days
Intersection RT 114 & 11, E. Sebago, ME
Ted Greene (207) 787-2424

July 14-15 Plymouth Notch Show
President Calvin Coolidge St. Historic Site VT
Bob Williams (802) 525-3931

July 21-22 Eastern Conn. Ant.Auto Show
Norwich Regional High School-Norwich, CT
Dick Babbit (860) 376-0863

July 20-22 Bangor Engine Show
Jacktown Community Center, Bangor, PA
Call: (610) 588-7466

July 21-22 Trucks, Tractors & Com Vehicles
Owls Head Transportation Museum
Route 73 Owls Head, ME (207) 594-4418

July 28-29 SubRegatta
U.S. Submarine Base, Groton CT
<http://www.subcommittee.com/>
Proof of insurance required getting on base

July 28-29 Eliot Tractor, Eliot, ME
David Raitt (207) 748-1046

Aug 2, 2001 Thursday 7PM
NEMES Monthly club meeting, Waltham, MA
Charles River Museum of Industry (781) 893-5410

Aug. 4-5 Scribner's Mill Show
Sebago-Long Lake Region Near Harrison, ME
Call (207) 583-6455

August 4-5 27th Annual Trans & Aerobatic Show
Owls Head Transportation Museum
Route 73 Owls Head, ME (207) 594-4418

Aug. 9-12 Pageant Of Steam
Canandaigua, NY:
Gary Love (716) 394-8102

Aug. 10-12 Cumberland Valley Show
Twin Bridges Campground, Chambersburg, PA
John Bricker (717) 263-5588

Aug 11-12 Conn River Museum Show
Steam Engine & Launch Show
67 Main St. Essex, CT (860) 526-5147

Aug. 11-12 Straw Hollow Show
Boylston, MA
J.A. Resseguie (508) 869-2089

Aug 15-18 Rough & Tumble
Kinzers, PA
Call (717) 442-4249

August 18 24 New England Auto Auction
Owls Head Transportation Museum
Route 73 Owls Head, ME (207) 594-4418

Aug 19 Sunday 9AM
MIT flea market Albany and Main St. Boston MA

Aug. 25-26 CT River Ant. Col. Club Show
Rt 5 At Old Ely Store, Ely, VT
Call: Douglas Driscoll (802) 333-3243

To add an event, please send a brief description, time, place and a contact person to call for further information to Bill Brackett at wbracket@ultranet.com or (508) 393-6290.

Bill



For Sale

Hermmes engraving pantograph

This is a large unit, about 3 ft square on the base. It has one full box of brass type in block letters, and some electrical symbols and Greek letters. It can do up to a 1:12 reduction. It came from the MIT hobby shop and seems little used. Its in fine condition, I just don't need (or have room for) this. \$100.

Ron Ginger (508) 877-8217

Misc Stuff

Set of 4 gears (54, 60, 72, 80 teeth); .540" bore, single keyway, 3-1/8 to 4-9/16 diam. **Free.**

Ellis Dividing Head, w/tail stock. Repainted, nice condition, all plates. \$110.

US Made Milling Vice w/swivel base, 4" jaws, indexed at 0 & 90 deg. Suitable for mill/drill or Bridgeport. Very nice condition, weighs approximately 30 lbs. \$55.

Palmgren 8" rotary table with X Y feeds. Clean repainted, some accessories, very nice shape. Professionally surface ground to assure base and table are parallel. Seen on the net for \$225 asking \$120.

Atlas Milling Attachment for 10 to 12 inch lathe, casting #10-502. Comes with MLA base casting for mounting on cross slide (if I can find it). Seen at shows for \$135. Asking \$120.

Sears (Lincoln) 180 Amp Arc Welder, with cables and manual. Also has a carbon arc torch. Works on 220V. \$110.

Howard Evers (508) 978-0654
email hwevers@charter.net

Web Sites of Interest

NEMES home page
<http://www.naisp.net/users/fisher/nemes.html>

MassCar Model Club
<http://www.masscar.com/>

This site claims it will be the definitive reference work on engine turning. Max ben-Aaron warns that it is fascinating, addictive and very time consuming.
<http://www.pledge.u-net.com/ref/images.htm>