

# The NEMES Gazette

Vol 4 No 47  
March, 2000  
© 2000

*The Newsletter of the New England Model Engineering Society,  
Stephen C. Lovely, Editor, POBox 277 Milford, Ma 01757-0277, 508-473-8621  
Ron Ginger, President, 17 Potter Road, Framingham, Ma 01701, ginger@acunet.net*

**Our Next Meeting is at 7:00 PM on Thursday  
March 2, 2000 at the Museum, 154 Moody Street,  
Waltham Ma.**

*Annual dues is \$20.00 - Please make checks payable to "NEMES" and  
send to the NEMES Treasurer: Kay R. Fisher 80 Fryeville Road  
Orange, MA 01364*

## This Months Contents

President's Corner .....	1
The January Meeting .....	3
Calendar of Events.....	2
Treasurer's Report.....	2
Shapers.....	3
Classifieds .....	8

## From the Editor's Desk:

I really enjoyed the talk on the Big Dig at the February meeting. I'd heard bits and pieces on it in the past, and seen incoherent news reports by people who didn't seem to have any idea what was going on. But I'd never seen a presentation on what was involved with the over-all project from someone who was familiar with it and enthused by it. I do have a question about the design life of 75 years for it though. The current elevated artery was completed in 1957. What was its design life? At about 40 years we started hearing we had to do something quick or it was going to start falling down. How long will the structures being built now last, and will they be paid for by the time they need to be replaced? I should add, however, that after seeing the presentation at the meeting I feel better about the whole Central Artery Big Dig Project than I ever have before.

This month we've got a new column starting in the Gazette. Kay Fisher has decided to write about shapers for the Gazette every month. I know I like my shaper, and I'm looking forward to reading what Kay has to say about them.

I won't be at the meeting next Thursday, but expect to be back for the April meeting. See you then, scl.

## The President's Corner by Ron Ginger

### March Meeting.

This is the long awaited Rudy Kouhoupt meeting. Several of us got to talk to Rudy at Cabin Fever and he has confirmed to me his speaking plan for our meeting. He will have some photos and talk about his own shop. He has also done some new models since his last meeting and will bring those and tell us about his latest plans. It should be a great evening.

The workshop session before the meeting was fully subscribed a while ago. I have sent a separate letter to all the people registered for that session with the details of time, place and payment. If you thought you were registered and did not get a letter call me as soon as you get this newsletter.

It would be a nice extra if anyone that has built a Rudy project were to bring it along to show before the meeting- we can set them on the tables in the big hall, and I'm sure Rudy would enjoy seeing them, as well as the rest of us!

### Cabin Fever Trip

We wound up with 36 people on the bus, a new record for our group. I believe we can safely say 'a good time was had by all' I don't want to rub it in to those that didn't make the trip, but this has become one of the best weekends I have each year. I did not get to buy my Henrob torch- the vendor didn't show up, but I found several other fine items. I think everyone else did as well, as the driver noted we were having trouble making some of the hills on the way home.

I am sure we will be making this trip again next year, so keep the date open- wouldn't it be great if we had to get TWO busses!

April meeting

As I noted last month we will focus on Electric vehicles for April. We will have at least one electric car that will be driven to the meeting and we will all get a chance to see it before the program starts. I have a nice article from Dave Robey on his electric vehicle work, and we will use that in next moths newsletter so you see it just before the meeting.

Newsletter

I am sure you all agree this newsletter is a major part of the success of our group. Steve has asked us to arrange some help with the copy editing and preperation. If anyone would like to help out with this we would surely appreciate it. Please contact me if ou can help.

Steam Class

George King III, the chief engineer of the Steamboat SABINO at Mystic Seaport has developed a 2 day hands on seminar on steam engines and boilers. George is clearly a master of this topic, and I think the session would be great fun. It is limited to just a few fellows, and George sent me a message that he has 4 openings for the next session, April 22-23. The cost is \$100 for both days. For more information contact George at gking3@mail2.nai.net. He can also be reached through Mystic Seaport Musuem.

--Ron

Calendar of Events

Mar 2, 2000 Thur 7PM

NEMES Monthly club meeting  
Waltham, Ma.  
Charles River Museum of Industry 617-893-5410

April 6, 2000 Thur 7PM

NEMES Monthly club meeting  
Waltham, Ma.  
Charles River Museum of Industry 617-893-5410

April 29-30

NAMES Show  
Wyandotte, Michigan  
Ron Ginger 508-877-8217

For a listing, please sent name and brief description of event, time and place and a person to call for further information to.

Bill Brackett at wbracket@ultranet.com or 508-393-6290

Feb 2000 Treasurers Report

Previous balance -----	\$4280.05
Cabin Fever Deposits -----	80.00
Ron Ginger Flowers &	
Address Labels -----	-73.48
Inn @ Reading (Bus Drivers Room)--	-146.52
Pat Fisher Cabin Fever exp & refund	-60.00
Cabin Fever Deposits -----	160.00
Withdrawal for Cabin Fever refunds	-620.00
Ron Ginger Flyer Printing -----	-44.89
Bob Neidorff (newsletter expense)--	-84.90
Dues Deposit -----	10.00
Service Charges -----	-4.50
Interest -----	.91
New balance -----	\$3496.67
=====	

The service charge this month is \$1.50 too much and I am getting another service charge reversal but won't see that in the account till next month.

The Cabin Fever bus trip worked out like this:

Bus cost-----	\$1985.00
Driver room-----	146.52
Driver tip-----	100.00
=====	
Total expenses	\$2231.51

Attendees paid \$60 each times 36 = \$2160.00 Difference equals \$71.51 it cost the club.

Originally I was expecting to make about \$20 but I transposed two numbers and thought our bus cost was \$1895 instead of \$1985. Ron spotted the error on the bus but I would rather give nice even refunds. I'll try and make up the \$71 on the trip next year for the club treasury. Remember there is an open request for someone else to become treasurer - please.

Respectfully  
Kay R. Fisher

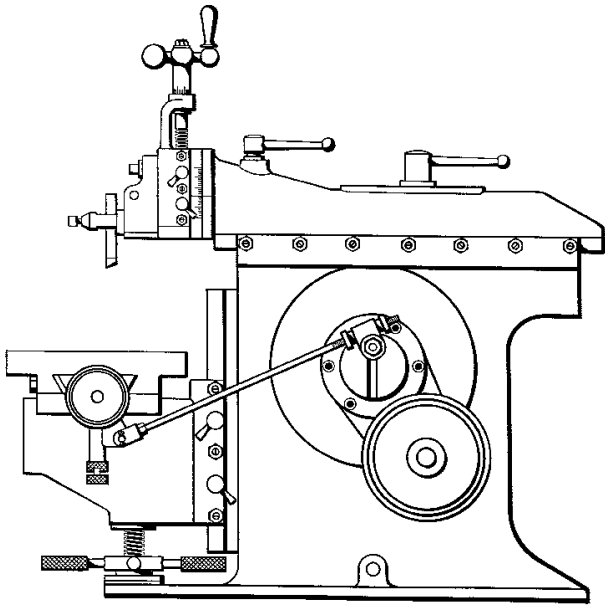

**Metal Shapers**  
by Kay R. Fisher

Welcome to the first shaper column. The reason for starting now is threefold. First as many of you already know, I have been working on a book about metal shapers. Over the next few months I expect to copy much of the book I've been working on into this column. Second, I recently volunteered to write the FAQ (Frequently Asked Questions) document on shapers for the rec.crafts.metalworking newsgroup on the World Wide Web. Third, the topic of shapers has come up so much recently at our club meetings that I think it is time to start a monthly column.

But before I start cutting and pasting, there is something you can do for me. I have been collecting Questions for the FAQ since I volunteered but guess what? There has only been one question so far and one implied question. So I would like you to write to me or send email with any of your shaper related questions. I'll take input anyway I can get it - verbal at our meetings, napkins with notes, glossy pictures, whatever.

If you own a shaper please let me know a little about it. Brand, size, weight, anything special about it, and best of all if you could - please

send pictures. If you have any anecdotal stories about shapers or any other shaper facts that you would like to share in this column (and in the book) please let me know. If you have a manual or any factory documentation for your shaper I would be interested in obtaining a copy but... Warning... Don't send any manuals without checking with me first - I may already have the one you're sending. If you send me something that you want returned (like a manual or picture) be sure to state that clearly. That said, I also am volunteering to be the keeper of shaper documentation so if you or anyone else needs a copy of something I have been able to obtain I will be glad to get a copy out.

Ok, now back to basics. Why am I writing a book about shapers? I'm not a shaper expert but when I obtained my first shaper I was disappointed at the available documentation. In the process of learning about shapers, I became sort of a shaper enthusiast. I've always wanted to write a book so I started. I'm kind of funny that way. Years ago I wanted to write a computer chess program - so I did. I didn't know a lot about chess and am still not a good player but I thought it was an interesting software challenge. It took a couple of years but I managed and learned a lot about programming games that require look-a-head tree searches, VAX macro, VMS, and book openings. Anyway, I don't claim to be an shaper guru but I do know how to do research.

My first task was to find and study all the existing shaper documentation I could get my hands on. After I did this I found that my first assumption (that there wasn't much documentation available for shapers) was wrong. But along the way I also found that there were many things that I could add to the existing literature. Not the least of which is the FAQ.

In the next monthly column I will publish a fairly comprehensive list of shaper documentation resources (the most frequently asked question). In future columns I will include the current outline of the book which hopefully you can help mold into something even more useful. After that I will get into the history of shapers and talk about why shapers are not dead.

Hopefully along the way with help from your letters and email I will answer some other questions and present some interesting shaper stories.

My mailing address is at the top of every newsletter (because I'm also the treasurer) and my email address is Kay.Fisher@Compaq.com

### **The Meeting, February 3, 2000**

This was the first meeting after the Cabin Fever Bus Trip, so we all expected to hear Ron tell us about his new Henrob Torch. We didn't though, because the Henrob guy wasn't at the show, although he had signed up for a vendors booth. We did bring a lot of other stuff back from the show though - the bus driver said he could tell the difference and had to shift down to keep up his speed on a couple of hills that he'd normally sail right up.

Howard Evers has visited Viet Nam recently and says that all the shops over there have big Chinese shapers made in the last five or ten years. He visited one new shop being set up with the latest CNC equipment. They also had two shapers. One set up for keyways and the other a 30" stroke machine for miscellaneous work. Don Strang pointed out that the reason old shapers are hard to find around here is that in the 70's a lot of them were exported to South America where they are still popular because labor is cheap.

Ron reported that he is now further ahead lining up programs for meetings than he has ever been. Rudy Kouhopt will be the speaker at the March meeting. He'll be hosting the workshop in the afternoon for about 20 people who signed up ahead of time for it and then will talk at the meeting. For April we'll have a talk on electric cars, with an electric being driven to the meeting. Then in May we'll have a talk on Moglice, the miracle bearing surface. An example that caught peoples fancy on the modelengineering email list was the case of the fish ladder. The fish ladder was provided to give fish a way around a large dam. There was an adjustment via lead screws and nuts to keep the ladder at the correct relationship to the water level above the dam. The bronze lead screw nuts were

wearing out in a very short time. Moglice nuts were made to replace the bronze nuts and they have lasted several years with no sign of any problems.

The main speaker for the night was Dan Wood. He used a computer with Corel Presentation software, which puts pictures and charts up on the screen via a projection monitor, sort of like a smart slide projector. So, he had a bunch of pictures and graphics that added to his talk but won't make it here into the NEMES Gazette.

Dan works for the Federal Highway Administration as a structural engineer. He's been with them for twelve years, the last 4 and a half here in Boston working on "THE BIG DIG" His job here is mainly focused on tunnels. He's been in transportation for his entire career and was focused on bridges mostly before coming here.

The project here in Boston involves building 8 miles of Interstate Highway, which is a total of 160 lane miles. The initial central artery was completed in 1957 as a major collector road. It was designed for 75000 vehicles a day and used no federal money. Today there are 190000 vehicles a day that travel on it. It has four times the national average accident rate, and there are 14 to 16 hours of gridlock on it each day.

Then he showed us a map of the major arteries into and through Boston. What it showed was 38 lanes of major highway merging into the 6 lanes of the Central Artery. The Central Artery is 1 3 / 4 miles long - with 27 on and off ramps in that distance. Sixty per cent of the traffic on the artery wants to go right through the city, but the on and off ramps slow it all down.

What will the project do? The Mass Pike will extend another two miles east to Logan Airport, completing Interstate 90 which will then run from coast to coast as originally planned. (Logan is the only Major Airport in the United States that is not connected to the Interstate Highway System.)

The Ted Williams Tunnel is open but there is no access to it other than from local streets. The Haul Road used by construction vehicles to avoid overloading the local streets during construction was an old railroad bed that had been

unused for years. It now has five separate types of bituminous pavement on it under test. The vehicles on it are of known load, and are counted.

The Ted Williams Tunnel was built using Immersed Tube Technology. The sections of the tunnel were built up from steel and brought to Boston by barge. Each section is 45 feet tall, 85 feet wide, and 325 feet long. One section a month was constructed and floated to the site of the tunnel. The road inside the tunnel is concrete, and was built in place within the steel sections. Each section has two parallel tubes, one for each direction. The flat roadway is part way up the cylinder, with the ceiling part way down. This leaves room for a large rectangular plenum both above and below the roadway. These plenums are used for forced ventilation, with air being pumped into the bottom plenum and out of the top one. All of the tunnels in the project have forced ventilation - some of the tunnels are up to 2 miles long.

The tunnel sections were removed from the barges they were floated in on and supported by pontoons. Bulkheads at the ends of each section kept the inside of the tunnels free of water and the inner construction was carried out. Each 325 foot long tube had a full size concrete truck in it for the construction. They stayed in the tubes till they could be driven out of the completed tunnel. With the sections floating from pontoons the inner structure was carefully built up in sections to keep the balance correct so the section would stay level and right side up. The completed sections would be carefully adjusted to 1 or 2 per cent from negative buoyancy, then when they were ready to be lowered they'd add water to tanks inside the tunnel sections to bring them about half a per cent negative buoyancy and they would be lowered into trenches dug into the harbor floor to receive them. The largest dredge in the world was used to dig the trench to hold the tunnel sections. The trench went 60 feet below the bottom of the Harbor Channel.

Global Positioning System sensors, lasers, and other instruments were used to make sure that the tunnel sections were located

where they were supposed to be. The position tolerance for the tunnel is 3 / 8s of an inch. When the sections of the tunnel are placed they are lined up with a 16 inch thick gasket in contact with the two sections. The water between the two bulkheads is then pumped out, which compresses the gaskets down to between 3 and 4 inches thick as the water pressure squeezes the two sections together.

There will be seven ventilation buildings when the project is finished, making it the largest mechanical ventilation system in the world. Twelve foot diameter squirrel cage fans will push fresh air in and draw exhaust out. For fires there is a plan on how to adjust the ventilation system to keep things as safe as possible. All the fans are reversible and the operators have manuals to tell them how to change the airflow. The idea is to keep the air moving in the direction of the traffic. For a big fire the trucks would go down the adjacent bore. Then hoses would be pulled through the connecting passages to fight the fire.

We are now in the middle of the peak construction period of the project - it is invoicing three million dollars a day to keep up the pace.

At this point he showed us some pictures of the artery from the south. The old road and the new road are in the same place. The alignment of the new artery and the old one are the same. Only two buildings needed to be taken for the entire project. As part of the project a \$4 million dollar bridge was built to allow shifting the traffic around so that the new, larger road structure can be built where the old road was. These temporary structures are modularized so that they can be reused as much as possible.

Work is being done to withstand category B seismic activity. This is better than the old artery was, but is not as robust as it would be for California, where things need to be able to deal with category C or D activity.

Segmental prestressed concrete sections are assembled with a gantry into larger post tensioned spans and put into place.

On most interstates the north and south sections run side by side. Here they don't always, because on of the prime directives of

the project is that the city cannot be shut down. Existing traffic flows have to be maintained. Construction needs to be done while the normal life of the city carries on around it.

The current raised Central Artery is going to be replaced by a tunnel. The way that this is being done is by cutting a slot and filling it with concrete down each side of the future tunnel. These slots serve five purposes.

1. They will be the wall of the tunnel.
2. They cut off water (which means they go down to bedrock - up to 140 feet in some places.)
3. They support the ongoing construction.
4. They support the surface street. What looks like a solid street from the top is often a cover over an enormous hole.
5. They support the existing Central Artery bridge, which is still carrying traffic although not necessarily still on it's original foundation.

These walls are known as "Slurry Walls" because of the way they are constructed. Since the area where the tunnels are going is mostly fill there is no way that you could dig a 42" wide trench up to 140 feet deep without some sort of shoring. Slurry is what is used to shore it up. As the trench is dug out the soil removed is replaced with a slurry that is heavier than water, and is higher in the trench than the water table. This keeps the trench open. Two types of machine are used for excavating the slurry wall trenches. One is a hydraulically operated clam-shell bucket. The other is the Hydromill. It has two large counter rotating cutters that grind up the spoil from the trench and pump it up to the surface where they filter the crud out of the slurry and put the cleaned slurry back into use.

Slurry wall techniques have been used for years in Europe, so as a result many of the personnel working on them here in Boston are from Europe because of the learning curve involved with the process.

The slurry walls can't be plain concrete, they need reinforcing. Soldier Piles are the answer. They are large steel sections that are bolted together vertically and lowered into the full depth trench a section at a time as they are

bolted together. They are located at 4 to 6 foot centers as required along the slurry wall. With the piles in place cement is pumped into the trench from the bottom, displacing the slurry upward where it is collected from the top for reuse.

With the slurry wall in place on both sides of the future tunnel excavation can begin. Temporary struts are used to span the space between the two slurry walls as the material between them is excavated to keep the pressure outside them from collapsing them inward. The excavation goes down to the bottom of the base slab for the tunnels. The base slab runs from slurry wall to slurry wall and can be up to 25 feet thick.

Once the excavation has gotten as far down as it is going to go they start at the bottom building up the tunnel. They try not to use tie downs to keep the tunnel down were is should be, because they can leak and cause problems. So, they use massive base slabs to provide the mass to keep the tunnel from moving up from buoyancy effects in the groundwater.

After they have built the tunnel up from the bottom to the top they still have a bunch of empty space above it. It will all be backfilled, but not with the stuff they took out when they dug the hole. The soils taken out will all go to Spectacle Island in Boston Harbor, which will be a park eventually.

When they get done with the Central Artery Tunnel there will be less on and off ramps than there were with the elevated artery. There will also be 4 traffic lanes and a fifth lane in each direction for acceleration and deceleration. The extra lane each way, combined with less on an off ramps will provide greater capacity for the new artery.

In front of South Station they are having to take out bedrock to get down 120 so that the road can go under the Red Line. The Red Line is the first subway built in the United States, and the tunnel is unreinforced concrete. So, the construction around it must be careful not to disturb it. The answer here is to use conventional underground mining techniques to build a bridge underground that will hold the existing Red Line

tunnel up over the new tunnel being built. Shafts will go down, then galleries will be tunneled out from them. Eventually the galleries will be filled with concrete and post tensioned using epoxy coated steel cables. (The epoxy coating is for corrosion resistance.) The concrete will contain flyash for increased durability. The steel wire will go into tubes which will be grouted to fill the holes after the wire has been stretched for the post tensioning.

There are 250 contracting companies involved in the Big Dig. About 12 are big companies that are the prime contractors.

Boston has been here for over 200 years, and all that time utilities have been putting pipes, conduits, wires, etc. into the ground. The first step in the process of digging a big trench through the middle of the city had to be getting the utilities that were in the way straightened up and organized so that the city could continue to have the utilities it needed. Over the years things had become chaotic. There were cases where a conduit was found that no one was willing to claim ownership of. So the only way to find out what is was was to cut it and see who complained about service going out. He showed us a map of the utilities before and after. Before was a real rat's nest. After actually looked organized. As a result of the utilities reorganization Boston now has all fiber optic cables and has the most modern telecom facilities of any city in the world.

To the north end of the tunnel will be the new cable stayed bridge. It will be the widest cable stayed bridge in the world when it is completed.

The Fort Point Channel is in an area that was filled with anything that they could find to build up the land. As a result the soil is particularly bad there. 600000 cubic yards of soil is being stabilized by adding cement through a soil mixing process. Since the rail traffic to South Station can't be interrupted and the tracks run over this especially bad soil the approach for the tunnel to go under the tracks is to freeze the soil to provide stability during the tunneling process. The ground is frozen. Then the pits for the ramps to the tunnel were dug. Forty foot high,

eighty foot wide tunnel sections were then cast in place in the pits. Each section is then jacked forward under the tracks until the tunnel is completed. The jacking is done with 52 500 ton hydraulic jacks. Eighteen inches is dug out of the frozen ground in front of the tunnel section and the jacks push it forward. Then another 18" is dug out and the push is repeated until the tunnel is all the way under the tracks.

During this entire process the ground stays frozen and the tracks 8 feet above the top of the tunnel are continuously monitored to insure that they are not disturbed.

The simplest way to get across the Fort Point Channel would have been to fill it in, but the EPA says it's a wetland so you can't. So it has to have a tunnel under it. The tunnel will be built using the immersed tube technique, but because of the low bridges in the way steel segments cannot be barged in as with the Ted Williams Tunnel and concrete tubes were cast on site. The first tube for the tunnel was floated into place in December 1999. There isn't room for pontoons to hold the concrete tubes up while they are being lowered into place, so they will be maneuvered into place while neutrally buoyant and then water will be added to them to lower them into position.

Cut and cover construction will be used to connect the Fort Point tunnel to the Ted Williams tunnel with a tunnel. There will be a section open to the sky where the current access ramps into the Ted Williams tunnel are. Only emergency vehicle access will be allowed at this open to the sky section, the current ramps will be gone.

At the airport end there will be all new ramps. Straight ahead out of the tunnel will go onto Route 1A.

When will it all be done? It comes in pieces. In October 99 the Storrow Drive bridge opened. In 2001 the extension of Interstate 90 to the Ted Williams tunnel will be open. Mid 2002 should see the Cable Bridge completed, with north bound traffic using the bridge then. In 2003 the bridge should open to south bound traffic. Then in 2004 it should all be done.

**Classified Ads:**

Seneca Falls Mfg Co #25 Metal Lathe - good restoration project for someone who would like to fix up an antique. It needs a good home. Stephen Lovely 508-473-8621

For Sale, Sears 10" Radial Arm Saw - older model on a stand, \$100. Sears 1/2 HP Compressor, \$50. Sears Dry Vacuum, Large, \$30. Clive Dalby, Andover, Mass. 978-475-5340

Brainard Horizontal Miller, Standard # 4 1 / 2 w/ MANY ARBORS & CUTTERS. Three quarters done over. 6.75 by 24 table, power feed off main spindle, flat belt drive. Size, 40" deep, 36 " wide, and 58" tall, weighs about 7-800 pounds. Has a small motor. \$300 OBO, need the space. Larry Micol, Waltham, 781-642-6637

*The NEMES Gazette*

newsletter of The New England Model Engineering Society  
c/o Stephen C. Lovely  
Post Office Box 277  
Milford, Ma. 01757-0277