



THE OPERATION AND CARE

OF THE

JACOBS

SPINDLE NOSE LATHE COLLET CHUCK

IMPORTANT!

Read the mounting and operating instructions carefully before using this chuck. The mounting suggestions will be especially helpful in securing all the accuracy that has been built into this fine tool. **SHORT PIECES** can be very successfully chucked if the instructions shown on page eight are closely followed.

SEE PAGE 8

SPINDLE MOUNTING SUGGESTIONS

AMERICAN STANDARD

CAMLOCK SPINDLES TYPE D-1

In order to secure the utmost accuracy provided by both the spindle and the chuck, it is suggested that the chuck be rotated around the face of the spindle and checked at each of the alternate mounting positions.

Precision Mounting

1. Make very certain that the spindle and the chuck mounting surfaces are free of grit and chips.
2. Place chuck in position on spindle and be certain that you can fit no more than a .004" feeler gauge between the front face of the spindle and the back face of the chuck.
3. Tighten the cams in the spindle with the wrench until they are bearing but not locked.
4. Make certain that the cams grip at a point between 90° and 180° of rotation. If any cam turns more than 180°, remove the set screw holding that particular stud and thread it into the chuck body one more revolution. If the cam grips before rotating 90°, remove chuck and back out that particular stud one revolution.
5. Tighten the cams to the locked position and indicate cone with .0001" indicator.
6. The desired accuracy should now be readily obtainable. A slight variation can sometimes be obtained by applying additional tightening to the cams axially in line with the high spot of the runout.

General Purpose Mounting

After selecting the most favorable mounting position by the precision method, this chuck can be quickly mounted repeatedly with assurance of accuracy.

1. Place chuck in selected position on spindle.
2. Tighten all the cams around the circumference of the spindle so that they are bearing but not locked.
3. Repeat tightening cycle locking the cams.

AMERICAN STANDARD

TAPER KEY DRIVE SPINDLES TYPE L

Precision Mounting

1. Turn lathe spindle so that key is facing up.
2. Make sure that the lathe spindle and the chuck taper are both free of grit and chips.
3. Place chuck in position on spindle and engage the draw nut thread.
4. Apply four or five solid hammer blows on a suitable spanner wrench engaged with the draw nut.
5. Indicate the chuck cone with an .0001" indicator.
6. Gently tap the draw nut with a babbitt hammer at a point axially in line with the high spot of the runout, as per drawing on page two.

SPINDLE MOUNTING SUGGESTIONS

TAPPING THE DRAW NUT

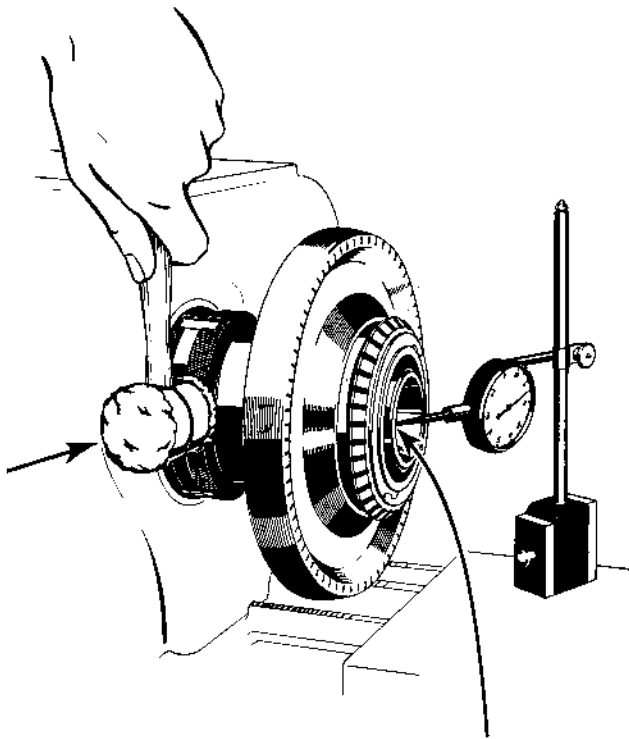

AMERICAN STANDARD SPINDLES TYPE A2

To mount model 91-A6 Chuck, it is necessary to remove the handwheel assembly to provide access to the spindle mounting screws. Instructions for this operation are found on page nine.

1. Make certain the spindle and the chuck mounting surfaces are free of grit and chips.
2. Place chuck in position on spindle and be certain that you can fit no more than a .004" feeler gauge between the front face of the spindle and the back face of the chuck.
3. Thread in mounting screws and then start tightening them gradually and evenly all the way around.
4. If the desired accuracy is not obtained, each of the possible mounting positions should be tried by rotating the chuck around the circumference of the spindle face.

7. Continue this process until the desired cone runout accuracy is obtained.

General Purpose Mounting

1. Follow steps one through four as described in previous procedure.
2. Rotate spindle 180°, engage spanner wrench, and give four or five solid hammer blows to spanner wrench handle.

THREADED MOUNTS

In order to secure the full accuracy of this chuck mounted on a threaded spindle, the adapter should be machined on the spindle itself by the user. The spindle acts as a gauge and assures accuracy of the final assembly of the adapter and chuck. Instructions for machining the adapter to fit the spindle and our chuck body are furnished with each chuck, and can be supplied upon request.

HOW TO OPERATE THE SPINDLE NOSE LATHE CHUCK

UNLOCK THE CHUCK

1

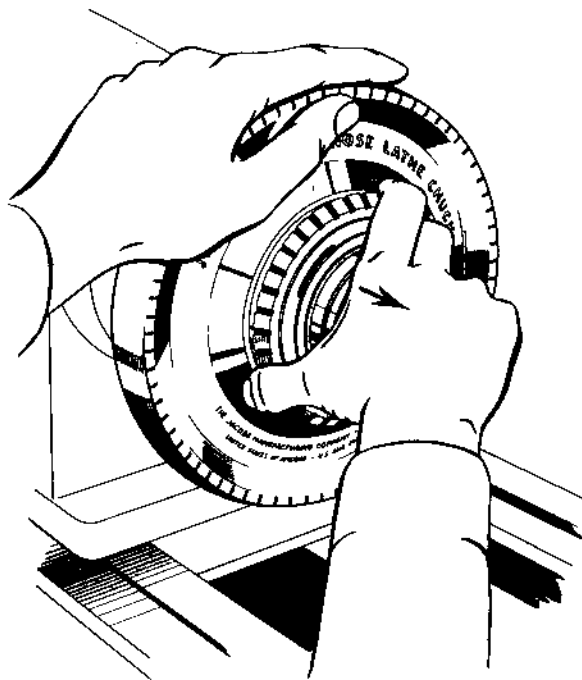

VIEW 1

Grasp the Lock Ring, and pull out away from the face of the Handwheel. The Lock Ring will slide out approximately $\frac{1}{8}$ " into the "Release Position."

REMOVE THE NOSE

2

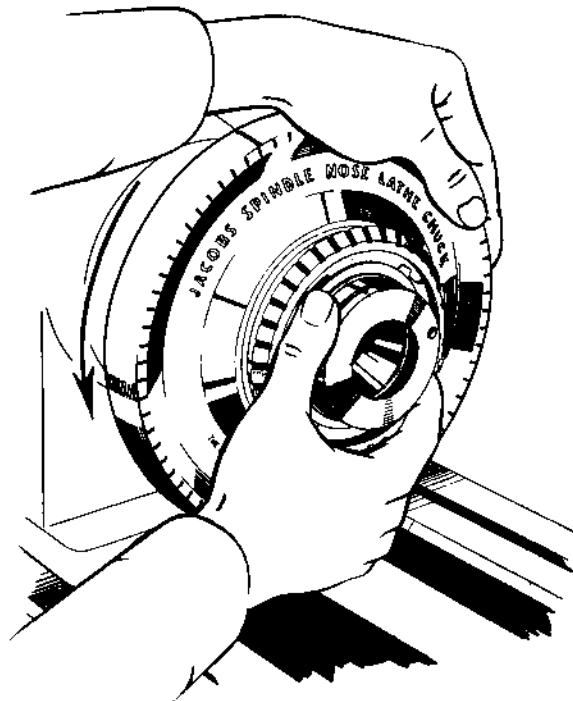

VIEW 2

Grasp the Nose lightly while rotating the Handwheel in the opening direction.

HOW TO OPERATE THE SPINDLE NOSE LATHE CHUCK

CLEAN THESE SURFACES 3

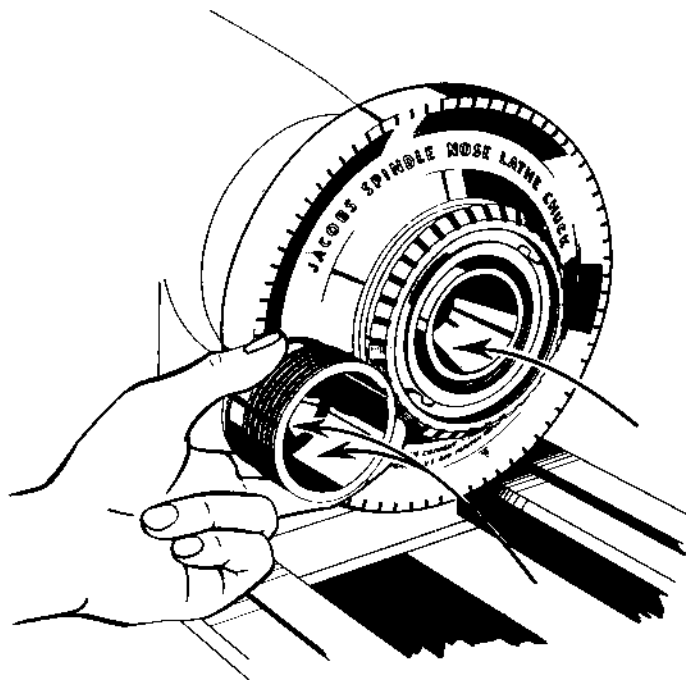

VIEW 3

To insure the great accuracy of this chuck, remove all dirt from the Body Cone and the inside of the Nose. Internal and external surfaces of the collet should also be cleaned.

INSERT THE COLLET 4

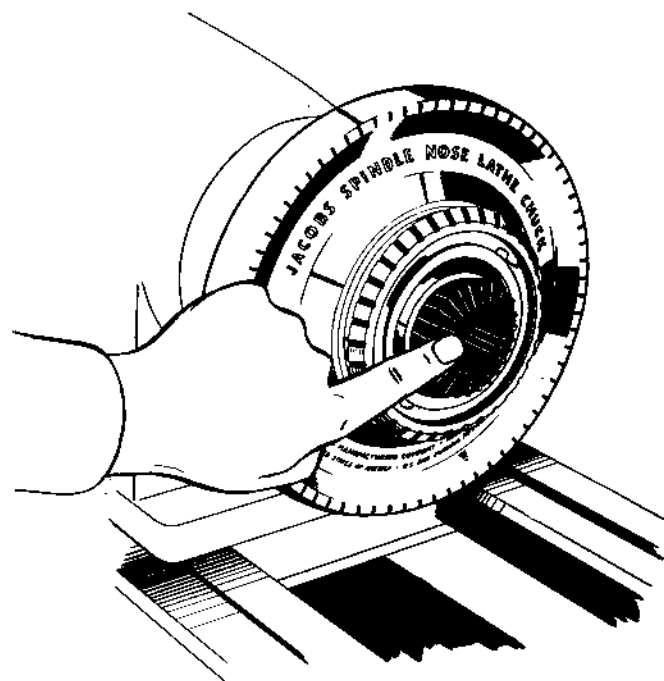

VIEW 4

Place the Rubber-Flex Collet in the Body Cone, and hold it in position with the forefinger of your left hand.

HOW TO OPERATE THE SPINDLE NOSE LATHE CHUCK

ASSEMBLE THE NOSE

5

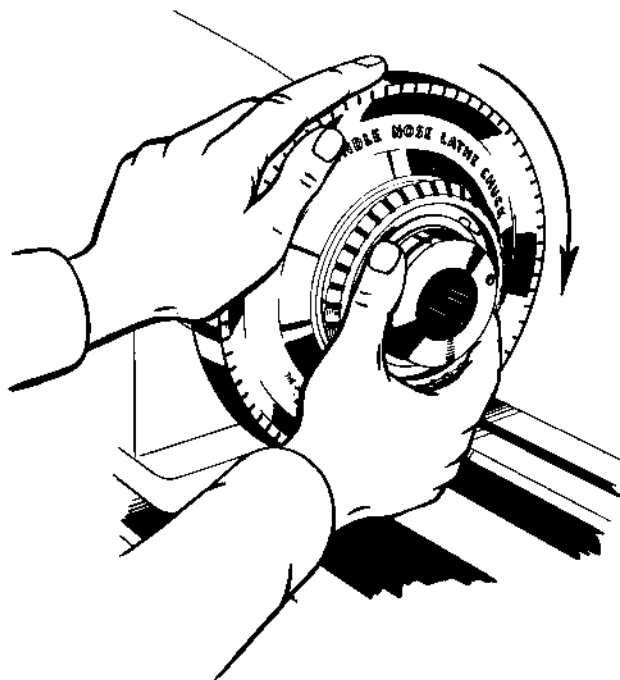

VIEW 5

Place the Nose in position over the Rubber-Flex Collet so that the keyway in the Nose is squarely opposite the Key. Note that the dot on the front face of the Nose is an aid in locating the keyway.

Thread the Nose into the chuck by rotating the Handwheel in the closing direction.

CLOSE THE CHUCK

6

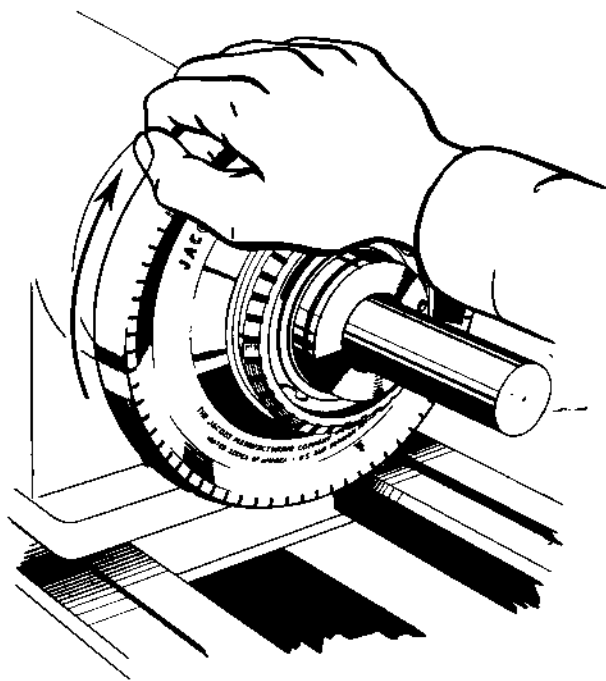

VIEW 6

Insert the work into the chuck and close the Rubber-Flex Collet Jaws by rotating the Handwheel in the closing direction.

WARNING

The bar being chucked must project at least $\frac{3}{4}$ " into the collet. For instructions on chucking Short Pieces see page eight.

IMPACT TIGHTEN THE CHUCK 7

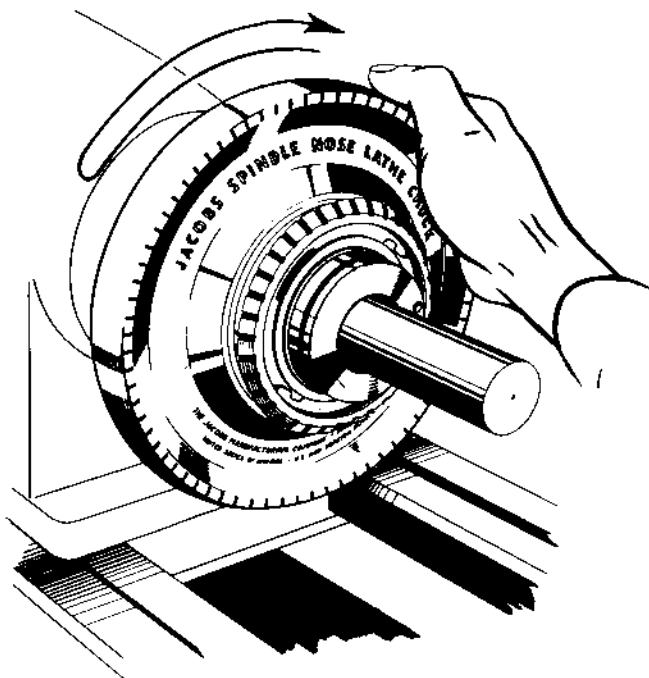

VIEW 7

Rotate the Handwheel in the *opening direction* approximately 90° to take advantage of the lost motion connection. Then, without releasing your grip, whirl the Handwheel in the *closing direction* against the internal stop mechanism. Repeat this operation so as to apply *at least three solid "hammer blows"*. Each "hammer blow" delivered by the Handwheel results in additional tightening.

When extreme gripping power is desired, as many as eight blows may be employed to secure maximum grip.

LOCK THE CHUCK 8

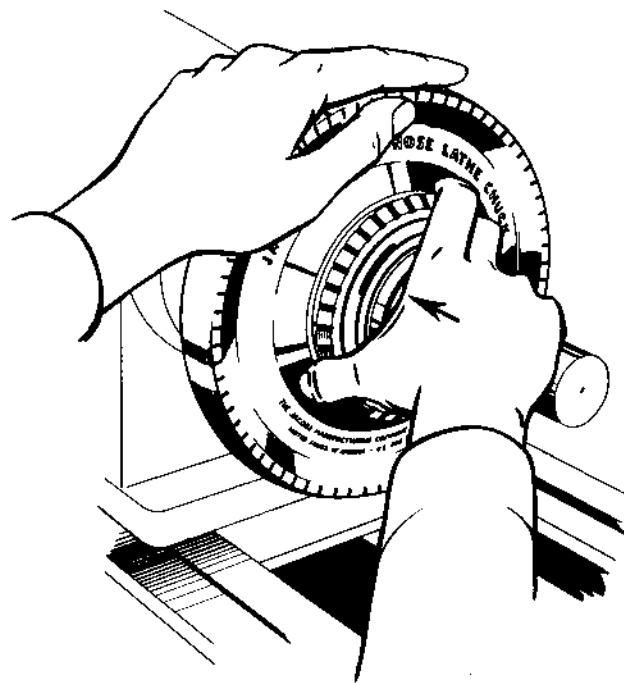

ALWAYS IMPACT TIGHTEN this chuck securely as this method of tightening will prevent collets from wearing out prematurely.

VIEW 8

Finally, press the Lock Ring in toward the face of the Handwheel while rotating the Handwheel slowly. The Lock Ring will slide easily into the "closed position" which positively locks the chuck handwheel to the body of the chuck. The Lock Pin seats in one of twelve Lock Pin holes in the Body spaced 30° apart.

HOW TO OPERATE THE SPINDLE NOSE LATHE CHUCK TO OPEN THE CHUCK AND REMOVE THE WORK

UNLOCK THE CHUCK

9

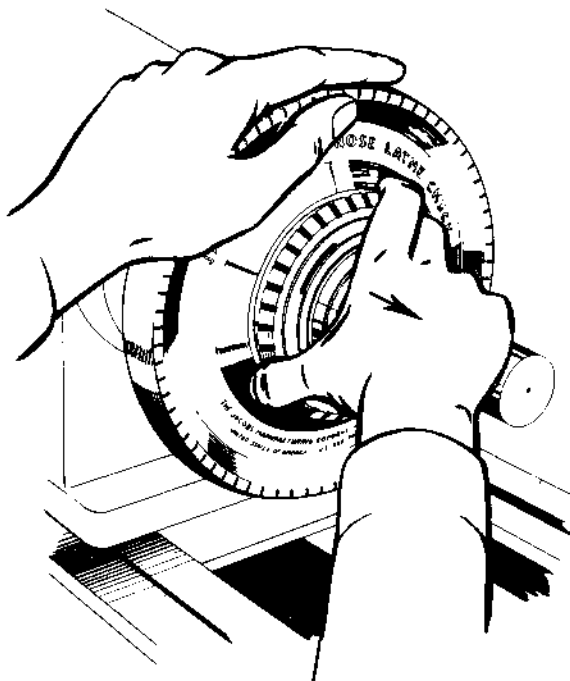

VIEW 9

Stop the lathe, and pull the Lock Ring out to the "Release Position".

IMPACT THE CHUCK OPEN

10

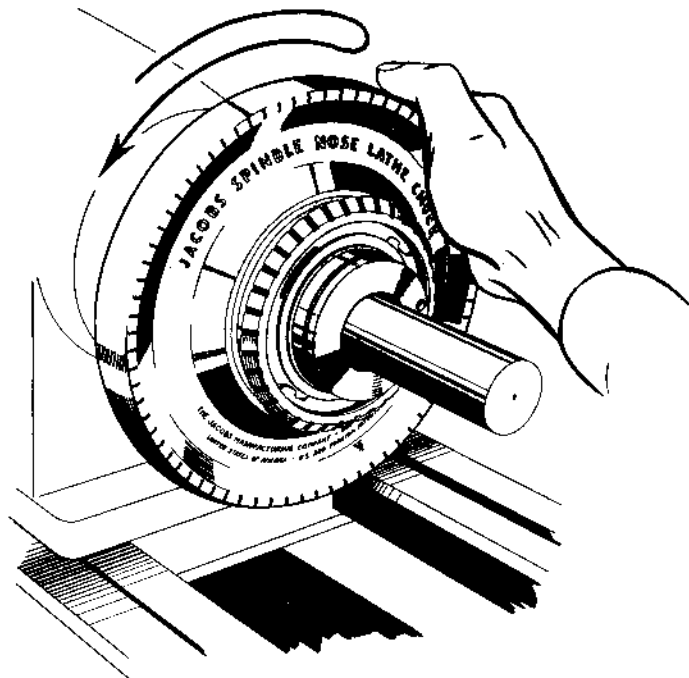

VIEW 10

Whirl the Handwheel in the opening direction against the internal stop mechanism, and apply as many "hammer blows" as necessary to open the chuck.

HOW TO OPERATE THE SPINDLE NOSE LATHE CHUCK

IMPORTANT — HOW TO CHUCK SHORT PIECES

INSERTING THE RUBBER COLLET 11 PLUG



When chucking short pieces that project into the Rubber-Flex Collet less than $\frac{3}{4}$ " , proceed as follows:

A. If the diameter of the short piece is the maximum capacity of one collet and the minimum capacity of another ($\frac{1}{8}$ " , $\frac{1}{4}$ " , $\frac{3}{8}$ " , $\frac{1}{2}$ " , $\frac{5}{8}$ " ,

1 " , $1\frac{1}{8}$ " or $1\frac{1}{4}$ "), select the largest capacity collet. Example: Select a $\frac{3}{4}$ "- $\frac{1}{8}$ " capacity collet for chucking a $\frac{3}{4}$ " diameter short piece.

- B. When chucking $\frac{1}{8}$ " to $\frac{1}{4}$ " diameter stock, care should be taken to use the J-911 Collet and not the J-910. The J-910 ($\frac{1}{16}$ " to $\frac{1}{8}$ ") is open sufficiently when at rest to permit the chucking of a $\frac{1}{4}$ " bar, but this collet is not designed to chuck a bar larger than $\frac{1}{8}$ " . To do so may cause damage to both the chuck and collet.
- C. There is a mating Jacobs Rubber Collet Plug, having a model number similar to the collet number, for all but the J-910 and J-911 Collets. Example: CP916 for Collet J-916. When chucking short pieces always insert the proper Jacobs Rubber Collet Plug into the back of the collet until the shoulder of the plug is firmly seated against the back of the jaws. See View 11. This plug is necessary in order to adequately support the rear part of the collet when chucking a short piece.
- D. An excellent substitute for the Rubber Collet Plug is a piece of stock turned to the same diameter as the short piece being chucked. When this is inserted in the collet it provides very strong support for the back part of the collet jaws.
- E. In chucking short pieces it is not necessary to excessively tighten the chuck. One or two light blows are sufficient.

DISASSEMBLY AND ASSEMBLY INSTRUCTIONS

To disassemble the Spindle Nose Lathe Chuck, follow the instructions listed below:

1. Rotate the Handwheel until the Nose is drawn all the way into the chuck.
2. Remove the chuck from the lathe, and place the chuck on its back on a flat surface.
3. Remove the Handwheel Retaining Ring by prying apart one set of the Retaining Ring Hooks with the blade of a screw driver.
4. Lift the Lock Ring off over the Nose, and remove the Washer and the Lock Pin.
5. Lift the Handwheel Assembly off the Body by holding the Nose down with your thumbs while raising the Handwheel Assembly with the fingers of both hands.
6. Rest the chuck Body on its side with the Ball Bearing Loading Hole in the Impact Sleeve pointing up. Insert the points of two scribers into the two holes of the Disc Retaining Ring in the Loading Hole; and by pressing the ends of the Disc Retaining Ring together, remove this ring from its groove in the Loading Hole and then remove the Loading Hole Disc.
7. Hold the chuck in mid air with the Ball Bearing Loading Hole pointing down over a small container suitable for catching the Ball Bearings when they drop out. Hold the Impact Sleeve firmly in your right hand, and rotate the Body slowly until all thirty-three $\frac{1}{4}$ " Ball Bearings have been removed.
8. Rest the chuck on its back and lift the Nose and Sleeve Assembly off the Body.
9. Unscrew the Nose from the Impact Sleeve.

To assemble the Spindle Nose Lathe Chuck, follow the instructions listed below:

1. After thoroughly cleaning and oiling their mating threads, thread the Nose into the Impact Sleeve.
2. Place the Nose and Sleeve Assembly over the Body Cone so that the Nose Keyway is opposite the Body Key, and lower the Nose and Sleeve Assembly into place.
3. Hold the chuck body on its side with the Ball Bearing Loading Hole in the Impact Sleeve pointing up. Load all thirty-three $\frac{1}{4}$ " Ball Bearings through the Loading Hole. Do not crowd an additional ball into the race as it will cause the mechanism to stick.
4. Oil the Ball Race with a good grade of light machine oil through the Loading Hole.
5. Insert the Loading Hole Disc into the Loading Hole with the small plug projection pointing out.
6. Press the Disc Retaining Ring into the Loading Hole until it expands into its groove in the wall of the Loading Hole.
7. Apply a good grade of light machine oil to the inside diameter of the Handwheel Assembly.
8. With the chuck resting on its back, lower the Handwheel into position over the Nose.
9. Insert the Lock Pin into the T Slot of the Lock Ring.
10. Insert the Lock Pin into the Lock Pin Hole in the Handwheel, and press the Lock Ring down into position.
11. Place the Washer in its groove in the Lock Ring.
12. Place the two halves of the Handwheel Retaining Ring on the front face of the Lock Ring and around the Impact Sleeve. Engage one set of hooks, and force the second set of hooks to lock by pressing the two halves of the Retaining Ring together.

IMPORTANT

To insure long life and best results from the Spindle
Nose Lathe Collet Chuck, note carefully these instructions

1. Be sure that the nose is assembled in the chuck whenever the lathe spindle is rotated. As the Handwheel depends upon the Nose for a large part of its bearing surface, damage to the Ball Bearing Race will result if this precaution is not followed.
2. Always impact tighten this chuck as this method of tightening will prevent collets from wearing out prematurely.
3. It is best not to leave a collet compressed in the chuck when not in use.
4. Do not chuck tapered pieces.
5. When working with hot-rolled stock, tighten the chuck by delivering *no less than six "hammer blows"* with the Handwheel.

CARE OF THE SPINDLE NOSE LATHE COLLET CHUCK

1. Keep the chuck and collets clean.
2. Keep the threads of the Impact Sleeve and the Nose clean and well lubricated at all times.
3. While not in use, keep collets in their moisture proof box to prevent rusting.
4. Keep the Ball Race and the inside diameter of the Handwheel well lubricated at all times (See Assembly Instructions — Steps four and seven on page nine.)
5. To obtain maximum collet life keep them clean and do not store them in direct sunlight.

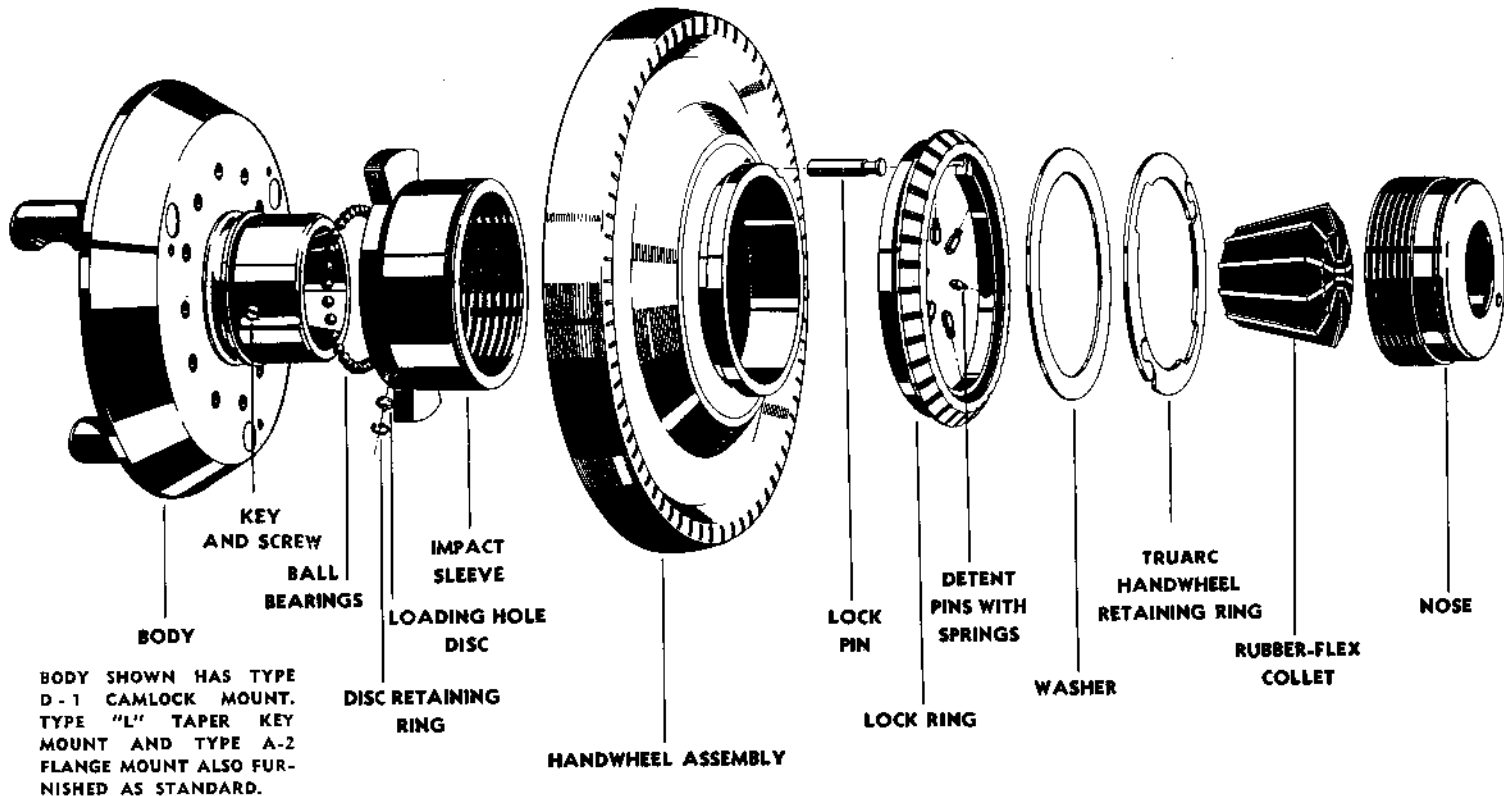

The Jacobs Spindle Nose Lathe Chuck and Rubber-Flex Collets are protected by the following United States and Foreign Patents:

<i>United States</i>		<i>German</i>	<i>Canadian</i>
2,346,706	2,459,899	829,397	Patented
2,346,707	2,459,900	845,890	1946, 1947,
2,584,303	2,536,519	859,400	1951
	2,508,731		
	D161,552		
<i>British</i>	<i>French</i>	<i>Brazilian</i>	
584,258	Brevete S.C.D.G.	31,959	
617,964	912,726		
672,006			
<i>Japanese</i>	<i>Belgian</i>	<i>Swedish</i>	<i>Austrian</i>
200,194	506,293	125,251	186,947