

Taper Turning with stationary component by WOHLHAUPTER Facing and Boring Heads UPA4...UPA6 s7

a.) Combination of axial and radial feeds and depth adjustment

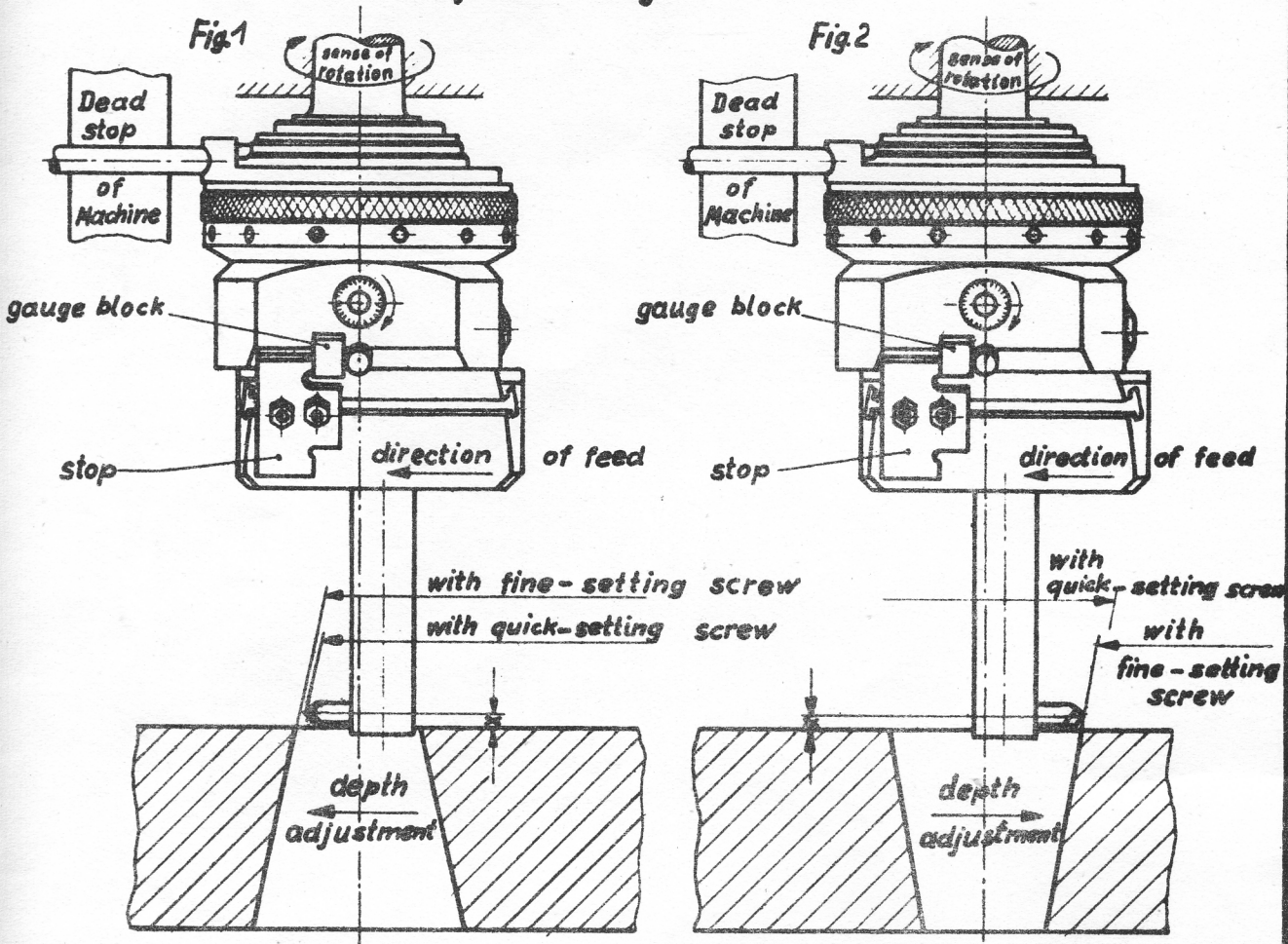

b.) Height adjustment of cutting tool

