

DESCRIPTION OF WORK-HOLDING DEVICES

Unit 1-T52(B) Pages 97 to 116

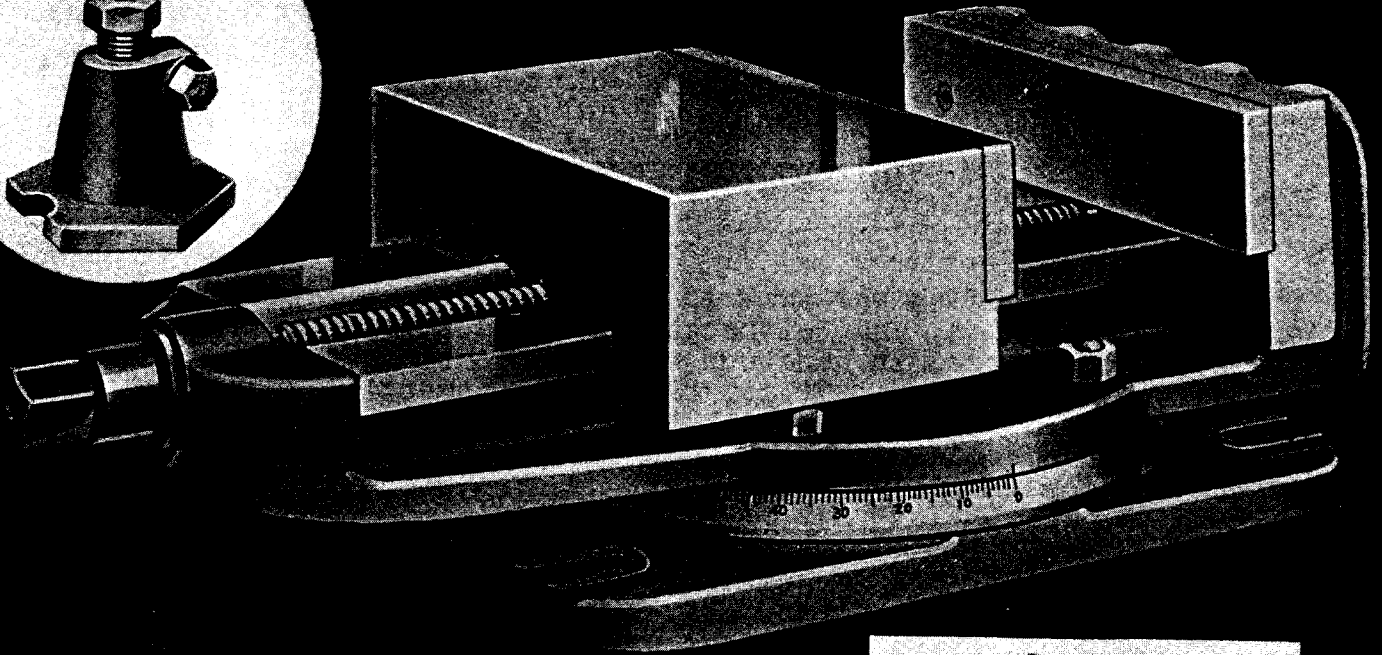
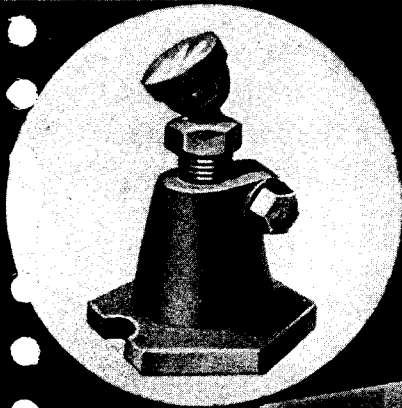
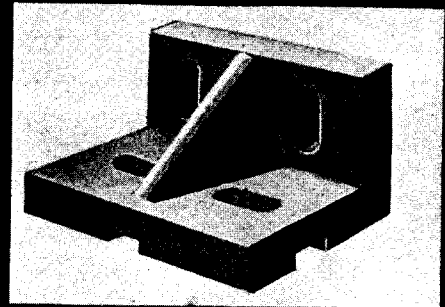

Photo by courtesy of Western Machine Tool Works



UNIVERSITY OF THE STATE OF NEW YORK
STATE EDUCATION DEPARTMENT
BUREAU OF INDUSTRIAL AND TECHNICAL EDUCATION

DESCRIPTION *of* WORK HOLDING DEVICES

OBJECTIVES OF UNIT

1. To describe the principal types of shaper vises.
2. To describe other types of holding devices.
3. To discuss some of the reasons, advantages, and disadvantages for the selection of the type of holding device.

INTRODUCTORY INFORMATION

The manner of holding the work in the shaper is an important part of shaper operation, and, although the devices used are simple, they can be arranged in numerous ways and combined to accommodate a wide variety of work. It is, therefore, essential that the shaper operator be familiar with the different types of holding devices and be acquainted with some of their particular features so that he can intelligently select the most suitable method of holding the work.

Most of the small work is held in the shaper vise which is bolted to the top of the work table. If, however, the work is too large or for any other reason cannot be held in the vise, the vise can be removed and the work secured to the top or, in some instances, to the side of the table.

Ordinarily, the shaper table is large enough to support the whole area of the work, but there are times when large pieces that extend beyond the shaper table can be conveniently machined if the overhanging portion is given additional support. The limiting factors for this procedure are the length of the stroke, the ability of the tool to reach the surface to be finished, and the advisability of using the shaper for the work to be machined.

Sometimes, what appears to be a very complex setup can be made comparatively simple by using a holding device called a fixture, and, although fixture design is beyond the scope of this manual, nevertheless, simple arrangements of standard holding devices combining the methods of holding work as set down in this section, are not beyond the ability of the intelligent shaper operator to suggest or even to design.

DESCRIPTION OF WORK-HOLDING DEVICES

THE SHAPER VISE

The principal parts of the vise are the base, the body, the fixed jaw, the movable jaw, the screw, the handle (or wrench), and the plates which are attached to the face of the jaws.

The bases of the vises (Figs. 89, 91, and 92) are bolted to the table by either three or four bolts, the number of bolts depending upon the design of the base. The base is graduated through an arc of 180° with a zero (0) position on the left side, a zero (0) position on the right side, and with a 90° mark in the front, midway between the two zero marks. On the underside of the base are provided square keys which fit into the table slots and which square the base on the shaper table.

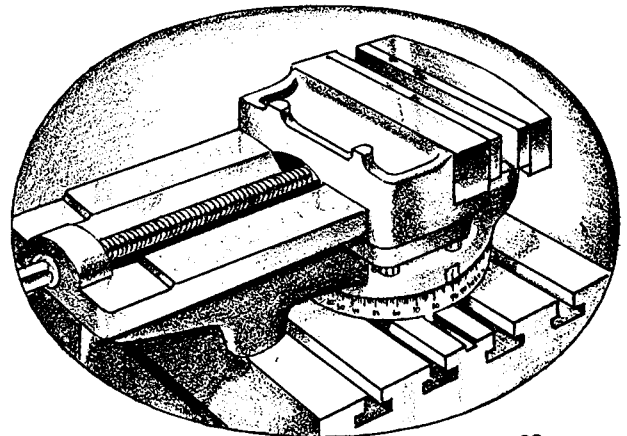

FIG. 88

The body of the vise is a semisteel casting which fits on the base of the vise (Fig. 89). The heads of the bolts, which are free to slide, are held in a circular groove in the underside of the body. When the vise is being assembled, the bolts pass through holes in the base and holes in the table as shown in Fig. 90. Washers and nuts are placed on the bolts which extend into the openings and, when tightened, secure the vise and base to the table. When the nuts have been loosened, the vise can be swiveled to form any angle with the direction of the stroke. The pilot in the base provides a central point about which the body of the vise swivels.

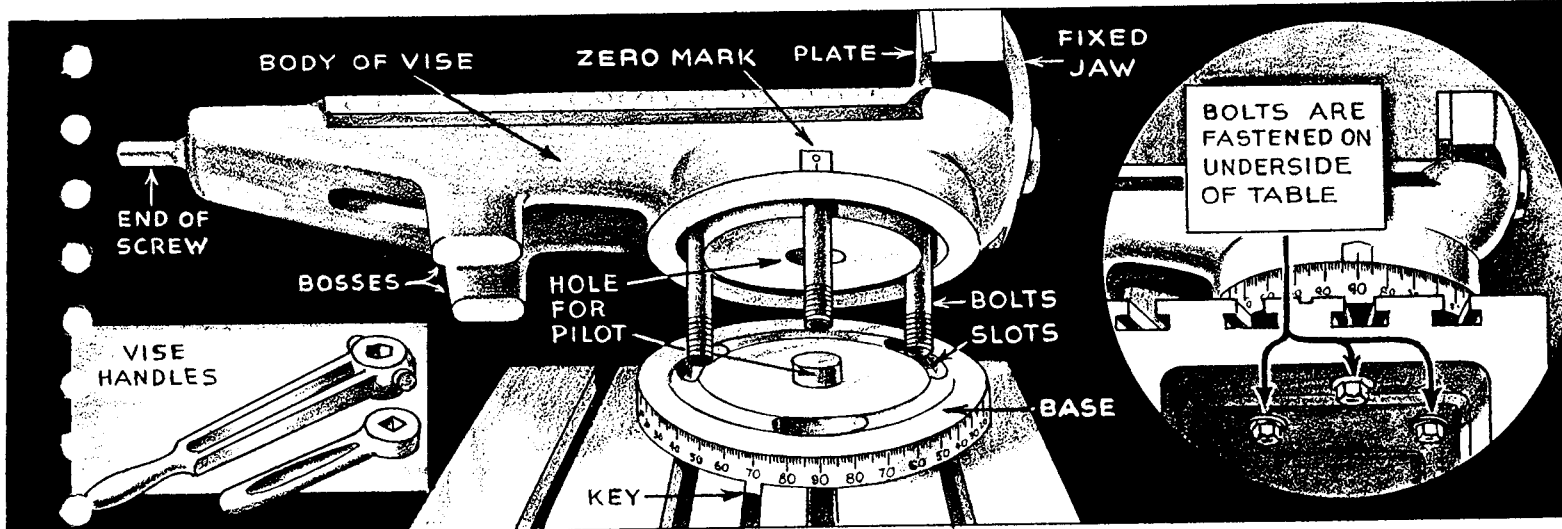

FIG. 89

FIG. 90

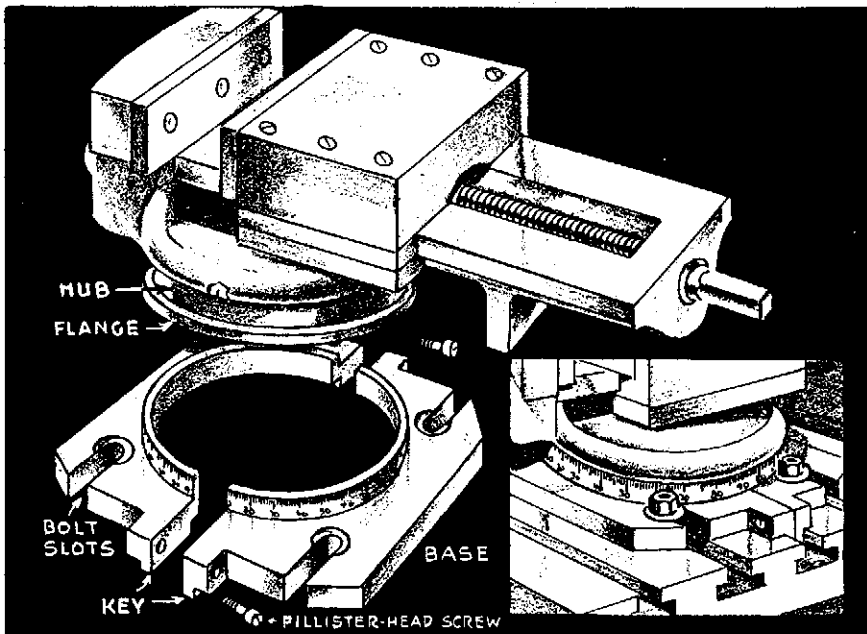

FIG. 91

In the design shown in Fig. 91, the base acts as a clamping ring for the body. It is split so that it can be assembled on the projection called the hub (Fig. 91) on the underside of the body of the vise. Two fillister-head screws hold together the two halves of the clamping ring, or base. The vise may be swiveled to any angle horizontally and, consequently, when the nuts which hold the base to the table are tightened, they exert a downward pull on the flange of the hub and hold the vise securely in position.

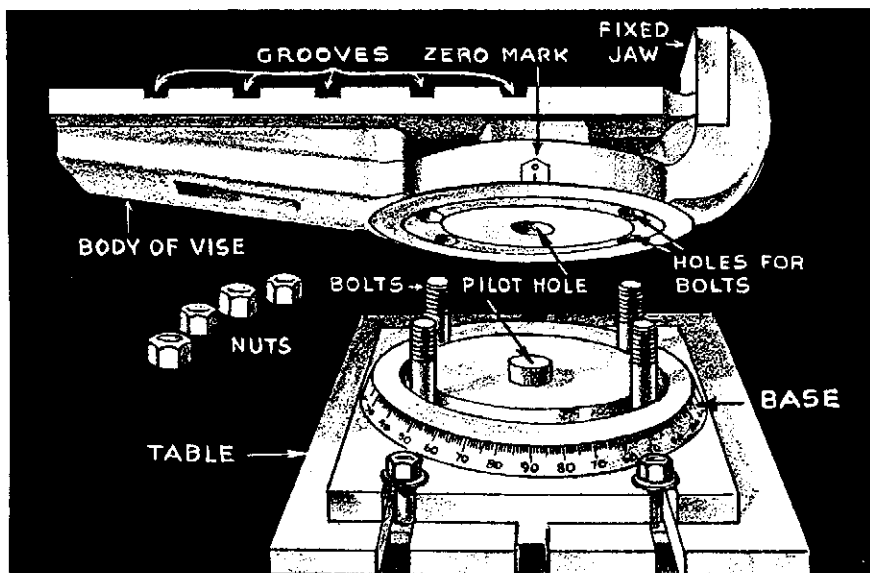

FIG. 92

The base illustrated in Fig. 92 is bolted to the table of the shaper and is held independently of the vise body (Fig. 92). The base is made with a circular T-slot to receive the heads of four T-bolts. The bolts project above the base and are made long enough to pass through the flange on the bottom of the vise and to hold a washer and a nut. When the nuts are loosened, the vise may be swiveled horizontally to any desired angle. The vise is securely clamped to the base when the nuts are tightened (Fig. 93).

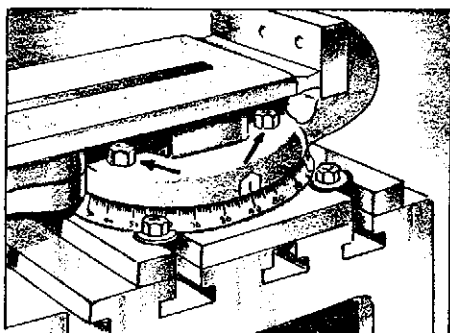

FIG. 93

The vise (Fig. 89) has bosses which are cast on the underside of the vise body. The bosses provide additional support when wide pieces are held between the jaws or when the vise is used with the jaws at right angles (90°) to the direction of the cut. When the vise is in this position and the work is held vertically, the jaws should be offset to permit the ends of

bars to be machined (Fig. 94).

The solid, or fixed jaw, (Fig. 96) is an integral part of the vise body and is machined square with the surfaces upon which slides the movable jaw (Figs. 95 and 96). Both the fixed and the movable jaws are usually faced with either annealed or hardened and ground steel plates. Although hardened and ground plates hold their accuracy better and their surfaces are not so easily damaged, annealed plates have a slightly greater gripping power. The plates may be removed by taking out the screws which attach them to the jaws. This becomes necessary only if the plates need to be reground or machined.

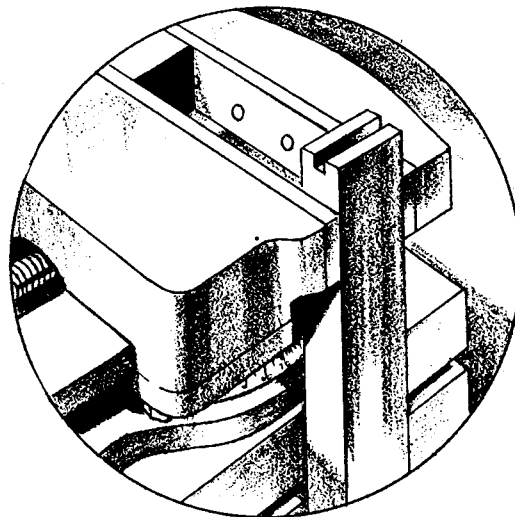
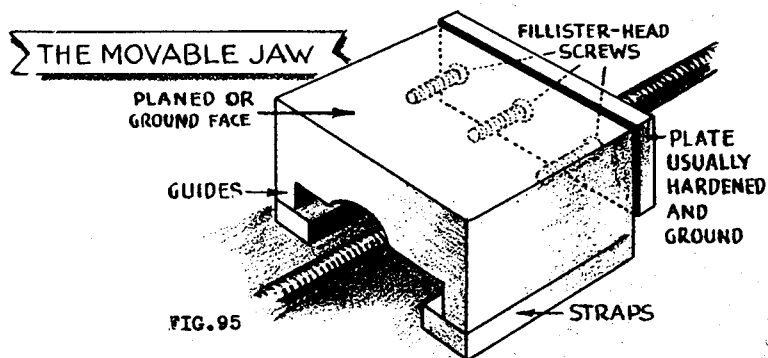

FIG. 94

Movable vise jaws are operated by either single or double screws. The movable jaw (Fig. 95) is operated by a single screw and is provided with guides to hold it square. The straps are bolted to the underside of the block and are adjusted to allow the movable jaw to slide without the tendency to lift excessively.



The vise screw passes through a nut which is attached to the bottom of the movable jaw; two bearings, one at each end of the casting, support the screw (Fig. 96). A large washer is placed on one end of the screw to receive the pull caused by the tension on the screw when the vise has been tightened. The lock nuts or adjustable collars hold the washer in place and provide for necessary adjustment. The movable jaw of the single-screw vise has a flat top which

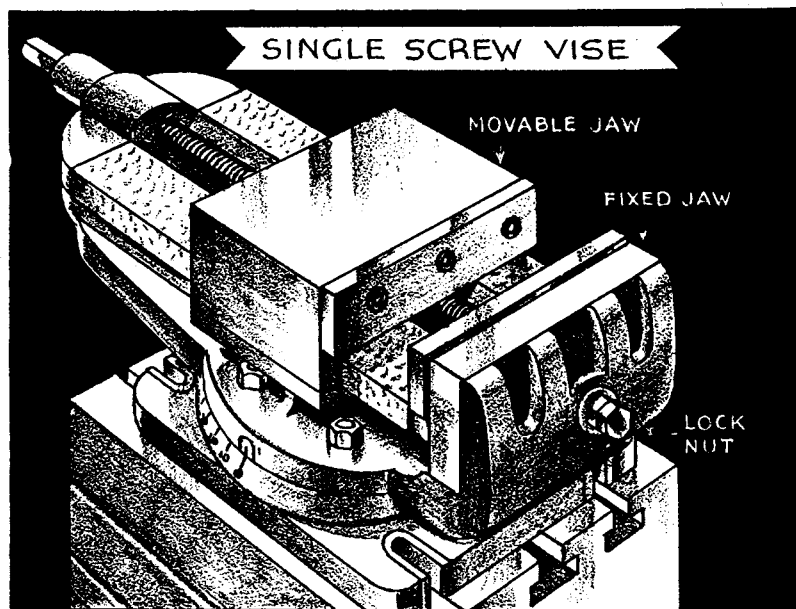

FIG. 96

may be used as a surface plate for use with measuring instruments.

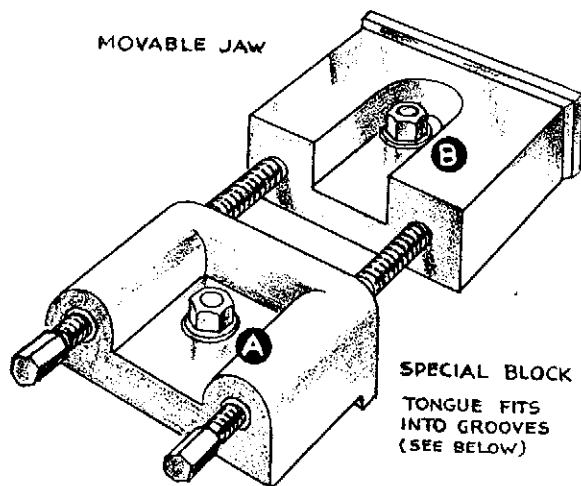

FIG. 97

A vise also may be equipped with double screws (Fig. 97). The movable jaw of this vise is made without guides and, in addition to holding straight work, it will hold work with a slight taper. When the nut B has been loosened, the movable jaw can be moved forward by hand until it is against the work. The jaw is forced against the object by two setup screws which are held in a special block and which can be adjusted to suit the position of the movable jaw. When the nut A (Fig. 98) has been loosened, the special block may be raised so that the tongue on the underside may be lifted clear of the groove. The block may then be moved to any position in which the tongue and groove coincide and in which the adjustment is enough to allow the screws, when turned, to force the movable jaw against the work. When the nut A has been tightened, pressure can be applied to the movable jaw by tightening the two setup screws. Finally, the nut B must be tightened to hold the movable jaw firmly against the surface of the vise body.

to allow the screws, when turned, to force the movable jaw against the work. When the nut A has been tightened, pressure can be applied to the movable jaw by tightening the two setup screws. Finally, the nut B must be tightened to hold the movable jaw firmly against the surface of the vise body.

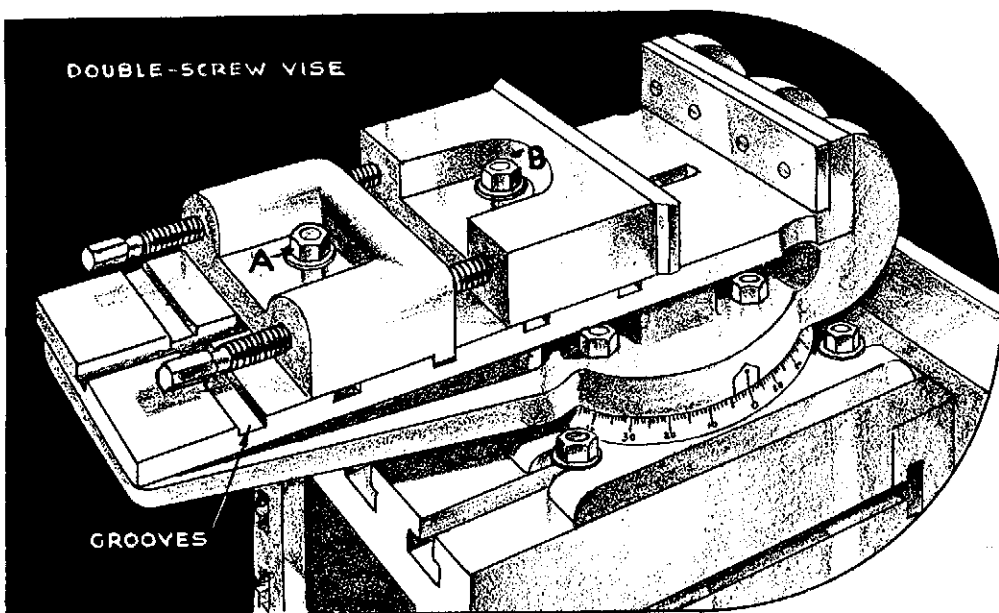
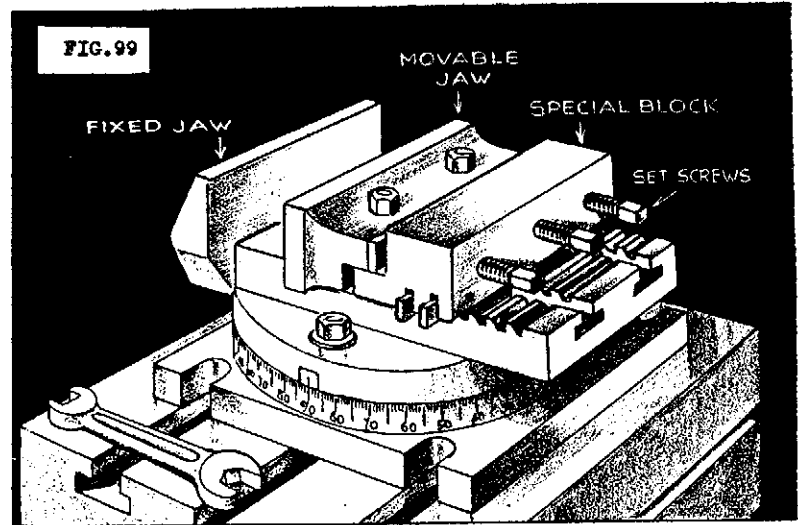

FIG. 98

The shaper and planer vise illustrated in Fig. 99 is frequently found in machine shops. The vise embodies the same principle as the double-screw vise, but the special block which holds the set screws is furnished with two plates in-

stead of the tongue and groove used in the previous design (Fig. 98). In addition, the block has a ledge upon which rests the undercut surface of the movable jaw. Three smaller set screws take the place of the two heavier screws with which double-screw vises are equipped. The jaws of this vise are not faced with steel plates.



The selection of either the single- or double-screw vise will depend upon the nature of the work. The preference for the single-screw vise is based upon the fact that the single-screw type is simpler and quicker to operate; on the other hand, the double-screw vise has the advantage of being able to hold work with a slight taper and to hold the movable jaw very securely against the work.

For tapered and irregularly shaped pieces, a vise (Fig. 100) with a swiveling movable jaw may be used. The jaw is pivoted on a central stud which allows the jaw to align itself against the side of the object. Two bolts are used to clamp the jaw in position. It should be observed that the screw draws the swiveling jaw to the work instead of forcing the jaw forward. Whenever the vise is to be used to hold regularly shaped pieces with parallel sides, the swiveling jaw must be set in line with the fixed jaw. This is accomplished by using a dowel pin which is provided for locating the swiveling jaw in proper alignment with the fixed jaw.

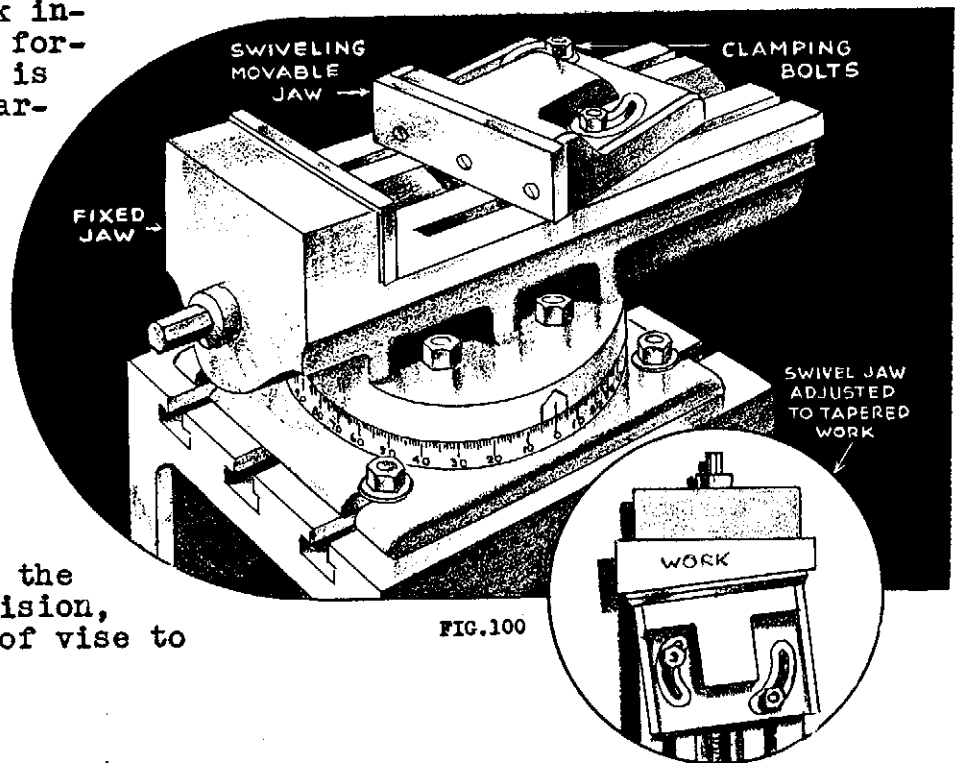

Manufacturers of shapers supply a vise as part of the regular equipment of the machine, leaving the decision, however, as to the type of vise to the purchaser.

PARALLELS

It is not always practicable to place the work between the jaws of the vise or to lay the work directly on the table without some supporting piece underneath. Sometimes projections on the underside of the work require that the piece be raised to clear the projections, or it may be necessary to raise the work a definite amount, or otherwise to simplify the machining operations. These supporting pieces are called parallels (Fig. 101). They are square or rectangular bars A made in pairs of either cast iron or steel. Frequently parallels are made by cutting off two pieces from a square or rectangular bar of cold drawn steel, or they may be accurately machined to any desired size. For general shaper work, the larger parallels are often made of cast iron and have grooves cut the entire length of their surfaces as shown at B. The purpose of this is to lighten the parallels somewhat and present less area to be cleaned and to be kept free of burrs. Another method of lightening parallels is to undercut the sides and cut holes in the webs as illustrated at C. When extreme accuracy is required, the parallels are made of steel which is hardened, seasoned, and ground.

There is no definite standard as to how high, wide, or long a parallel must be. Opinions vary as to what are the most suitable sizes to have available for use with the shaper. Manufacturers usually sell parallels in sets which are designed so that when used singly or in combinations they will give a wide range of sizes. For general shaper work, parallels should range progressively from about 1/8" high, 1/4" wide, and 6" long, up to about 3" high, 1-1/2" wide, and 12" long. To suit special purposes, however, it is often more economical and more practicable to make or purchase a set of parallels instead of using available parallels in combination.

Occasionally, adjustable parallels D very conveniently can be used to support the work in the shaper vise. As the parallels can be set and locked to micrometer measurement, any height from 3/8" to 2-1/4" can be obtained with a set of these parallels.

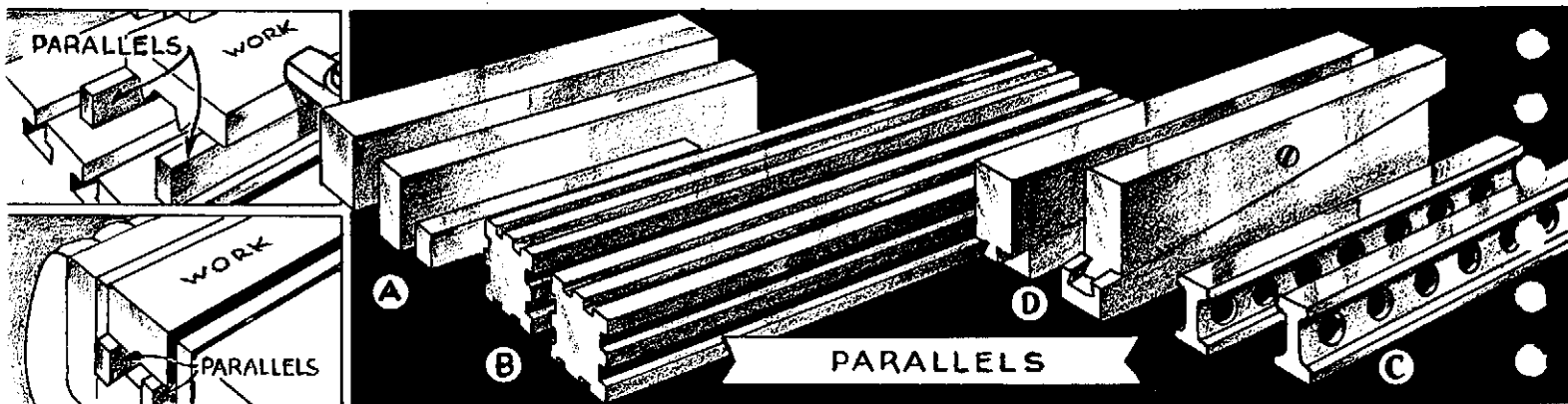

FIG. 101

SHAPER BOLTS

The most convenient method of fastening work or work-holding devices to the table is by the use of T-head bolts. For holding vises and many other types of work and work-holding devices, the square T-head bolt (Fig. 102) is ordinarily used. The heads of these bolts fit into T-slots which are cut in the shaper table. The square T-head bolts must be inserted in the end of the slot and moved along lengthwise to the desired position. The bolts cannot turn in the slot or be lifted out of the slot, which, of course, is the purpose of the square head and the T-slot.

For use with some setups, it is more convenient to place the bolt in the slot after the work has been placed on the table. For this reason, a cut-away T-bolt (Fig. 102) is manufactured. This bolt can be inserted into the slot and then turned. The head is made narrow enough so that it can be placed in the top of the slot, and, as the length is longer than the width, a partial turn of the bolt causes the head to catch on the side of the T-slot and thus prevents the head from further turning. Besides, the head catches on the underside of the slot and prevents the bolts from being pulled out.

For types of work in which different lengths of bolts are required, the tapped T-head bolt (Fig. 102) is frequently used. The head, or block, is tapped to receive a stud which may be made to any desired length and on which a thread is cut on both ends. The head of the bolt can be inserted into the T-slot and moved along to the assigned position. The stud is then screwed into the head as far as the shoulder of the thread will permit. The shoulder will prevent further turning of the stud in the head when the nut is being tightened. The assembled bolt, likewise, is held in the slot by the head. A nut and a washer are furnished with each bolt.

Bolts, alone, are limited in their use to objects that have holes or slots to receive them. Used with clamps, however, bolts may be utilized for innumerable purposes.

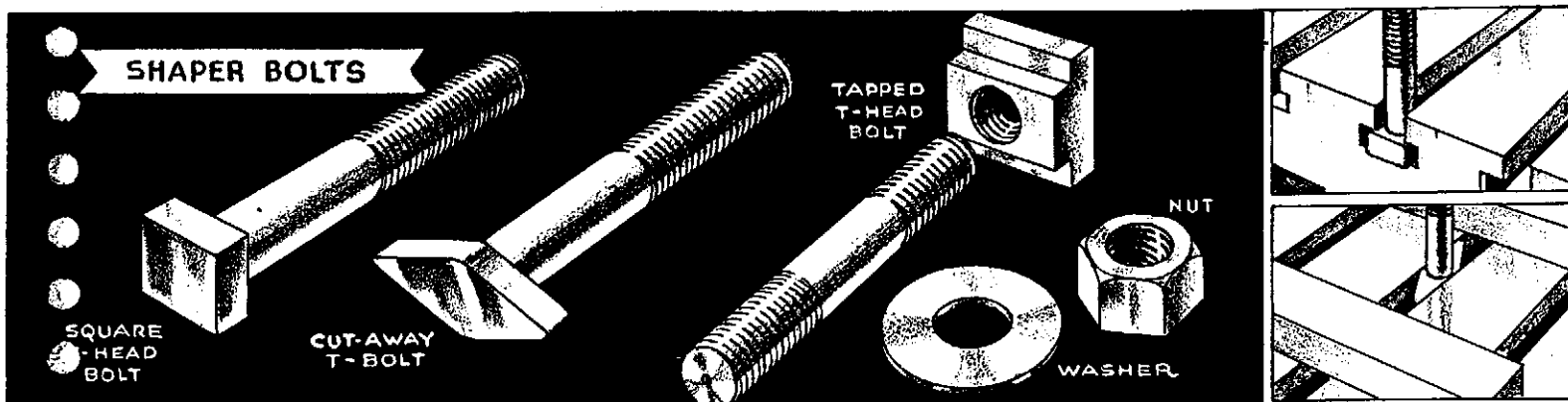

FIG. 102

STRAPS OR CLAMPS

Clamps are designed to hold objects which have a wide range of sizes and shapes. Usually the styles purchased from the manufacturers are sufficient for most purposes, but there are occasions when special ones must be made. As clamps are subject to severe usage, they should be made of tough, heat-treated steel.

The plain clamp, illustrated in Fig. 103, is stiff and strong and is used for general clamping purposes. It is made with an elongated slot, or hole, through which the T-bolt passes. The bottom of the clamp is flat; the top and the sides taper. The shape of the work to be clamped must be such that the clamps can be placed in a position which will not interfere with the machining of the surfaces.

An exceedingly useful clamp is the U-clamp (Fig. 104) which is made with a continuous slot, and is open at one end. The U-clamp has an advantage over the plain clamp which has a closed slot, because it can be removed without taking the nut off the T-bolt, and the bolt can be located in the most advantageous position for clamping by pushing it along the slot in the clamp. The disadvantage of the U-clamp is that it has a tendency to spread and bend under heavy clamping pressure. The U-clamp may be purchased with or without a finger, but although the finger adds to the usefulness of the clamp, it is better to use the latter type (Fig. 105) whenever this type can be employed.

When a finger clamp is used, the finger is usually supported in a drilled or cored hole in the work. This is a convenient method of holding the work without interfering with the machining operations. Drilled holes, however, may be objectionable, and, unless a cored hole is available, another type of clamp must be used.

Duplicate pieces with cored or drilled holes in their sides can be held with a

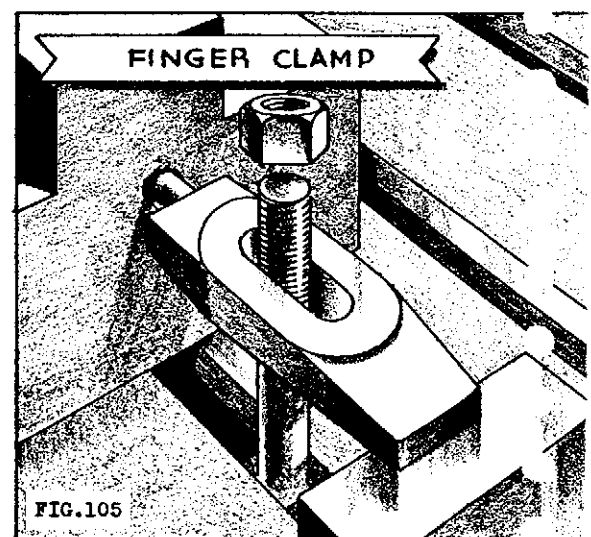
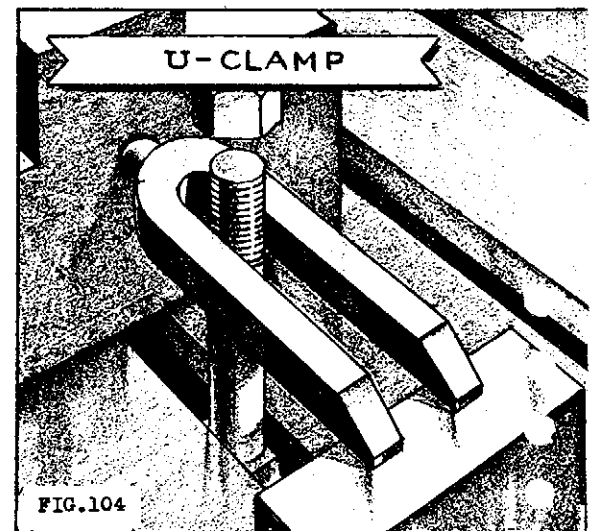
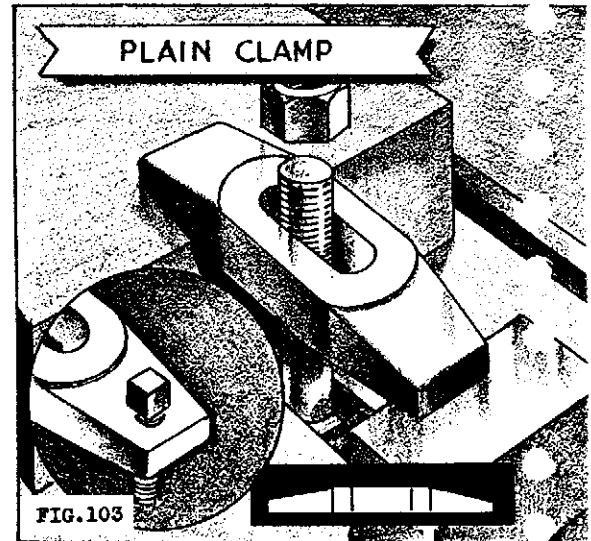

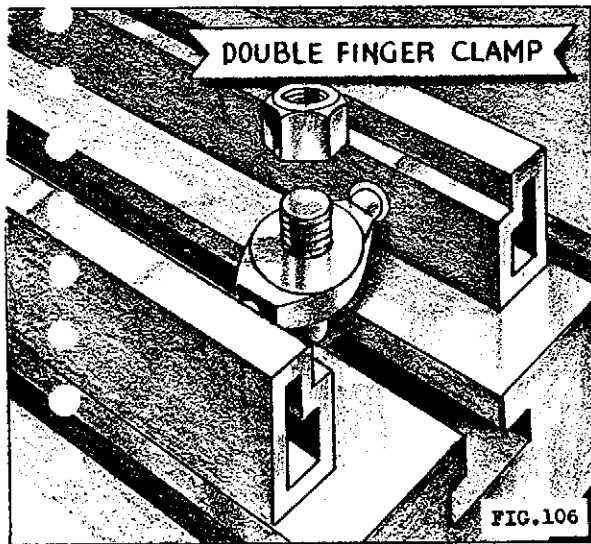

double finger clamp illustrated in Fig. 106. As the double finger clamp is a little shorter than the usual style of clamp, the work can be placed so that one bolt will clamp the two pieces.

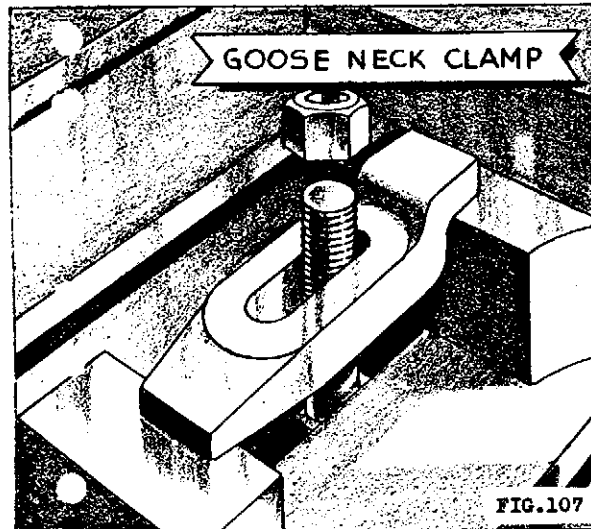

A gooseneck, or offset clamp is shown in Fig. 107. The offset feature of this clamp allows the top of the clamping bolt and the nut to be below the surface to be planed.

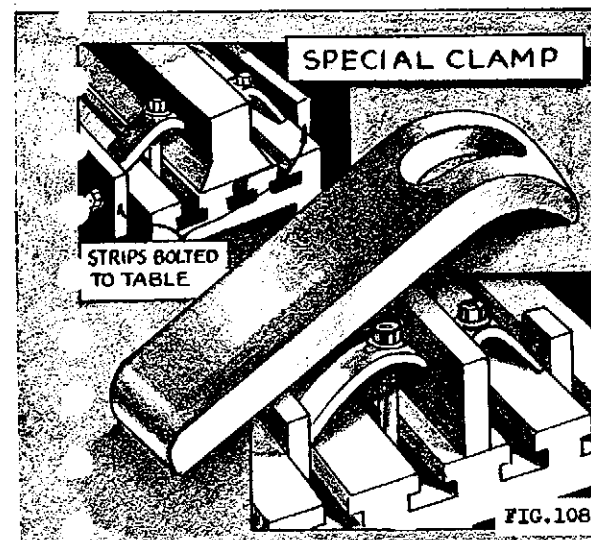

The adjustable clamp shown in the insert (Fig. 103) is similar to the plain clamp, except that the adjustable clamp has a set screw in a tapped hole opposite the clamping end. This adjustable device allows the back of the clamp to be raised or lowered by turning the screw to the right or to the left. By this means the clamp may be quickly adjusted to the height of the clamped surface without the use of packing strips. The single-point contact of the screw may or may not be an advantage. If the part to be clamped has a curved surface, there will be a tendency for the clamp to slide off the work. In contrast, if the clamped surface were flat but set at an angle causing the clamp to be tilted slightly sideways, then the single-point contact of the screw would be an advantage. The final decision, as to whether an adjustable clamp or a plain clamp is to be used, must be left to the judgment of the individual.

The clamps previously described are usually adequate for most clamping purposes, but occasionally a special clamp is preferable, such as the one illustrated in Fig. 108. The clamps are placed between stops inserted in the table slots and the work to be clamped. When the nuts on the bolts are tightened, the work is forced downward on the table. It should be noticed that four slots in the table are required for this setup; whereas most shaper tables are provided with three slots. This deficiency can be overcome, however, if a strip is clamped on both sides of the table and allowed to project above the top of the table about one inch in order to take the thrust of the clamps. (See Fig. 108.)

STOPS

Stop pins (Fig. 109) are used to prevent movement of the work on the table. They can be placed at the ends or along the sides of the work in order to take the thrust of the tool, or they can be used to hold the work to the table. For locating the stops in relation to the work, the table is provided with holes in addition to the T-slots. Plain stops, as shown at A, may be round or square pieces of steel turned down at one end to fit the table slots or the reamed holes in the table. Often stop pins are plain blocks, B, which can be inserted into the table slots, or they may have holes drilled or slots cut through the center so that they can be held to the table with bolts. Others, D, are provided with steps which catch on the underside of the T-slots. These are inserted in the ends of the T-slot and then pushed along to the required position. The stops, illustrated at C, D, and E, are tapped to hold set screws which can be tightened directly against the work or can be used in connection with toe dogs (Fig. 110). The screws are set either straight or at an angle, those set straight usually being used to take the thrust of the tool and the ones inclined at an angle used to exert a downward pressure when the work is being held.

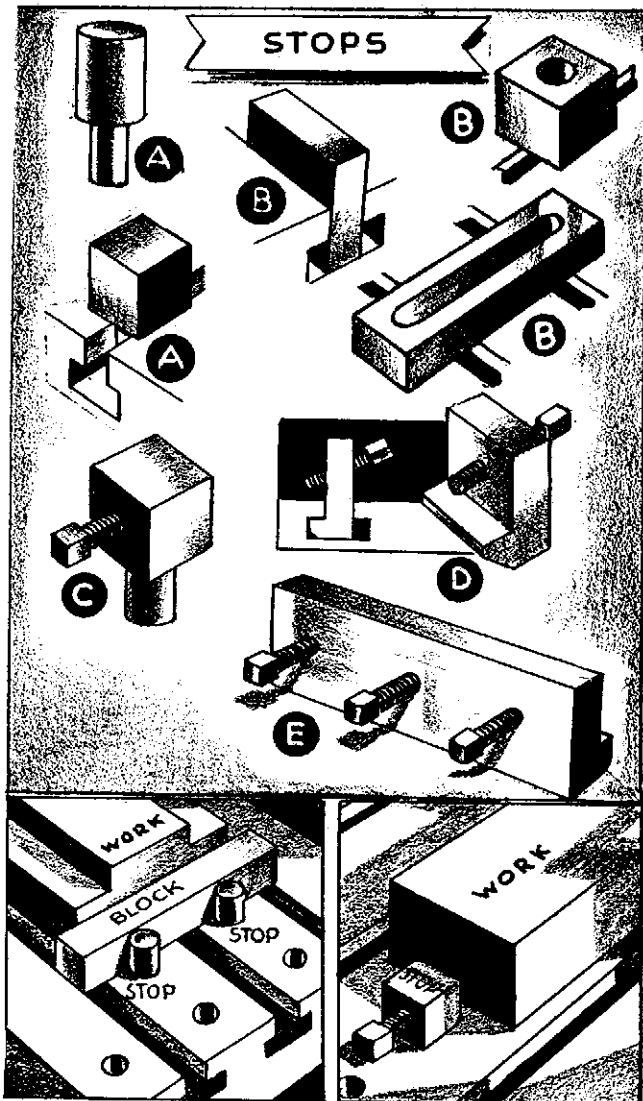

FIG. 109

TOE DOGS

A similar method of holding work is employed when thin material is held on the table with toe dogs (Fig. 110). The dogs are forged from round stock with either a flat end as shown at A or a pointed end as shown at B. At the opposite end, a counterbored hole is made to receive the end of a screw which is used to force the toe dog against the work. The narrow edge or the point of the dog, whichever is used, allows clearance for the tool when thin metal is being planed, while the slight angle at which the dog is set holds the work securely to the table.

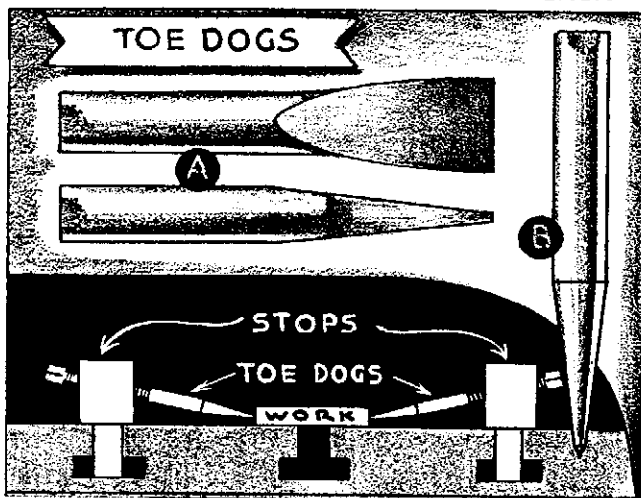

FIG. 110

HOLD-DOWNS

Hold-downs (Fig. 111) are thin, wedge-shaped pieces of hardened and ground steel used principally to hold work in the vise. The larger edge, which is placed against the vise jaws, is ground at an angle of 92° with the underside; the thin contact edge is left square with the bottom, or, in some cases, is rounded slightly. When the job and the hold-downs have been placed in position, and the jaws of the vise have been tightened, the hold-downs are tilted slightly, a position which forces the work down on the supporting surface.

This method is used to hold flat work which cannot be held conveniently by other methods. It is especially suitable for holding thin metal and for holding a job when a small amount is to be removed from the surface. With this arrangement, the work can be held securely without distortion, and, at the same time, there is ample room for manipulating the shaper tool.

ALIGNING STRIPS, OR BARS

Aligning strips (Fig. 112) are placed on the shaper table as a guide to setting the work parallel, at 90° , or at an angle to the direction of the stroke. They may be used also as stops against which the end of the material may be placed when duplicate lengths are being cut off from a piece of stock. Aligning strips can be plain bars, as illustrated at A and B. They may both be held to the table with clamps and bolts and, in the case of B, with bolts which pass through the slot. These strips may be located and set in any desired position on the table, but they should be securely braced with stops to prevent their shifting if the work is held against the strips with set screws.

The two styles of aligning strips illustrated at C and D are provided with tongues which fit into the table slots. This limits the use of these strips to being set parallel with the travel of the tool as shown in the inserts E and F. The tongues, however, make possible a quick and easy alignment of the strips par-

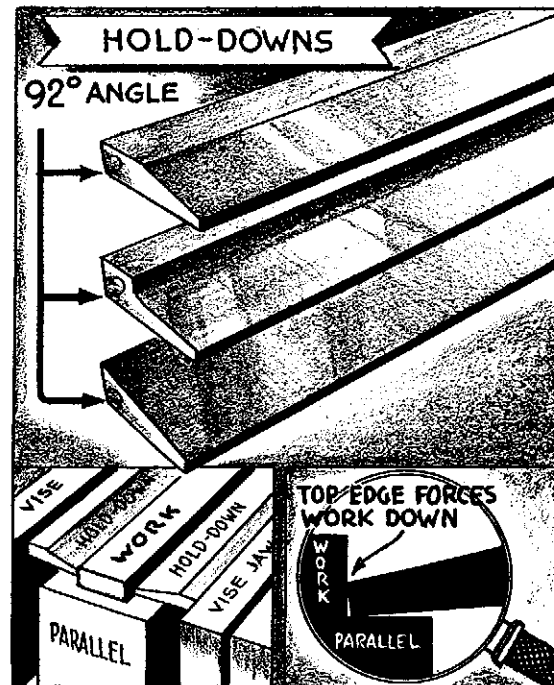

FIG. 111

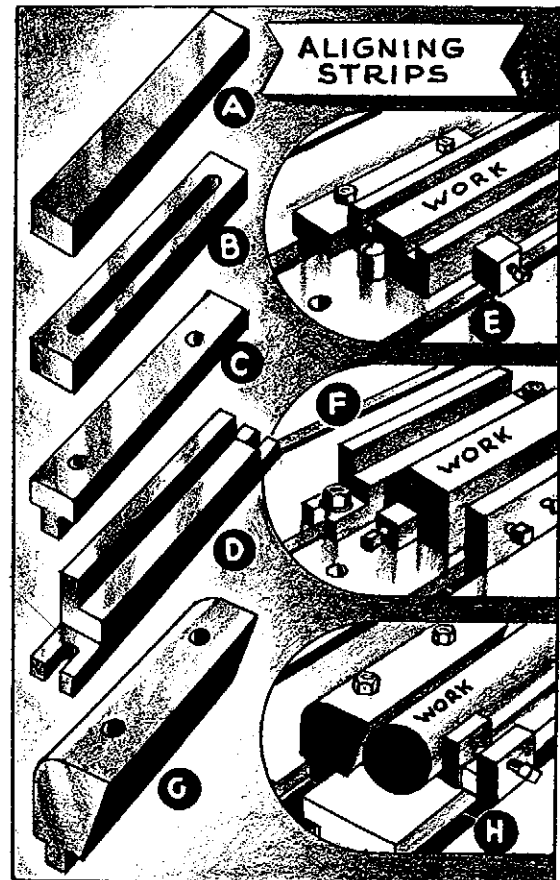
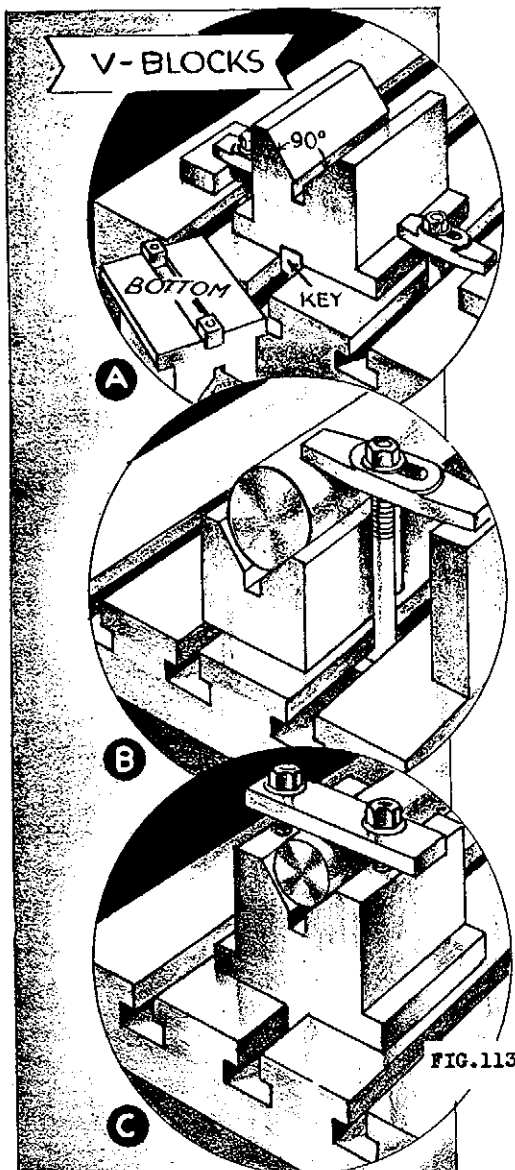

FIG. 112

allel with the direction of the cut. In addition, the tongues prevent the strips from shifting. The aligning strip shown at F may be reversed so that the high side of the strip also can be placed against the work.

To locate and align round shafting on the shaper table, the angular aligning strip shown at G is sometimes used. The strip is aligned parallel with the direction of the cut by placing the tongue of the strip in the table slot H. Bolts secure the strip to the table. The sloping face of the aligning bar is made so that it will form an angle of about 80° with the top of the table. When the round shaft is forced against the bar by the screws of the stops, the shaft will in turn be forced downwards by the slope of the bar. A binding piece is inserted between the screw and the shaft to protect the shaft from the end of the screw and to present a flat surface for the point of contact. As the center of the screw is above the center of the shaft, the packing block is placed at the bottom of the binding piece.



V-BLOCKS

In addition to the method of placing shafts and round pieces directly on the shaper table, round work may be held in rectangular blocks with 90° V-shaped openings cut in one or more of their sides. Shafts are usually many times longer in proportion to their diameters, and for this reason two blocks are ordinarily used to support the work. As the openings resemble a V, they are called V-blocks (Fig. 113).

Although styles of V-blocks vary considerably, probably the two most practical styles are those illustrated at A and B. The one illustrated at A has a flange on the base, the ledge of which is used to support the point of the clamps when the block is clamped to the shaper table. On the underside of the block is a rectangular groove which is cut the entire length of the V-block and into which square blocks, or tongues, are inserted and held in place with screws. The tongues project below the undersurface of the V-block so that when it is placed on the table the tongues fit into the table slot and align the V-block parallel with the direction of the cut. Although this is an advantage, it limits the position of the V-block to placing it central with the table slots. Because of the spacing of the slots on the table, frequently the clamping bolts cannot be placed near enough to the work that they are intended to clamp.

For this reason the tongues can be removed from the underside of the V-block so that they can be placed nearer to the clamping bolts. Although it is a simple matter to remove the tongue, nevertheless it saves time to have available V-blocks without tongues, as illustrated at B. With this style, the flange also has been omitted so that the V-block can be placed as close to the clamping bolt as possible. Time and care, however, are required to align, or set, this style of V-block in the desired position.

Occasionally, special V-blocks such as those illustrated at C can be used. This type of V-block has the advantage of having tongues so that it can be aligned quickly and accurately with the direction of the stroke. It also is provided with flanges which permit it to be clamped to the table. In addition, it carries its own clamping device to hold the work in position and thus eliminates the necessity of shifting the V-block so that the clamping bolts can be placed near the work.

ANGLE PLATE

Work and odd-shaped castings which must be held at right angles to a finished surface can be held by clamping the finished surface to an L-shaped device called an angle plate (Fig. 114). These angle plates are made either of steel or cast iron and are accurately machined to an angle of 90° . Usually angle plates for shapers are made of cast iron with a rib in the center to support the two adjoining sides and with elongated holes through which bolts pass to hold the work to the angle plate and to bolt the angle plate to the table.

On the underside of the base of the angle plate B are cut two rectangular slots at 90° to each other. Into these slots tongues or keys may be fitted and held in position with screws. The tongues may be placed in either one of the slots, depending on whether the angle plate is to be placed parallel or at 90° with the direction of the cut.

The bolt slots in the base are cut parallel with the length of the angle plate so that when the tongues are located in the T-slot, as illustrated at A, the holes will extend over to the adjacent T-slots.

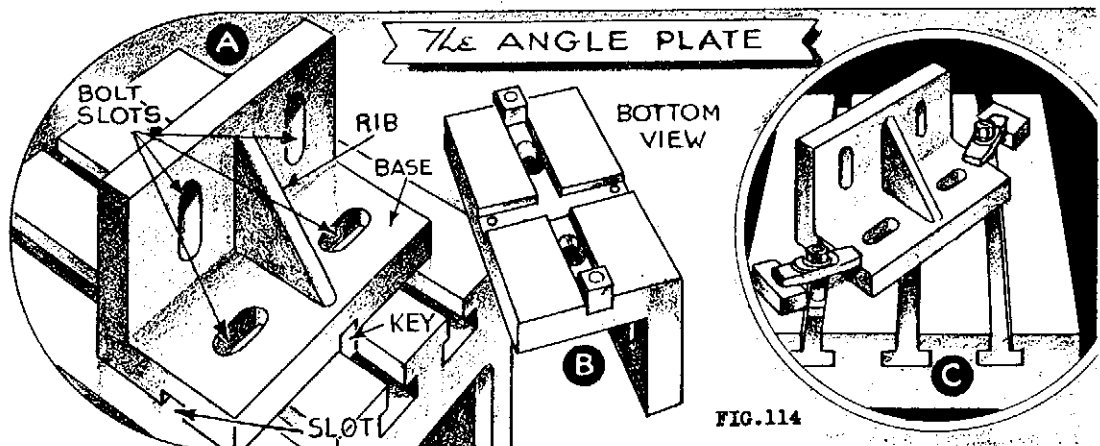

Whenever it is necessary to set the angle plate on the shaper table

at an angle with the direction of the cut, the tongues may be removed entirely from the rectangular slots. To avoid the necessity, therefore, of changing and removing the keys, an angle plate, C, with a plain base may be used. Also, because of the position of the angle plate on the table, it may not be possible to use the bolt holes in the base, for in order that the bolts may pass through the angle-plate slots, they must coincide with the table slots. If this should be the case, the angle plate must be fastened to the table with clamps. Stops also may be necessary to prevent the plate from shifting. Often, however, by rearranging the setup or by shifting the angle plate slightly on the table, one of the bolts may be utilized to hold one side of the plate and clamps may be used to secure the remaining portion. Furthermore, bolts which pass through slots or bolt holes have a greater gripping power because of their direct gripping action as compared with the lever action of the clamp, and should be used whenever practical when two surfaces are being clamped together.

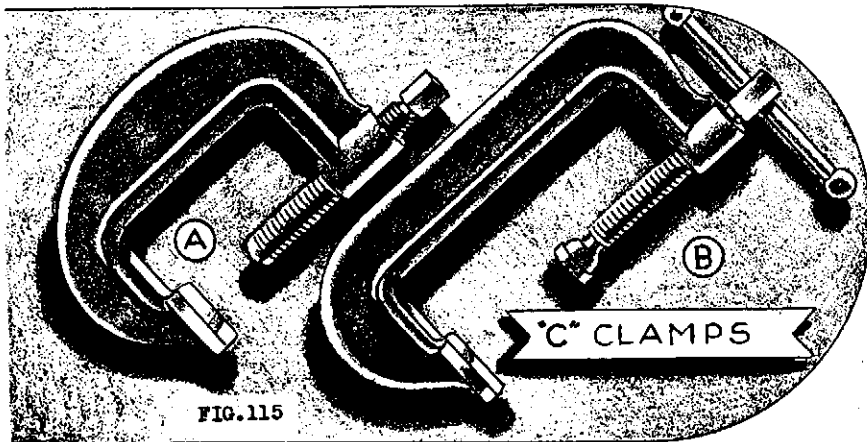

C-CLAMPS

There are times when clamps and bolts cannot conveniently be employed to hold parts together, and for this reason other clamping devices have been designed which may be substituted. One of these devices is the C-clamp illustrated in Fig. 115. As the name implies, it is shaped like the letter C. The clamp should be made of tough steel and heat

treated after forging to increase its strength and to reduce any tendency to spring. The parts to be held together are clamped between the pad and the end of the screw, and when pressure is applied by turning the screw, the pieces are held tightly together.

The C-clamp illustrated at A is a heavy-duty clamp with a plain screw and, consequently, unless some means is used to protect the surface being clamped, the end of the screw will mar the surface. This may or may not be objectionable. To overcome this, the screw in clamp B is provided with a swiveled end so that when the end of the screw makes contact with the work it stops rotating but allows the screw to continue to turn and apply additional pressure. Added protection for the surface being clamped may be obtained by placing a piece of soft metal or cardboard under the swiveled end of the screw and another piece on the pad of the clamp. The swiveled end of the screw has an additional feature in that it allows the swiveled end of the screw to align itself against a tapered or an irregular surface.

The styles of clamps vary considerably. For light clamping pur-

poses, the one illustrated at B can be used, whereas for use when considerable clamping pressure is required, the heavy-duty clamp illustrated at A is preferable. Special styles may be purchased as desired.

When the size of the clamp is being designated, the distance between the end of the screw and the pad of a fully opened C-clamp is called the capacity; the distance from the center of the screw to the inside edge of the C-clamp is termed the throat. Ordinarily, C-clamps are made with narrow throats because there is less strain on the clamp when the distance from the screw to the back of the clamp is short. Should it be necessary that the screw applying the clamping pressure be at some distance from the edge of the clamped surface, then a C-clamp with a deep throat must be used. C-clamps are quickly and easily adjusted, and are convenient and handy when used in the correct situation.

MACHINIST'S CLAMPS

Another style of clamp that is used considerably is the machinist's, or parallel, clamp (Fig. 116). This clamp is especially suitable when the pieces to be held together are parallel and have a machined finish.

The machinist's clamp consists of two screws and two jaws which embody the same principle of gripping as do the clamps and the bolts (Fig. 199) with the exception that the machinist's clamp is self-contained and needs no additional support. Screw C takes the place of the supporting block in Fig. 199 and can be adjusted to suit the width of the surfaces to be clamped; and, similarly, screw D is substituted for the clamping bolt which is used to apply the clamping pressure. The shoulder of the center screw D has been made convex to rest on a concave seat which is cut in the outer side of the jaw A. This construction allows the jaws to tilt slightly. The end of the screw C is turned down to fit loosely into a blind hole that is drilled in the face of the jaw and toward the end.

The jaws are made of tough, drop-forged steel, and, together with the screws, are heat treated to increase their strength. Both holes in the jaw B are threaded; the holes in the jaw A are plain. When the clamp is adjusted properly, it holds very securely, and if a strip of soft metal or cardboard is placed between the jaws and the clamped surface, the jaws of the clamp will not mar the work. The machinist's clamp is light, handy, and convenient, but not particularly powerful.

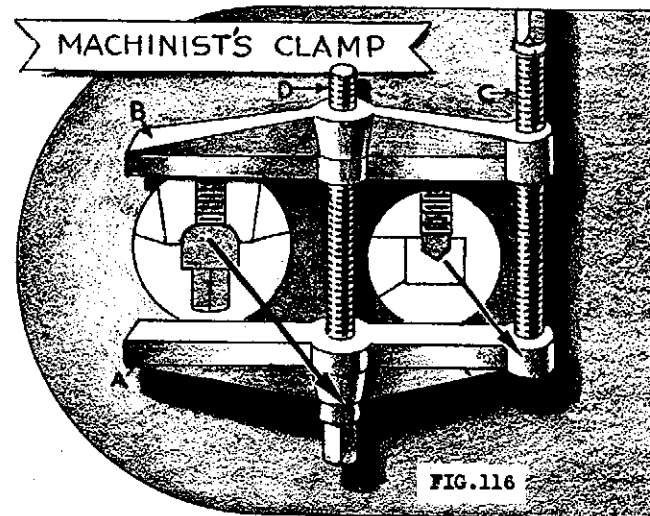

JACKS

JACKS

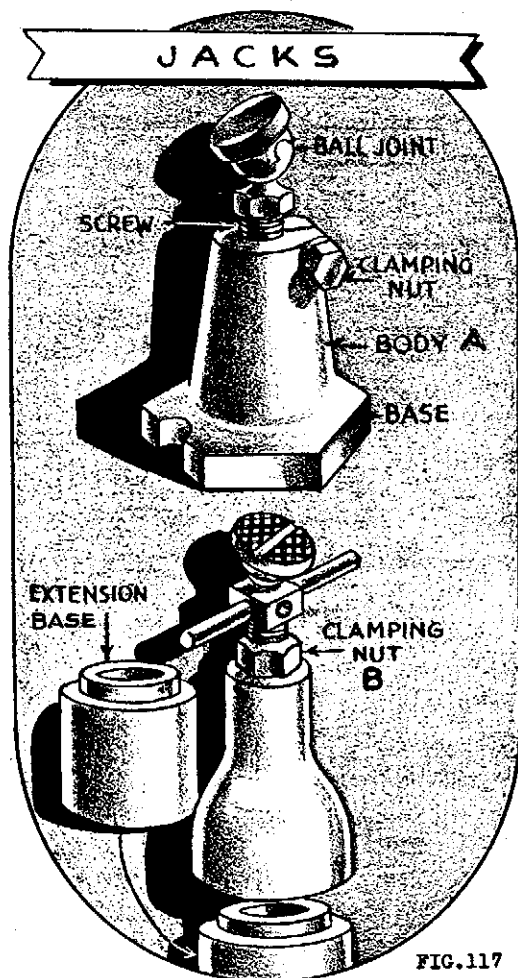

FIG. 117

In spite of all the clamping devices and methods of holding work on the shaper table, it is not always possible to level work or to support overhanging pieces properly without the aid of a jack (Fig. 117). A jack can be easily slipped under the work, the screw adjusted to the height of the supported surface, and then the screw locked in position so that it does not jar loose.

The body of the jack A is threaded to receive the screw which may be raised or lowered by turning. The screw has a ball joint at the top which allows the end to swivel and to bear evenly against the surface of the work.

Without some form of locking device, the screw of the jack would be jarred loose by the vibration of the machine. To overcome this, the body of the jack is split at the upper end so that when the clamping nut is tightened the threaded portion of the screw is gripped and held securely. This, however, is not the only type of locking device. Sometimes an extra nut is placed on the screw near the top of the jack as illustrated at B. After the top of the screw has been set to the

height of the supported surface, this extra nut is given a partial turn clockwise. Thus the screw is locked tightly by being drawn against the thread in the body of the jack.

Jacks are made in various sizes to accommodate different heights of work. If a jack is not high enough to reach the work, a small jack may be placed on a block, or an extension base may be used.

When a bolt and clamp are used to hold an overhanging surface, a jack placed underneath the work makes a very suitable support. Jacks, then, are a very convenient means of leveling, bracing, and supporting work. A set of them should always be available, especially when a large variety of work must be set up on the shaper table.

SHIMS AND WEDGES

Whenever a rough casting or uneven work is secured directly to the shaper table, the uneven surfaces must be supported to prevent rocking. It is especially important to have a solid foundation under

the part to be clamped. This support will prevent any spring or distortion due to the pressure of the clamps. As these spaces are usually small, thin strips of metal, wood, cardboard, or paper, called shims, are used as packing.

Sometimes it is more practical to use a wedge, which is a piece of steel thinner at one end than at the other. The thin end of the wedge can be inserted into the space and then tapped slightly to make a solid base. When work must be leveled on the table, the wedge is often preferable because the low spot can be easily raised by inserting a wedge at the proper place and tapping or driving it in as may be required. Although wedges and shims can be made of almost any material, they are usually made of metal.

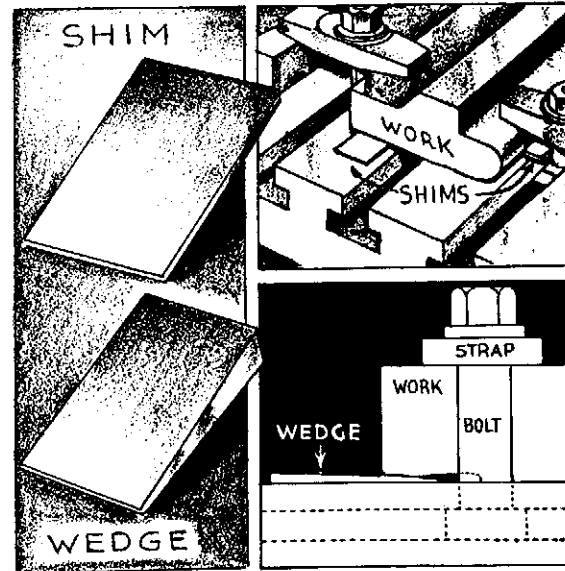

FIG.118

PACKING AND STEP BLOCKS

Square or rectangular blocks are used to support straps, or clamps, at the end opposite the work. As the clamp must be level to obtain maximum gripping power, blocks are made in various sizes so that they can be used singly or in combination and in such a manner that the height of the supporting surface corresponds to that of the work. Usually packing blocks are made of metal; however, wood blocks are often substituted.

To suit the various heights to which the end of the clamp must be supported, the step block with its series of raised surfaces is an exceedingly handy piece of equipment. Although it is difficult, in all cases, to foretell at what height the clamp must be supported, nevertheless, the slight variation between the height of the selected step and the height of the work can be eliminated by putting a thin packing strip between the clamp and the step to be used.

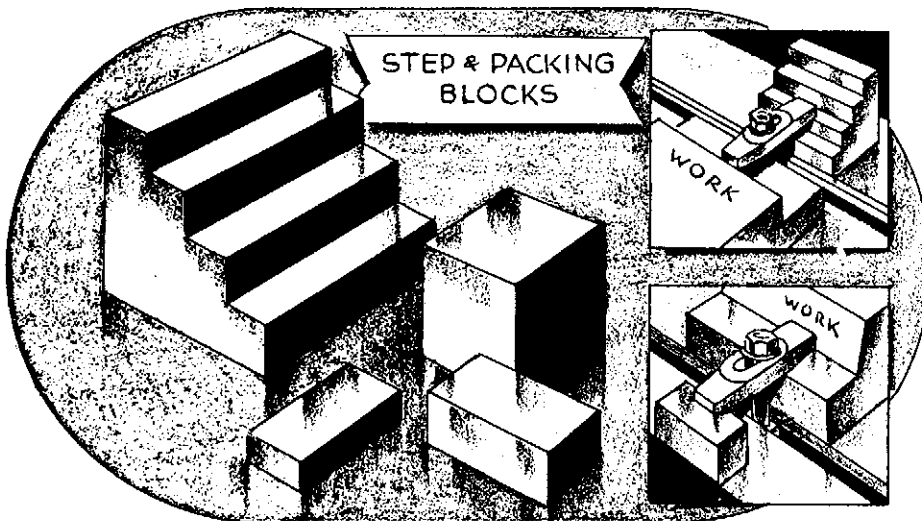

FIG.119

FIXTURES

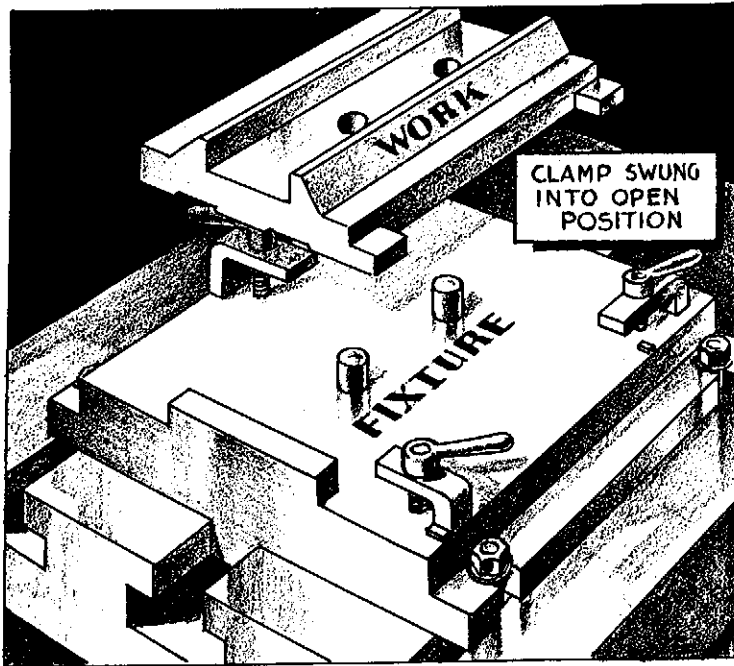

FIG. 120

A fixture (Fig. 120) is a special device designed to hold irregularly shaped jobs which cannot be held by the usual methods and to hold pieces which are required in large quantities.

Both the fixture and the tool are moved during shaper-machining operations and for this reason a fixture for shaper work is used principally as a holding device. The larger fixtures are usually fastened to the table; the smaller ones are often held in the vise.

A good fixture is made so that the work is located accurately, secured quickly and firmly, and released easily.

Whether or not a fixture should be used depends upon many factors. If there are a large number of pieces to be made and if the cost per piece can be reduced by using a fixture, one may be justified. Odd-shaped pieces that are awkward to handle and require considerable time to set up may often be easily and quickly clamped in a fixture. On the other hand, to make a fixture for one or two pieces, even if the pieces are difficult to hold by the usual methods, does not, as a rule, warrant the cost.

SPECIAL VISE JAWS

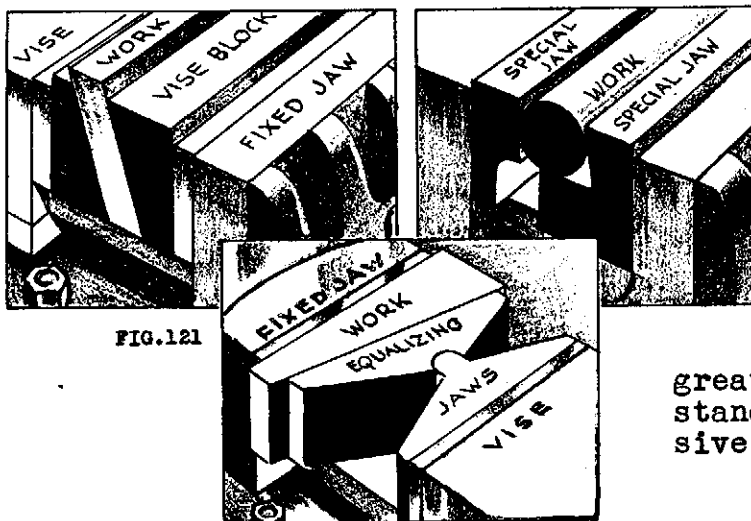

FIG. 121

Special vise jaws and shaped vise blocks, although not ordinarily classified as fixtures, have a great many possibilities for holding work which would be difficult to hold in any other way. Only three simple examples are given in Fig. 121, but it should be remembered that these types of holding devices have a great many adaptations and in many instances can be used instead of expensive fixtures.