

955,206.

Patented Apr. 19, 1910.

2 SHEETS—SHEET 1.

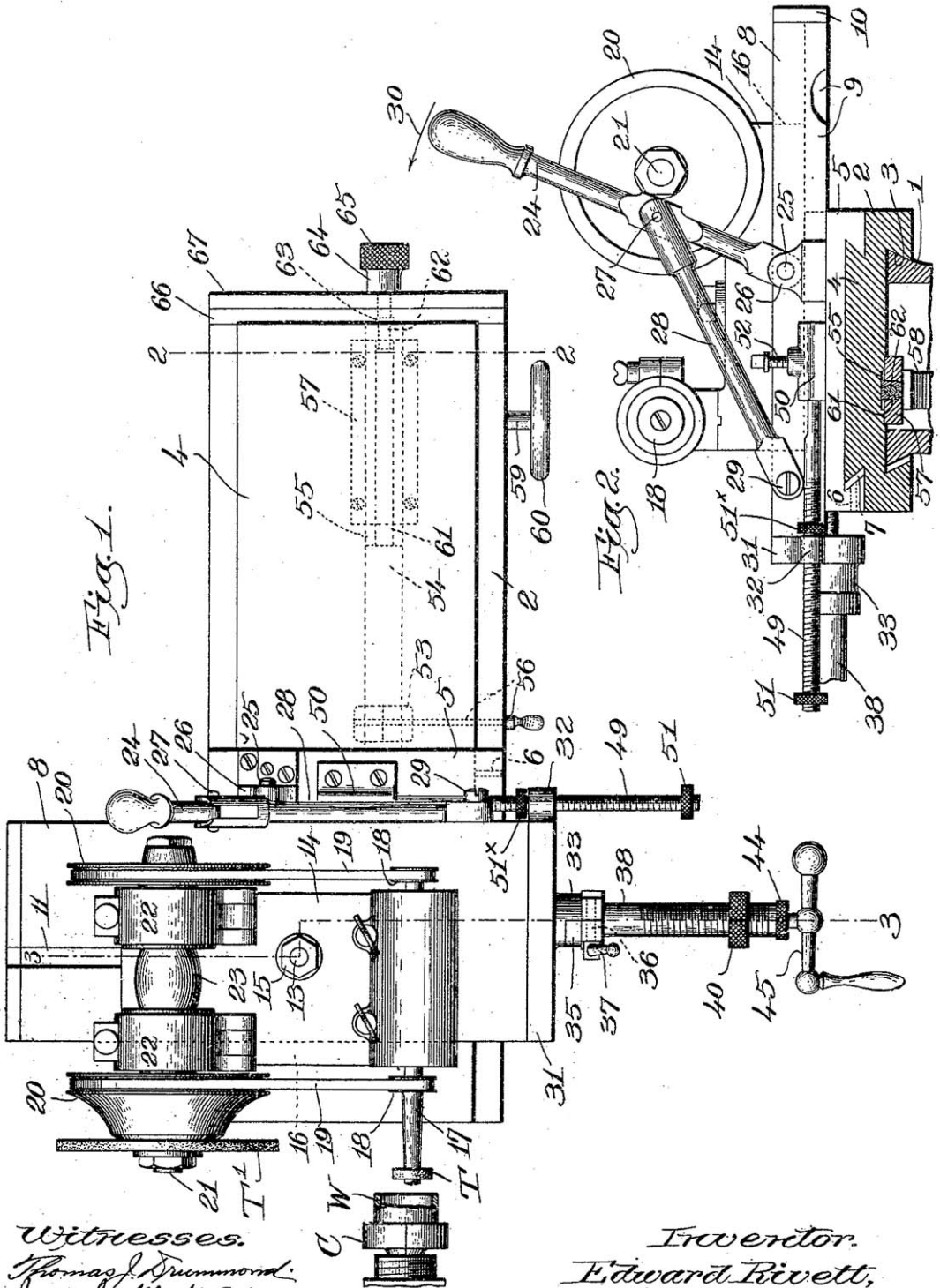

Fig. 1.

Fig. 2.

Witnesses:
 Thomas Drummond,
 Joseph M. Ward.

Inventor:
 Edward Rivett,
 by Henry Seymour, atty.

955,206.

Patented Apr. 19, 1910.

2 SHEETS—SHEET 2.

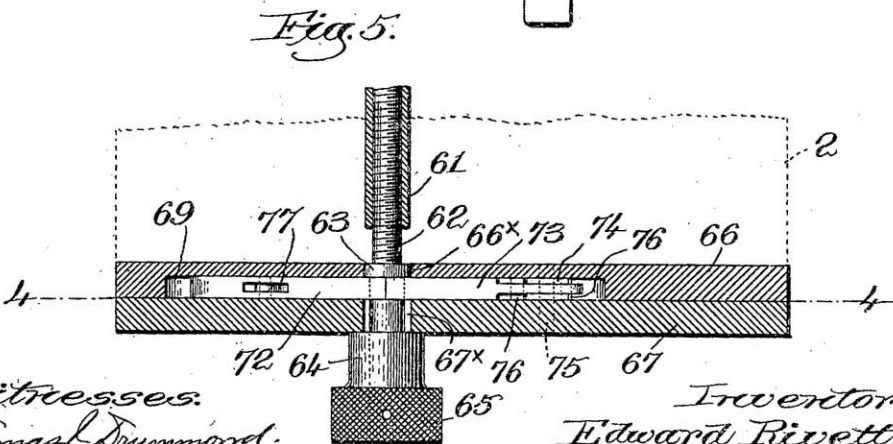
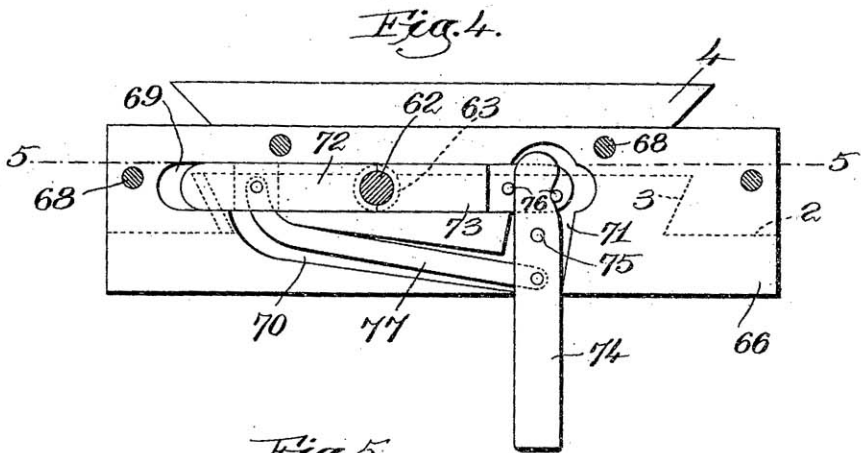
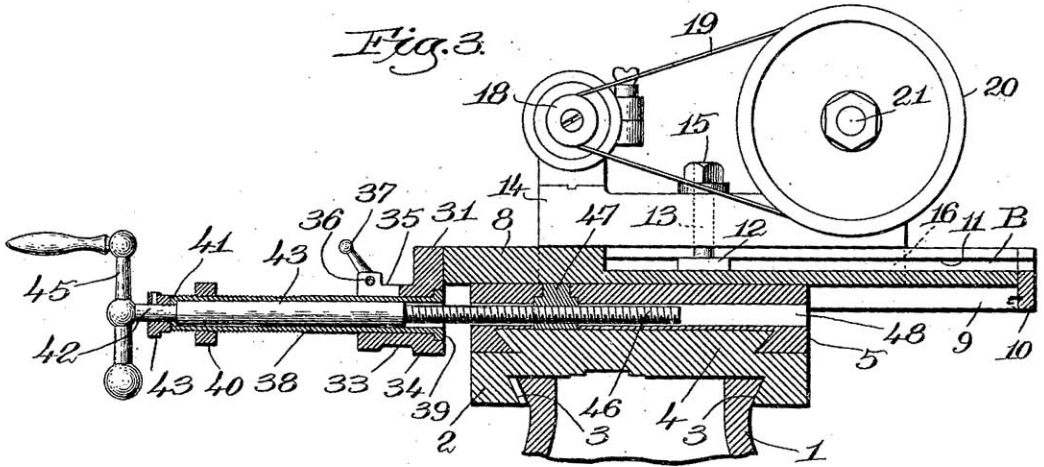

Witnesses:
 Thomas Drummond,
 Joseph M. Ward.

Inventor:
 Edward Rivett,
 by Lewis Dugouy, atty.

UNITED STATES PATENT OFFICE.

EDWARD RIVETT, OF BOSTON, MASSACHUSETTS.

GRINDING OR POLISHING MACHINE.

955,206.

Specification of Letters Patent. Patented Apr. 19, 1910.

Application filed August 23, 1909. Serial No. 515,001.

To all whom it may concern:

Be it known that I, EDWARD RIVETT, a citizen of the United States, and resident of Brighton, Boston, county of Suffolk, State of Massachusetts, have invented an Improvement in Grinding or Polishing Machines, of which the following description, in connection with the accompanying drawing, is a specification, like characters on the drawing representing like parts.

This invention has for its object the production of a grinding or polishing machine containing various novel features of construction and arrangement whereby the operation of the machine as a whole is improved and its adjustment and manipulation readily and quickly effected.

My invention relates to that type of grinding and polishing machine wherein the grinding or polishing tool is mounted on a rotatable carrier or spindle, and the object to be acted upon is mounted in a similar manner, with means for effecting a relative reciprocation of the carriers longitudinally and for varying the relative position of such parts laterally.

In the present embodiment of my invention I have provided a plurality of carriers or spindles, rotatably supported in a head which is bodily movable with a carriage adapted to be reciprocated automatically on the usual bed or base of the machine, and such head is also capable of manually-controlled movement transversely to the carriage to bring into operative position one or another of the tools mounted on the carriers or spindles.

By mounting on one carrier a tool for external grinding or polishing, and upon another carrier a tool for internal grinding or polishing I am enabled, by the manually-controlled shifting movement referred to, to quickly position either tool for coöperation with the work, and thereafter to effect the feed of the tool.

The various novel features of my invention will be fully described in the subjoined specification and particularly pointed out in the following claims.

Figure 1 is a top plan view of a grinding or polishing machine embodying my present invention, only a small portion of the work-holder or chuck being shown as it forms no part of the present invention; Fig. 2 is a transverse sectional detail on the line 2—2,

Fig. 1, looking toward the left; Fig. 3 is a detail partly in elevation and partly in section on the line 3—3, Fig. 2, showing the means for effecting the feed movement of the head and cause the tool to coöperate properly with the work; Fig. 4 is an enlarged detail on the line 4—4, Fig. 5, of the locking device for the adjustable carriage-stop, to be referred to; Fig. 5 is a horizontal sectional detail of such device, on the line 5—5, Fig. 4.

The main frame or bed 1, Figs. 2 and 3, is of suitable shape to sustain the operating parts of the machine, its top being shaped to form a guide-way for the carriage 2, undercut at 3 to embrace the bed and slidable longitudinally thereupon, the top of the carriage being shaped to present a guide-way 4 having undercut sides, upon which is sustained a base 5. This base may be shifted lengthwise of the carriage 2, when desired, by loosening a set-screw 6 which bears against a gib 7, the base under normal conditions being fixedly secured to the carriage.

Upon the base 5 is seated a broad, elongated and heavy plate 8 having its longer dimensions transverse to the carriage 2, said plate constituting a cross-slide, having depending parallel flanges 9, 9 which embrace the opposite sides of the base 5, and a transverse stop-flange 10, Fig. 3, the flanges 9 serving to guide the slide in its movements on the base.

A longitudinal, undercut slot 11 is formed in the top of the cross-slide, extending for a part of its length, to receive the head 12 of a retaining bolt 13, see Fig. 3, the bolt extending vertically through a hole in a head 14, which seats on the cross-slide and is clamped thereto by a nut 15 on the bolt, the head having a depending guide-rib 16, see dotted lines, Figs. 1, 2 and 3, overhanging one side of the slide.

When the nut 15 is set up the head 14 is rigidly clamped upon the cross-slide, to move therewith as a unit, but as will be obvious the head can be adjusted longitudinally of the cross-slide to suit various conditions of work.

A tool-carrier or spindle 17 is rotatably mounted in suitable bearings in the head, and is arranged to carry a grinding or polishing tool T, Fig. 1, arranged for acting upon the interior of the work W, which is held in any suitable work-holder or chuck C.

Pulleys 18 on the spindle receive belts 19 driven by larger pulleys 20 on a second tool-carrier or spindle 21 mounted in bearings 22 on the head, an attached pulley 23 on spindle 21 being adapted to receive a belt, not shown, driven from any suitable source of power, a second grinding or polishing tool T', Fig. 1, mounted on the spindle 21 being herein arranged for acting externally upon the work.

As shown in Fig. 1 the tool T is in position to enter the work W and act upon the interior thereof as the carriage 2 is reciprocated longitudinally on the bed of the machine. If it is desired to bring the tool T' up into position to act upon the work the cross-slide 8 is moved forward, and the means for effecting such movement will now be described, together with the means for effecting the feed movement of the cross-slide and head after said parts have been moved manually to operatively position one or the other tool.

A swinging handle 24 is fulcrumed at 25, Figs. 1 and 2, in an ear 26 fixedly secured to the base 5, the handle having jointed to it at 27 a link 28 pivotally connected at 29 to the side of the cross-slide, and when the latter is unlocked from the cross-feeding means it can be moved forward, or to the left, Fig. 2, transversely to the carriage 2 by swinging the handle 24 in the direction of the arrow 30. Such movement carries the tool T ahead out of the way and brings the tool T' up into position to act upon the work.

The front end of the cross-slide 8 has a rigidly-attached depending flange 31 provided at one end with an eye 32, to be referred to again, and at the center of the slide said flange has a projecting hub 33, internally shouldered at 34, Fig. 3, and split to form a clamping part 35, Figs. 1 and 3, said hub being clamped or opened by means of a screw 36 having an operating handle 37.

An elongated sleeve 38 enters the hub and its annular head 39 seats against the shoulder 34, as shown in Fig. 3, the outer end of the sleeve being externally threaded to receive a stop-nut 40, which can be adjusted on the threaded part toward or away from the hub 33.

The outer end of the sleeve which receives a portion of the feed-screw, is internally and annularly shouldered at 41, and the reduced end 42 of the cylindrical body 43 of the feed-screw passes loosely through the shoulder and has fixed upon it a nut 44, so that said feed-screw can rotate in the sleeve but is held from longitudinal movement therein, a suitable handle 45 enabling the screw to be easily rotated to effect the cross-feed of the tool.

When the hub 33 is unclamped or opened it can slide freely longitudinally upon the sleeve 38 when the cross-slide 8 is moved by

means of the handle 24, but when the hub is clamped said cross-slide is locked from such movement, by the coöperation of the threaded portion 46 of the feed-screw with a nut 47 let into the base 5, the latter having a hole 48 therethrough to receive the threaded end of the feed-screw, shown in Fig. 3. It will now be apparent that by turning the feed-screw in one direction or the other the sleeve 38 together with the cross-slide and the head, will be moved transversely of the carriage 2 to effect the cross-feed of the tool then coöperating with the work, the longitudinal movement of the tool relatively to the work being effected by the reciprocation of the carriage 2.

The stop-nut 40 is set or adjusted on the sleeve to effect a preliminary position of the tool-carrier 21 with relation to the work when the quick shift or change from one to the other tool is to be made, so that if the tool T' is to be brought into operation the hub 33 is unclamped and the handle 24 is swung forward, thereby quickly moving the cross-slide and head to the left, Figs. 2 and 3, until the outer end of hub 33 abuts against the stop-nut 40, and the hub is then clamped on the sleeve 38, locking the cross-slide and head in position, after which the cross-feed of the tool T' is governed by rotation of the feed-screw, as described.

A reverse movement of the handle 24, back to the position shown in Figs. 1 and 2, after unclamping of the hub, carries the tool T into general operative position, the sleeve-head 39 then acting as a stop when it seats upon the shoulder 34 in the sleeve, and the cross-feed of the tool T is governed by the feed-screw after the hub and sleeve are clamped. I thus provide means for changing from one to the other tool quickly and easily, by a single movement of the handle 24 in one or the other direction, when the cross-slide is unlocked, such shift of the cross-slide and head bringing either tool into approximate operative position, so that thereafter the cross-feed of the tool, that is, its feed transverse to its axis of rotation, is wholly under the control of the operator through the feed-screw.

Were it not for the means provided for the rapid shift any change from one to the other tool would be a very slow operation, and dependent wholly upon the feed-screw.

Any additional setting of the head is provided for by shifting the head 14 upon the cross-slide as has been described.

Once the approximate adjustment has been made for the quick movement or shift of the cross-slide, for any given piece of work and the tools which are to act thereupon, it will be seen that the action of the tools upon duplicate pieces of work can be carried on with rapidity and accuracy. The sleeve 38 is thus an adjustable stop-carrying

member to determine the extent of the quick shifting movement of the cross-slide, and it also constitutes a part of the locking means for such cross-slide and the tool-carrying head thereon after the shift has been made and the cross-feeding of the tool is begun.

I have provided means to limit the cross-feed of the slide, so that when a cut of a predetermined depth has been made by the active tool further feed by means of the feed-screw is stopped. To this end a threaded rod 49 is loosely extended through the eye 32 and is fixed in a socketed block 50 on the base 5 by means of a set-screw 52, Fig. 2, and upon the outer end of said rod is mounted an adjustable stop-nut 51, a similar stop-nut 51^x being adjustably mounted on the rod between the eye and the block 50.

In practice the nut 51 is adjusted to abut against the eye 32 when the cross-feed of tool T' has caused it to make the proper depth of cut in the work, hence said nut is set somewhat beyond the stop 40, which latter serves to approximately position the tool T' with relation to the work, as will be remembered. In a similar manner the stop-nut 51^x is adjusted to abut against the inner face of the eye 32 when the tool T has been cross-fed to make its cut of proper depth in the work.

Reciprocation of the carriage 2 upon the bed of the machine may be effected in any suitable way, as for instance by the means shown in my United States Patent No. 623,742 dated April 25, 1899, a yoke depending from the carriage cooperating with an actuating cam, as therein shown, and in Fig. 1 I have shown in dotted lines at 53 the upper part of such a yoke, depending from the carriage 2.

In practice the axis of the actuating cam will be at right angles to the tool-carriers or spindles and the reciprocation of the carriage will be from right to left, Fig. 1, in parallelism with the tool-carrying spindles, as in my patent referred to, the feed stroke, to the left, being spring-actuated as by the spring *d*^s of the patent.

The top of the yoke is formed as a block 54, Fig. 1, which fits into a longitudinal groove 55 in the underside of the carriage, a clamping screw 56 serving to lock or clamp the yoke and carriage together while permitting an adjustment of said carriage relatively to the yoke, in order that the starting point of the stroke of the carriage may be varied, to suit different classes of work.

A rack-bar 57 is secured to the underside of the carriage below the outer end of said groove and having its teeth mesh with a pinion 58 carried by a shaft 59 mounted in the frame and provided with a suitable hand-wheel 60, and when the yoke is unlocked the carriage can be moved toward or away from the work, to bring about a change

in the relative position of the carriage and the yoke, the latter being locked to the carriage when the desired adjustment is made.

The rack-bar is longitudinally grooved to receive an elongated stop-bolt 61, square in cross-section and internally threaded to cooperate with a screw-threaded spindle 62 provided with a collar 63, Fig. 5, and with the hub 64 of a milled nut 65 secured to its outer end.

The spindle extends beyond the right-hand end of the carriage 2, as shown, and two transverse plates 66, 67 are secured to such end of the carriage in any suitable manner, as by screws 68, Fig. 4, the plates having alined holes 66^x, 67^x, through which the collar 63 can pass. Plate 66 is cut out or recessed to present a transverse portion 69, and connecting portions 70, 71, see Fig. 4, which recesses are covered by the plate 67.

Oppositely movable locking members 72, 73 are mounted to slide in the part 69 of the recess, the opposite ends of said members being semi-circularly notched to loosely embrace the part of the spindle 62 adjacent and outside of the collar 63, as shown in Figs. 4 and 5, so that the spindle can be rotated but it will be held from longitudinal movement relatively to the carriage, the hub 64 bearing against the outer face of the plate 67 to prevent inward movement of the spindle.

A handle 74 is fulcrumed at 75 in the part 71 of the recess in the plate 66, and at its upper end passes between lugs 76 projecting from the locking member 73, so that when the lower end of the handle is swung to the left, Fig. 4, the member 73 will be moved to the right and retracted beyond the path of the collar 63. By means of a link 77 pivotally connected with the handle and with the locking member 72 the latter will be moved simultaneously to the left, away from the spindle collar, the link lying in the part 70 of the recess. When the locking members are thus retracted the spindle 62 is released, and by grasping the nut 65 the spindle and the bolt 61 can be drawn outward relatively to the carriage, or the carriage can be moved inward relatively to said parts if the inner end of the bolt is abutting against the block 54 which forms the top of the yoke 53.

Suppose that the carriage and yoke have been adjusted with the end of the bolt 61 against the block 54, as shown in dotted lines, Fig. 1, and the yoke has been clamped to the carriage, the spindle 62 also being locked from longitudinal movement by the locking members 72, 73, so that the carriage has the proper travel for a certain piece of work. It may then be desired to temporarily alter the travel of the carriage, while a part of the work is being treated, and then to resume the original travel. If the carriage is to be moved to the left the yoke is

unclamped and by the handle 74 the spindle 62 is unlocked, so that rotation of the hand wheel 60 will move the carriage to the left the proper distance, the yoke-block 54 holding the bolt 61 and spindle 62 from movement while the collar 63 passes through the plate 66. Then the yoke is clamped and the machine is started, to complete the particular operation upon the work, after which the yoke is again unclamped from the carriage and the latter is moved to the right, Fig. 1, by means of the rack-bar and pinion, until the spindle 62 can be relocked. At such time the bolt 61 is in its former position relative to the carriage, and when the latter is moved to bring the bolt against the yoke-block 54 the carriage will be in position to be again clamped to the yoke.

Were no means provided to quickly lock and unlock the bolt-adjusting spindle 62 it would be necessary to rotate said spindle by hand if the carriage was required to be set over temporarily to the left, Fig. 1, and thereafter opposite rotation of the spindle would be necessary to restore the carriage to its former position, both operations consuming considerable time.

A close and exact adjustment of the carriage relatively to the yoke can be made by the spindle, as will be manifest, the spindle-locking members at such time being in their operative position, shown in Figs. 4 and 5.

It will be understood that when the carriage is unclamped to be adjusted relatively to the yoke the latter will continue to be vibrated by the opposed forces of the actuating cam and the spring, as in my prior patent.

In setting up the machine to act upon a certain piece of work, and frequently in starting the grinding or cutting operation, or in acting upon some particular part of the work, it is necessary to effect the longitudinal feed of the tool manually, and wholly under the control of the operator, by means of the hand-wheel 60 and the rack and pinion described, and when this is done the carriage is unclamped from the yoke. But as the latter continues to vibrate the yoke-block 54 would tend to intermittingly strike the stop bolt 61, so at such time I unlock the spindle 62, pull it outward or to the left, Fig. 1, until the bolt 61 is out of the range of the yoke-block, and effect the manually-controlled longitudinal feed or movement of the carriage 2 and the parts carried thereby until I am ready to begin the regular longitudinal movement of the carriage through the coöperation of the cam and yoke. Thereupon I push in the spindle 62, lock it in place by the means described, bring the stop-bolt 61 into engagement with the yoke-block, and clamp or lock together the yoke and the carriage. This is a matter of great convenience as it enables me to put

the carriage under manual control whenever desired, and at such time the manipulation of the apparatus is effected with the greatest ease and with entire freedom from interference by the main carriage-actuating mechanism.

From the foregoing description it will be understood that the stop-bolt 61 does not in any way serve to limit the reciprocation of the carriage, for normally the bolt and the yoke-block 54 move in unison with each other and with the carriage, but said bolt does act as a positioning stop for re-setting the carriage relatively to the yoke after said parts have been unclamped and their relation changed temporarily, as previously explained.

The plate 67 serves as a cover for the recessed plate 66 and to protect the locking means for the spindle 62, the member 72, 73 being held in proper position by the plate 67. As the said locking members are connected with the operating handle 74 at opposite sides of its fulcrum 75 the opposite sliding movement of the locking members is effected by swinging the handle in one or the other direction.

My invention is not restricted to the precise construction and arrangement herein shown and described, as various changes or modifications may be made by those skilled in the art without departing from the spirit and scope of my invention as set forth in the annexed claims.

Having fully described my invention, what I claim as new and desire to secure by Letters Patent is:—

1. In a machine of the class described, a work-holder; a longitudinally reciprocated carriage; a head movable therewith and manually movable transversely thereto; a plurality of tools carried by and at the same side of the head; means to shift the head transversely of the carriage to thereby bring one or another of the tools into operative position relatively to the work-holder, and separate means to effect cross-feed of the head for the operatively positioned tool.

2. In a machine of the class described, a carriage provided with means to reciprocate it; a head movable therewith; a plurality of rotatable tool-carriers mounted on the head in parallelism with the path of movement of the carriage; a tool on each tool-carrier; means to bodily shift the head transversely of the carriage to bring one or another tool into operative position; adjustable stops to limit such movement, and manually-operated means to effect cross-feed of the head for the tool carried thereby which is operatively positioned.

3. In a grinding or polishing machine, a work-holder; a carriage adapted to be reciprocated in parallelism with the axis of said work-holder; a head movable with the

carriage and also shiftable transversely thereon; a plurality of tool-spindles rotatably mounted in the head; means to shift the head quickly from one to the other of its extreme positions, to bring one or the other tool into approximate operative position; separate, manually-operated means to effect cross-feed of the head after the same has been shifted, and adjustable stops to determine the extent of the cross-feed.

4. In a grinding or polishing machine, a head; a pair of rotatable, parallel carriers mounted thereon; a tool secured to each carrier; a carriage on which the head is mounted, said carriage being movable to effect longitudinal feed of said tools; means to effect a quick shift of the head transversely of the carriage, to bring one or the other tool into position to operate, and a slow-motion cross-feed for the head when in either of its shifted positions.

5. In a grinding or polishing machine, a head; a pair of rotatable, parallel carriers mounted thereon; a tool secured to each carrier; a carriage on which the head is mounted, said carriage being movable to effect longitudinal feed of said tools; means to effect a quick shift of the head transversely of the carriage, to effect approximate operative positioning of one or the other tool; adjustable stops to limit such shifting movement of the head; manually operated means to effect cross-feed of the head in either of its shifted positions, and adjustable stops to limit the extent of such cross-feed.

6. In a machine of the class described, a carriage adapted to be reciprocated longitudinally; a cross-slide movable with the carriage and shiftable transversely thereon; a head fixedly mounted on the cross-slide; a pair of rotatable tools carried by the head with their axes parallel to each other and to the path of movement of the carriage; manually-actuated means to shift the cross-slide and thereby bring one or the other tool into position to operate; means to effect cross-feed of the said slide and head in either of its shifted positions, and a device to lock the carriage after each shift and thereby place it under the control of the cross-feeding means.

7. In a machine of the class described, a carriage adapted to be reciprocated longitudinally; a cross-slide movable with the carriage and shiftable transversely thereon; a head fixedly mounted on the cross-slide; a pair of rotatable tools carried by the head with their axes parallel to each other and to the path of movement of the carriage; manually-actuated means to shift the cross-slide and thereby bring one or the other tool into position to operate; a manually-operated cross-feed screw permanently connected with the carriage; a sleeve-like support for said screw, in which it is rotatable while held

from longitudinal movement; means to lock said support and the cross-slide to move in unison when the feed-screw is to be operated, said support and slide being unlocked for shifting of the latter, and means to stop the shifting movement of the cross-slide when a tool is approximately positioned for operation.

8. In a machine of the class described, a carriage adapted to be reciprocated longitudinally; a cross-slide movable with the carriage and shiftable transversely thereon; a head fixedly mounted on the cross-slide; a pair of rotatable tools carried by the head with their axes parallel to each other and to the path of movement of the carriage; manually-actuated means to shift the cross-slide and thereby bring one or the other tool into position to operate; a manually-operated cross-feed screw permanently connected with the carriage; a sleeve-like support for said screw, in which it is rotatable while held from longitudinal movement; means to lock said support and the cross-slide to move in unison when the feed-screw is to be operated, said support and slide being unlocked for shifting of the latter; means to stop the shifting movement of the cross-slide when a tool is approximately positioned for operation, and independent, adjustable means to limit the extent of cross-feed of the slide after shifting movement thereof.

9. In a machine of the class described, a carriage adapted to be reciprocated longitudinally; a cross-slide movable with the carriage and shiftable transversely thereon; a head fixedly mounted on the cross-slide; a pair of rotatable tools carried by the head with their axes parallel to each other and to the path of movement of the carriage; means, including a swinging, manually-actuated handle, to shift the cross-slide and thereby present one or the other tool to act upon the work; a manually-operated feed-screw permanently connected with the carriage; a device to lock and unlock said feed-screw and the cross-slide, whereby the latter can be quickly shifted when unlocked and positively controlled, when locked, by said feed-screw, to effect the cross-feed of the operating tool; and adjustable means to determine the extent of cross-feed.

10. In a machine of the class described, a carriage adapted to be reciprocated longitudinally; a cross-slide movable with the carriage and shiftable transversely thereon; a head fixedly mounted on the cross-slide; a pair of rotatable tools carried by the head with their axes parallel to each other and to the path of movement of the carriage; quick-motion means to effect a rapid shift of the cross-slide and present one or the other tool to act upon the work; and separate, slow-motion means to effect cross-feed of the slide and the operatively-positioned tool.

11. In a machine of the class described, a carriage adapted to be reciprocated longitudinally; a cross-slide movable with the carriage and shiftable transversely thereon; a head mounted on the cross-slide; a pair of rotatable tools carried by the head with their axes parallel to each other and to the path of movement of the carriage; quick-motion means to effect a rapid shift of the cross-slide and present one or the other tool to act upon the work; separate, slow-motion means to effect cross-feed of the slide and the operatively-positioned tool, and a device to lock together the cross-slide and said slow-motion means after shifting of the cross-slide is effected.

12. In a machine of the class described, a carriage adapted to be reciprocated longitudinally; a cross-slide movable with the carriage and shiftable transversely thereon; a head adjustable on the cross-slide in the direction of shifting movement of the latter; a pair of parallel, rotatable tool-carrying spindles mounted on the head and each provided with a tool, said spindles parallel to the path of movement of the carriage; quick-motion means to effect a rapid shift of the cross-slide and head to present one or the other tool to act upon the work; separate slow-motion means to effect cross-feed of the slide in either of its shifted positions; and means to operatively connect the slow-motion means and the cross-slide after the same has been shifted.

13. In a grinding or polishing machine, a rotatable work-holder; a carriage adapted to be reciprocated in parallelism with the axis of rotation of said work-holder; a head movable with and also transversely upon the carriage; two rotatable tools mounted on the head, to act upon the interior and exterior of the work, respectively, and manually-controlled means to effect a quick shift of the head upon the carriage to bring one or the other tool into position to act upon the work, combined with means to effect cross-feed of the operatively positioned tool after quick shift of the head.

14. In a machine of the class described, a bed; a carriage longitudinally movable thereon; a tool rotatably mounted on the carriage; actuating means for the carriage, including a yoke detachably connected with said carriage; an adjustable stop-bolt mounted on the carriage to determine the relative position of the carriage and yoke, and means to temporarily throw the bolt out of cooperation with the yoke while maintaining the adjustment of the bolt.

15. In a machine of the class described, a bed; a carriage longitudinally movable thereon; a tool rotatably mounted on the carriage; a continuously-vibrating yoke having an attached block; means to clamp together the block and carriage to effect recip-

rolocation of the latter; a positioning bolt mounted on the carriage, to cooperate with the yoke-block and determine the relative position of the carriage and the yoke when clamped; an adjusting screw cooperating with and to position the bolt, and means to temporarily throw said bolt out of action with relation to the yoke-block while maintaining the adjustment of the bolt.

16. In a machine of the class described, a bed; a carriage longitudinally movable thereon; a tool rotatably mounted on the carriage; a continuously-vibrating yoke; means to clamp together the yoke and carriage to effect reciprocation of the latter; an adjusting screw mounted on the carriage; means to lock it from relative longitudinal movement while permitting rotation thereof; and a bolt controlled by said screw and adapted to cooperate with the yoke to determine the relative position thereof and the carriage when clamped, unlocking of the screw permitting retraction thereof with the bolt to allow movement of the carriage independently of the yoke when the latter is unclamped, the adjustment of the bolt on the screw being maintained during such retraction.

17. In a machine of the class described, a bed; a carriage longitudinally movable thereon; a tool rotatably mounted on the carriage; a continuously-vibrating yoke; means to clamp together the yoke and carriage to effect reciprocation of the latter; an adjusting device mounted on the carriage, to cooperate with the yoke and determine its position relative to the carriage when clamped thereto, and manually-controlled means to permit temporary bodily retraction of the adjusting device to inoperative position when the yoke and carriage are unclamped, whereby the carriage can be moved freely relatively to said yoke.

18. In a machine of the class described, a bed; a carriage movable longitudinally thereon; a continuously-vibrating yoke; means to clamp it to the carriage to reciprocate the latter; an adjusting device mounted on the carriage, to cooperate with the yoke and determine its position relative to the carriage when clamped thereto; manually-controlled means to permit temporary bodily retraction of said device to inoperative position when the yoke and carriage are unclamped, whereby the carriage can be moved freely relatively to the yoke, and means to reciprocate by hand the carriage when unclamped.

In testimony whereof, I have signed my name to this specification, in the presence of two subscribing witnesses.

EDWARD RIVETT.

Witnesses:

JOHN C. CONNOR,
FREDERICK S. GREENLEAF.