

RIVETT

608

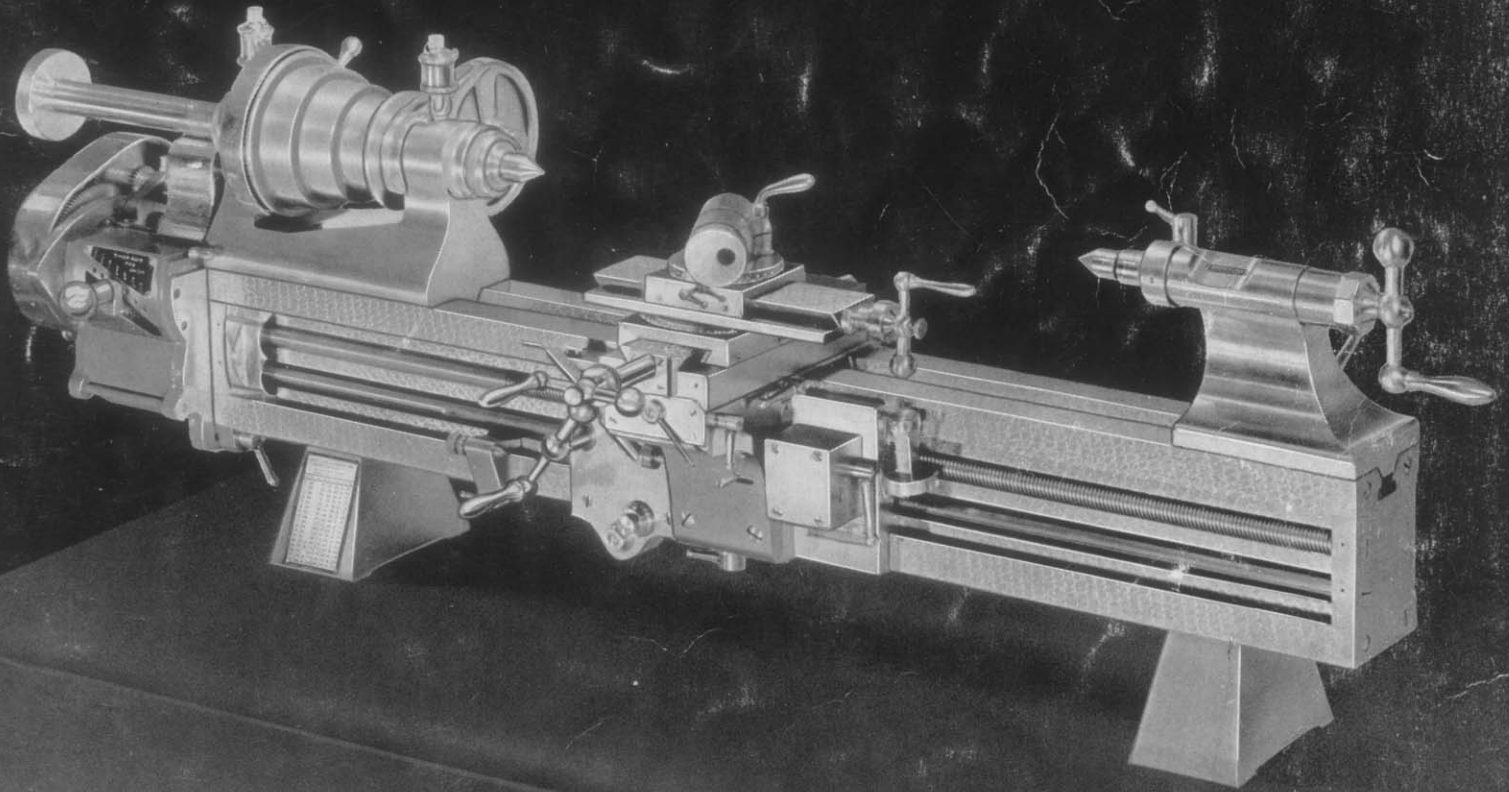

RIVETT LATHE & GRINDER Inc.
BRIGHTON • BOSTON • MASS • U • S • A •

BULLETIN 608 E

RIVETT 608

PRECISION BACK GEARED SCREW CUTTING LATHE

The first Rivett precision screw cutting lathe was made in 1888. For fifty years its builders have sought to perfect its every feature in pace with the progress of the times. Long experience in service throughout the world and the demands for closer limits of accuracy than were dreamed of by our forefathers have dictated increasing fineness of workmanship. Improvements in available materials and in measuring and inspecting instruments have contributed to its development.

The aim of the engineers who sponsor it today is to offer a machine capable of producing in laboratory, on shipboard or in manufacturing department a very wide range of true precision parts—"The Master Workman's Master Tool."

But their ambition is not limited merely to making a lathe which when new will be the most accurate product of its type. A much less costly design would answer that requirement. The "608" is built today as in the past by expert mechanics. Every component part is rigidly checked. The assembly is critically tested for performance within the guaranteed limits and above all "608" is so proportioned as to retain its inherent accuracy through years of intelligent use,—to embody long-life precision.



RIVETT LATHE & GRINDER INC.

BRIGHTON, BOSTON, MASS., U.S.A.

BULLETIN 608E

PAGE

1

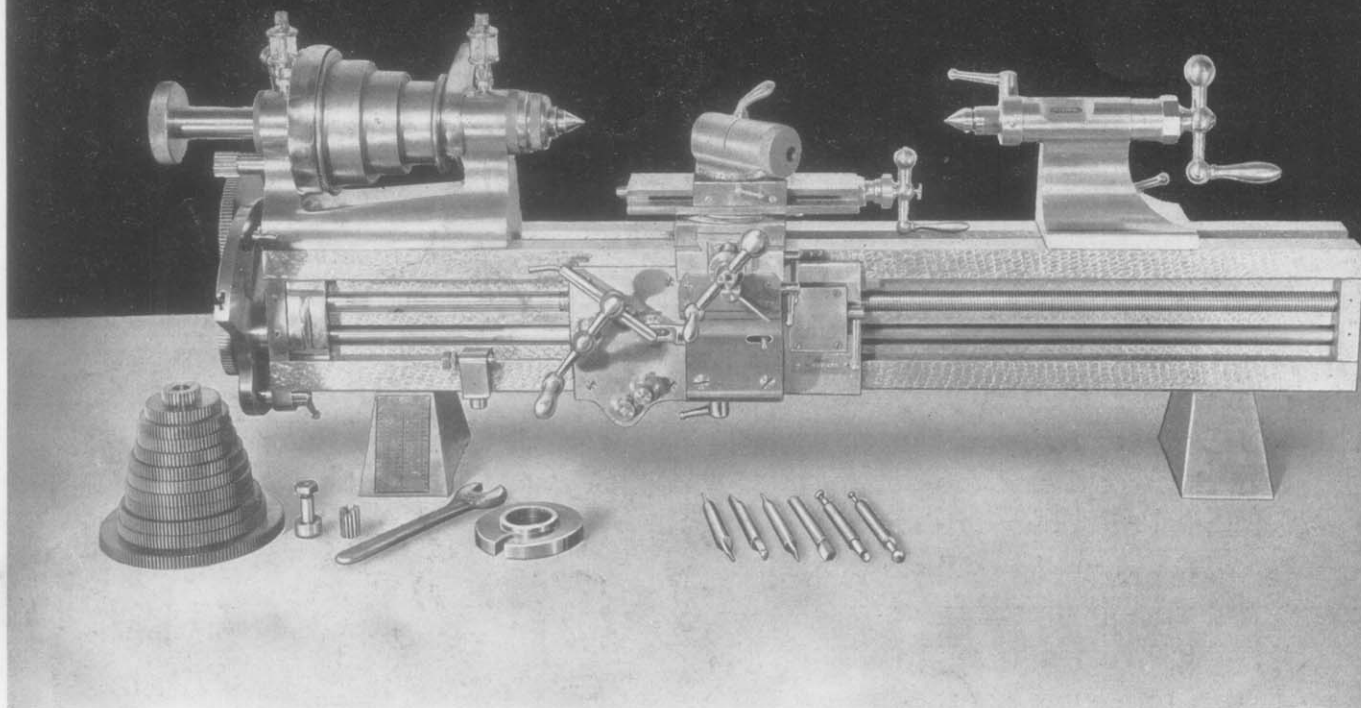

Fig. 1

608-4-NS CHANGE GEAR LATHE

The Rivett 608 precision back-geared screw cutting lathe with change gear system is a simple yet versatile machine known throughout the world for its enduring accuracy. Manufacturers, governments and scientists employ it for fine production, repair and experimental work. A greater number of modern mechanical marvels have been developed on this small lathe than on all other machine tools combined. Technical instructors of machine shop practice in engineer training departments and in vocational schools and colleges find "608" the finest demonstrator for teaching the construction, working principles and functions of lathes. In tool-making and instrument shops it will handle a great variety of jobs in minimum time. The super-finish of the lathe is not for appearance only but to inspire the high order of maintenance which it deserves.

Basically, "608" is a small but exceedingly powerful engine lathe. As such it is peculiar in having slide areas equal to those of other lathes twice its size. Its bronze-bearing spindle runs more smoothly and with greater truth than any anti-friction bearing spindle and is capable of heavy or light cuts and severe end thrusts. Finely-made attachments for milling, spiral cutting, slotting, relieving, taper turning, ball turning, grinding and forming enable the user of a fully equipped "608" completely to finish his work without recourse to other machines and throughout his entire series of operations to utilize the inherent precision of the lathe itself.

The change gear type, by simple and compound gearing, affords great flexibility through an extreme range of thread pitches, standard and odd. Electrical manufacturers cut threads as fine as 260 per inch on "608."

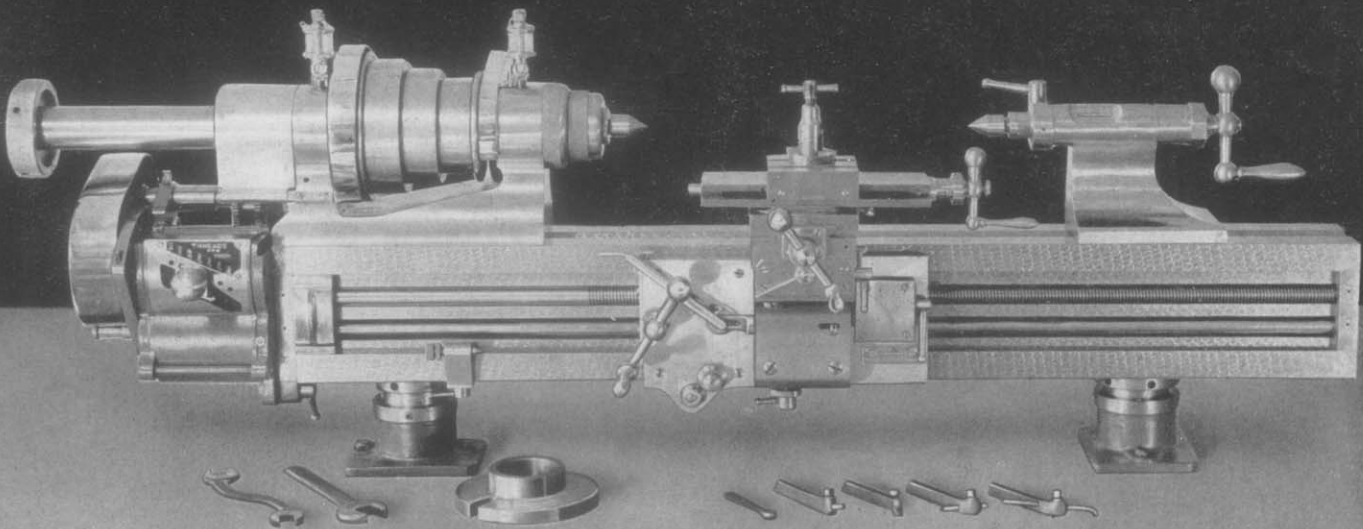

Fig. 2

608-5-C QUICK CHANGE GEAR BOX LATHE

The "608" quick change lathe substitutes a gear box unit for the change gear system and thus accommodates itself to the manufacture and reproduction of small threaded work and to turn, bore or face fine surfaces on a quantity basis. Like the change gear lathe, it is built in $\frac{5}{8}$ " and 1" collet capacities and is furnished with either eccentric or rocker slide rest. Safety interlock protects the carriage from accidental engagement of both power feed and lead screw at one time; lead screw and feed rod are guarded from injury by their deeply inset mounting in bed, and the full front and wide rear slide areas, which by reason of their vertical disposition minimize the adherence of abrasive particles, vitally supplement the horizontal top surfaces of the bed in guiding the carriage which itself is fitted with wipers to sweep away dirt and chips. Three-point pedestal

supports assure against distortion imparted from lathe mount.

The "608", whether change gear or gear box type, may be driven through speed box, by vertical endless belt from below, as in Figs. 47, 48 and 49, or by horizontal safety countershaft, Figs. 44 and 45, or overhead arrangement, as in Fig. 51. On cabinet, bench or oil pan it becomes a unit combining compactness, ease of set-up and commanding dependability.

The "608" is so rigidly designed, so powerfully constructed and so easily handled that it will produce not only small precision parts but surprisingly heavy work, usually put on large lathes, without the least injury to itself.

And when in the course of years it shows signs of wear, it can be entirely restored to its original perfect condition by rebuilding, for in fact it is a lathe for a lifetime.



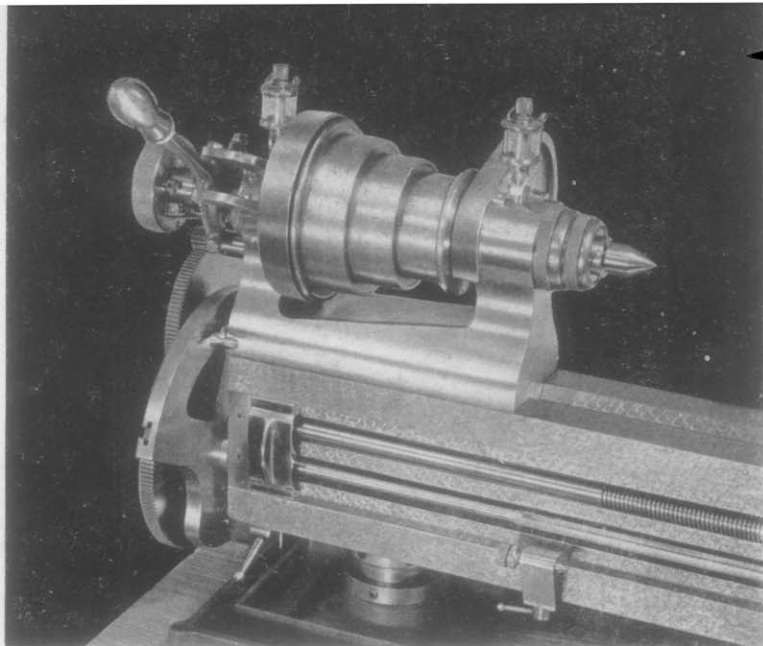

Fig. 3

HEADSTOCKS

The headstock is made from a one piece casting scraped and firmly bolted in alignment to the bed. Heat-treated and ground spindle is furnished in two sizes, $\frac{5}{8}$ " collet capacity, Fig. 3, and 1" collet capacity, Fig. 4, and is mounted in hard bronze bearings. The front bearing is double cone having angles of 3° and 45° with the center line. End thrust is taken by the 45° taper. Rear bearing has a straight hole and is tapered on the outside and split. Both bearings are self-centering when adjusted to compensate for wear. Exhaustive tests, in comparison with anti-friction and other types, have proved that Rivett two-taper bronze bearings best meet the exacting needs of "608". The mouth, chuck seat and threaded nose are ground with spindle running in its own bearings, thus insuring the highest degree of truth. The thread draws chuck plate or other spindle nose attachment snugly over a straight ground diameter back of thread and squares and locks same against a ground shoulder on the spindle.

The headstock is back-gearred affording a wide range of selective forward and reverse spindle speeds through gears or open belt,—see spindle speed tables, Figs. 46, 50 and 52.

Change gears, Fig. 3, or quick change gear box, Fig. 4, are driven from the headstock spindle and are arranged to run in either direction or to be thrown out when not needed.

Change Gears

The change gears are carried on the yoke and are driven by

stud gear. The yoke is tee-slotted and swivably mounted to permit set-ups for cutting full range of threads,—see gear tables, Pages 28 and 29. With single translating gear and supplemental change gears, complete range of metric threads may be cut with 8 pitch lead screw and, conversely, English threads may be cut with 3 m.m. pitch lead screw.

Gear Box

The quick change gear box is a sturdy, compact mechanism so devised and mounted as not to interfere with vertical belt from underneath drive or telescopic driving shafts used with spiral and relieving attachments. It may easily be replaced, in the event of accidental injury, or substituted on old lathes for the change gear system.

By sliding the stud and compound gears to proper detented positions and moving index lever to appropriate settings, thirty different threads from 10 pitch to 144 pitch are available through gear box. By mounting pick-off gears on auxiliary quadrant provided, additional threads may be cut. Such pick-off gears for $11\frac{1}{2}$, 15 and 27 pitch threads are included with standard lathe equipment,—see gear table, Fig. 54, Page 28. A plate in front of gear box indicates location of lever for pitch of thread. As with change gear system, metric translating gear is available.

LEVER CHUCK CLOSER

Lever chuck closer as shown in Figs. 3 and 4 quickly and uniformly opens and closes collet and step chuck and materially reduces wear on chuck and draw-in spindle threads, as well as assuring uniform draw-in of duplicate parts having uniform diameters.

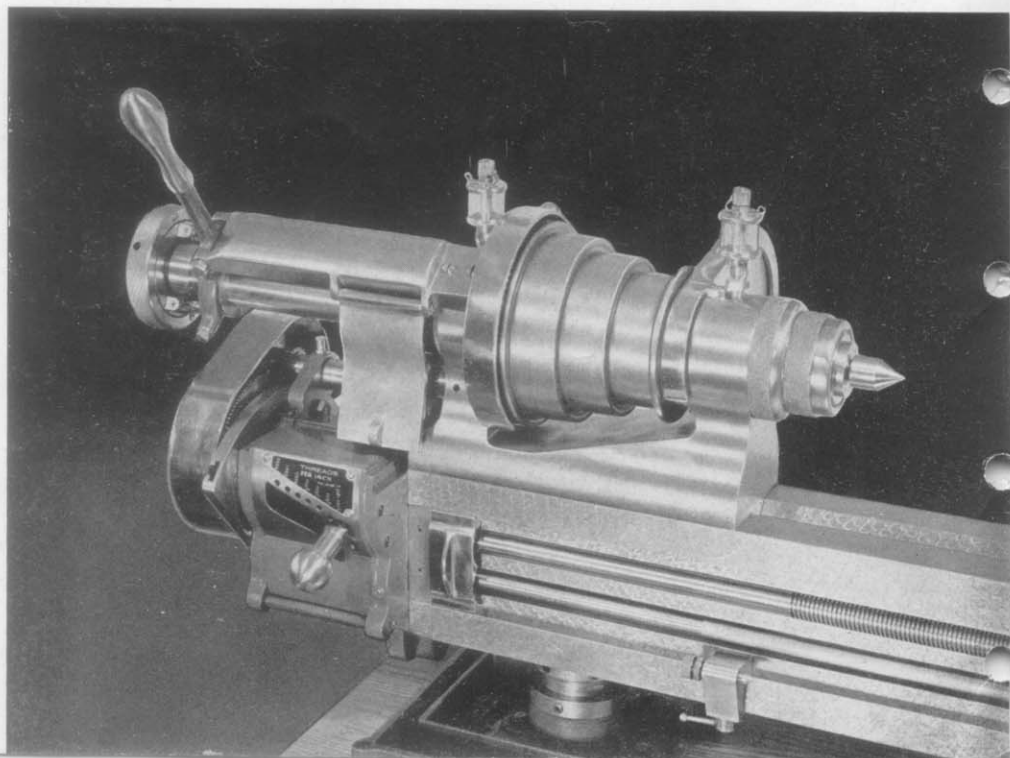

Fig. 4

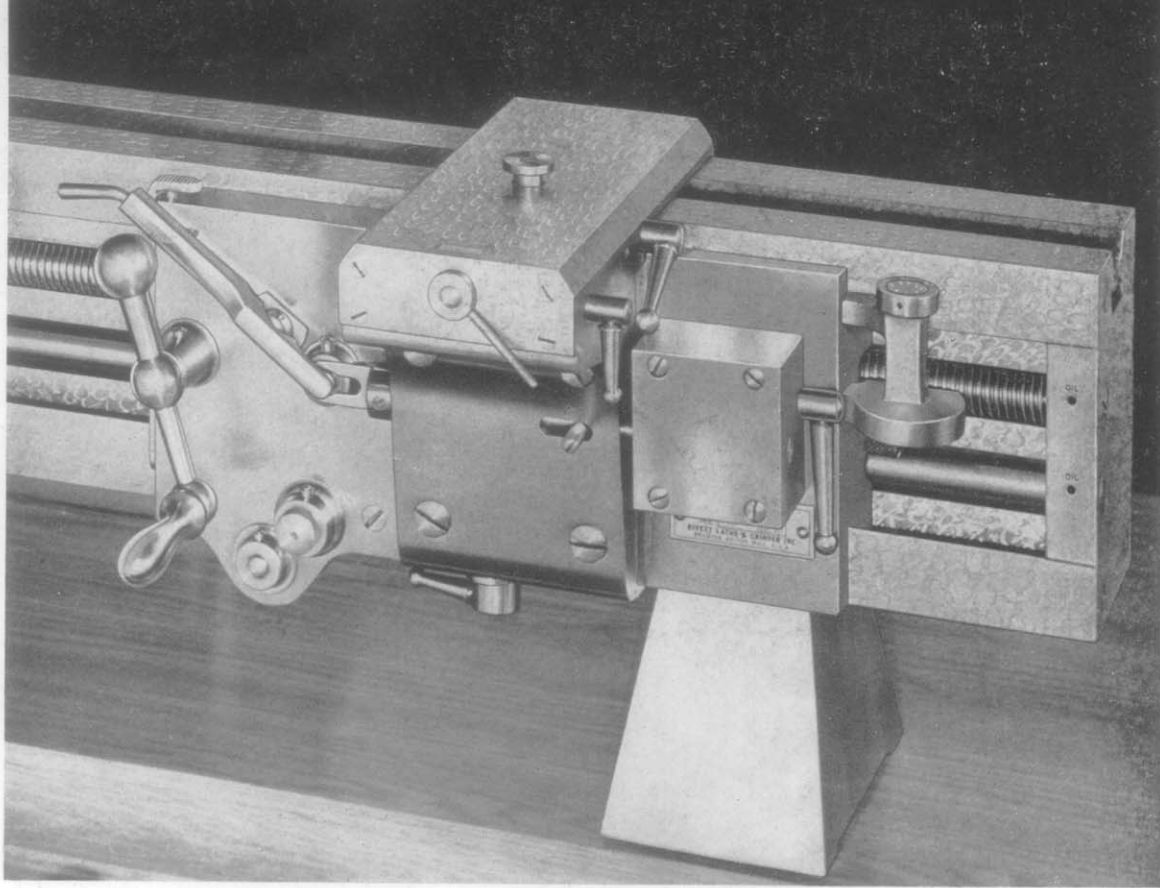
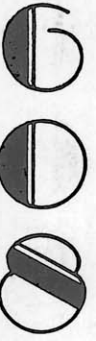

Fig. 5

BED

The bed is made from a strongly ribbed box casting of close-grained alloyed iron. The top is entirely hand-scraped to a true plane with a central V-guide-way to locate the headstock, tailstock and attachments in proper alignment. The dovetail and plane surfaces on the front, and plane surface on the rear of bed are hand-scraped to serve as guides for the carriage,—all these slide and guide areas, aggregating 76 square inches, being finished in most accurate possible relation to each other by employment of surface-plating and gaging devices which assure an equalization of bearing fundamental to long precision life. The lead screw has bearings in the end plates and is supported in a groove throughout its entire length to prevent error in carriage position due to sagging of screw. Lead screw is furnished with $\frac{1}{8}$ " pitch or 3 m.m. metric pitch as specified. An independent feed rod with a sliding gear provides power feed for the carriage without employing the lead screw, thus preserving the precision quality of the latter. The left end of the bed carries a yoke for change gears in Model 608-P.A., Fig. 1, or a quick change gear box in Model 608-P.B., Fig. 2, for thread cutting and power feeding. A spherical washer in tailstock pedestal and two steel balls transversely located at headstock pedestal provide three point mounting which prevents distortion. With underneath drive, screw jack pedestals as shown in Fig. 2 replace plain pedestals shown in Fig. 1.

CARRIAGE AND SADDLE

The carriage is of bridge type with large slide areas on the rear, top and front of the bed, Fig. 5. The front vertical dovetailed guideway and rear surface bearings are gibbed to compensate for wear. The carriage saddle has angular guideways scraped to provide positive and accurate mounting for the slide rest and attachments. Four wipers on the carriage automatically clean the dovetail and flat bearing surfaces of the bed. The synthetic wiping material is oil-proof.

When cutting threads, a bronze half-nut, controlled by an eccentric lever, engages the lead screw. A threading dial attachment, Fig. 5, is offered to pick up threads without reversing the lathe. Power longitudinal feed is from the feed rod through a friction clutch and gears to a rack. This clutch is controlled by a latched lever and may be released either by hand or automatically by contact with an adjustable stop. A safety interlock is provided to prevent simultaneous engagement of lead screw and feed rod. When cutting very accurate threads the carriage gear train may be stopped and drag eliminated by disengaging a pull-out gear. Micrometer carriage stop can be furnished in place of standard screw stop. Hand longitudinal movement of the carriage is accomplished by a ball crank handle geared to the rack.

Power cross feed is thrown in by a lever actuating a cam which raises the connecting gear into mesh with the cross slide screw driving pinion.

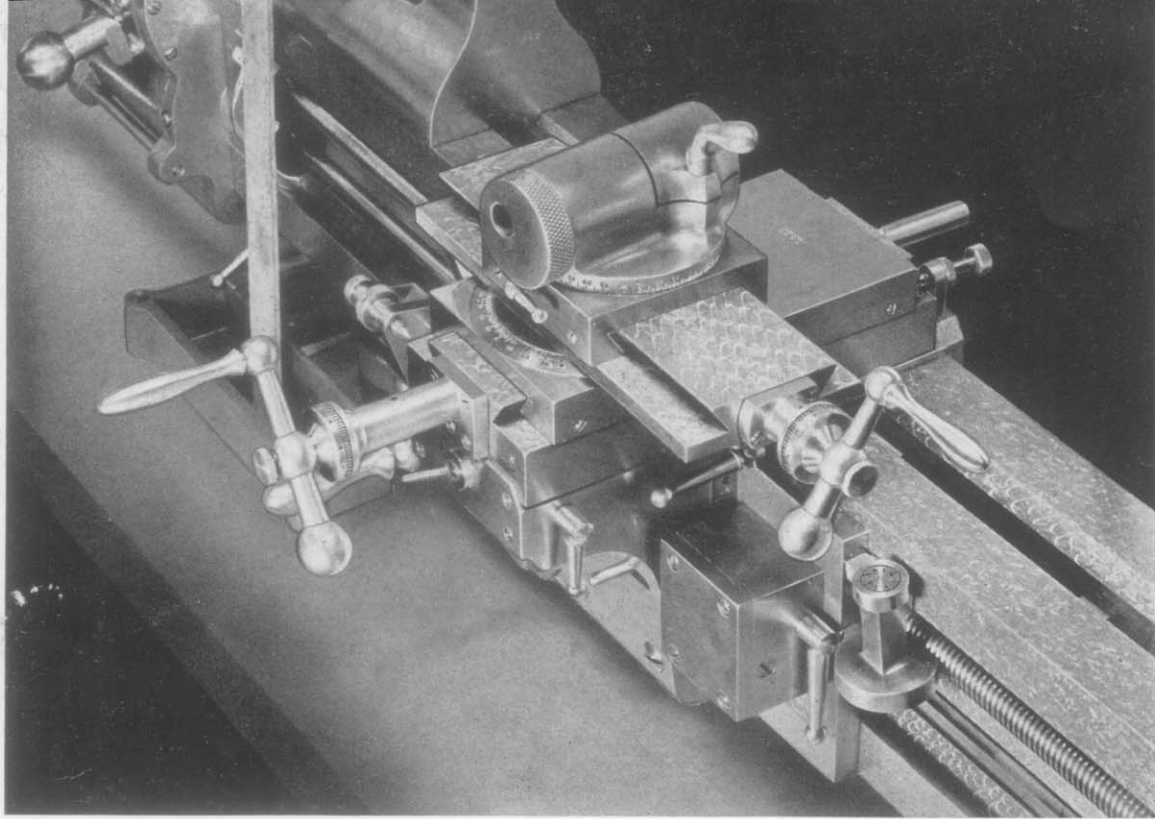

Fig. 6

COMPOUND SLIDE RESTS

The compound precision slide rest is furnished in two types, Eccentric Tool Holder, Fig. 6 and Rocker Tool Post, Fig. 8. Both types consist of a base, an upper and lower slide with a swivel between and feed screws to provide slide movements.

Either is removable as a whole from the lathe carriage to permit the use of dial gage, height gage, surface gage and other measuring and locating tools when setting-up and laying out work. With slide rest off, various attachments: the thread tool, Fig. 24, traverse miller, Fig. 31, plain tee rest, hinged tee rest, slotting and milling fixture, Fig. 40, and carriage milling attachment, Figs. 26, 27 and 28, may be mounted on the lathe carriage, in place of the slide rest.

All working surfaces are accurately scraped. Non-bearing surfaces are polished. Swivel movement is registered on a bevel-edged dial graduated in degrees over the full circumference. This swivel

is locked in any position by a convenient handle. Both slides are fitted with gibbs for adjustment, the top slide gib being at the front whereby the thrust in usual work is taken on the ungibbed surface.

An adjustable stop for the lower slide is provided for thread-cutting and for repetition of sizes in turning and grinding. Provision is made at front of base to locate this stop for internal threading and duplication of boring sizes.

Feed screws with Acme form of thread are of high carbon steel and work in long bronze nuts. Adjustments are provided to compensate for wear. Replacement after long periods of service is easily accomplished. Each feed screw is fitted with a large dial graduated to slide movement of .001". Dials may be rotated to any position on the feed screws and locked by knurled thumbscrews in the ball handles. When specified, slide rest feed screws of 2 m.m. (Metric) pitch with dials graduated to 0.02 m.m. are furnished.

Fig. 7



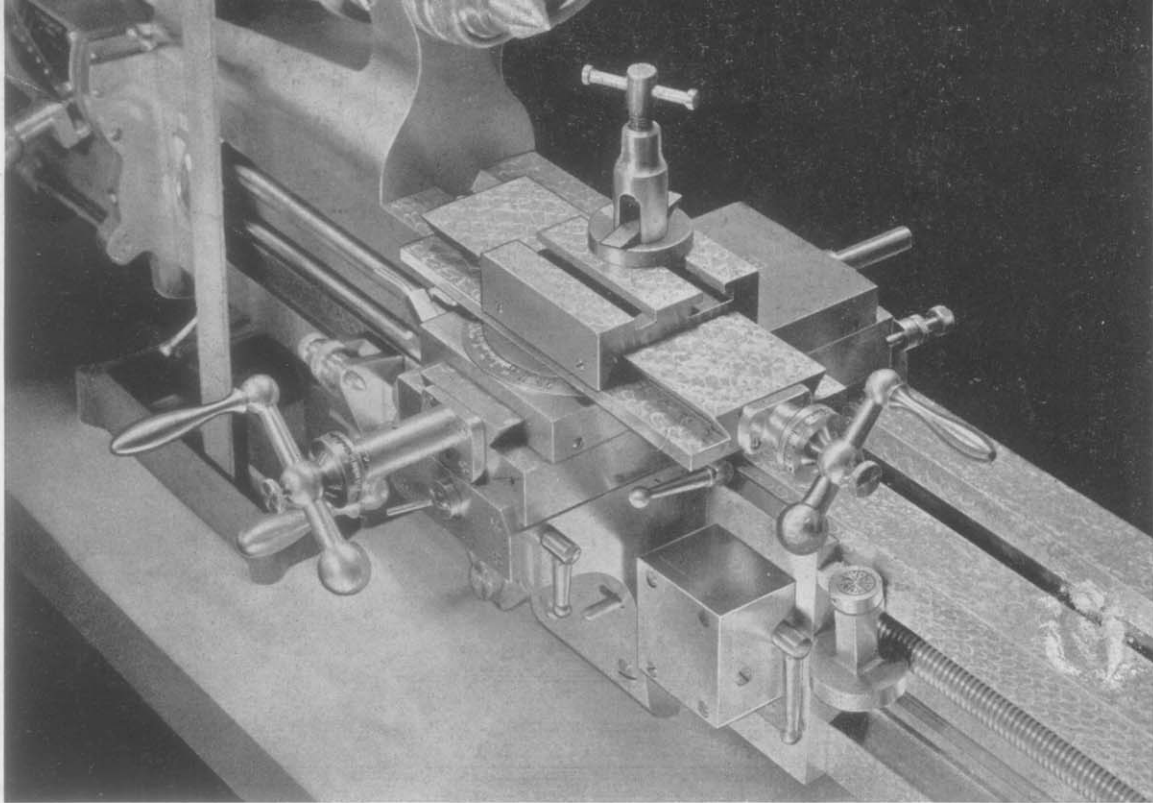

Fig. 8

Eccentric Tool Holder Type

With the eccentric tool holder slide rest, Fig. 6, the $\frac{1}{2}$ " round cutting tools are carried in an eccentric compressible holder with knurled end, Fig. 7. Rotation of the holder in the top swivel adjusts the height of the tool, and rotation of the tool in the holder gives proper rake and clearance angle settings. A binder handle clamps the holder and tool firmly in a graduated top swivel which swings to any angle on the top slide as indicated by the degree graduations on the full circumference of its lower rim. A binder handle clamps the top swivel to its slide.

The eccentric holder takes $\frac{1}{2}$ " dia. round tools with one or both ends properly shaped for various cuts. Round tools for internal threading, external threading, centering, right hand turning, cutting-off, boring, and knurling and a holder for internal threading tool, Fig. 7, are available. Forged tool holders with upper and lower edges turned to $\frac{1}{2}$ " dia. may also be used. A bar holder for $\frac{5}{16}$ " square tool bits, Fig. 7, also mounts in top swivel. A special eccentric holder, Fig. 7, with $\frac{3}{4}$ " hole, fitted with a sleeve having knurled head on the rear end for adjustment takes $\frac{5}{16}$ " square tool bits.

The top swivel, $1\frac{3}{8}$ " bore, is also utilized to mount the internal grinding attachment, Fig. 18, external grinding attachment, Fig. 19, slide rest milling attachment spindle, Fig. 25, and vise (eccentric slide rest type), Fig. 41.

It is important to note that this eccentric tool holder slide rest (which is particularly suited for 608 lathe), must be used if slide rest milling attachment is to be included with the lathe attachments.

Rocker Tool Post Type

In the rocker tool post slide rest, Fig. 8, the tool post is of conventional design for use of tools made of rectangular stock or forged tool holders to carry square tool bits. The tool post has slot with maximum capacity of $\frac{1}{2}$ " x $\frac{3}{8}$ ". Tool post rocker gives height adjustment. Fig. 9 shows a set of four tool holders: straight, right and left hand offset and boring, and a knurling tool. With the tool post removed, the top slide, with two tee slots, is used for mounting unit motor grinding attachments, Fig. 16 and Fig. 17, internal grinding attachment, Fig. 20, external grinding attachment, Fig. 21, angle iron, Fig. 40, and vise (rocker tool post type), Fig. 41. The bases of 608 slide rests of either type are afforded extremely accurate mounting by their position on the large-area hand-scraped top surface and long bevel-edged guideways of the carriage saddle. Slide rest may instantly be locked in any transverse location for straight boring by power feed, taper turning or boring with taper attachment, Fig. 15, by power feed, and bevel turning by hand feed. For power cross feed, slide rest is located and locked flush with front of saddle, and the saddle cross feed gear is then meshed with the cross-feed-screw driving pinion.

Fig. 9

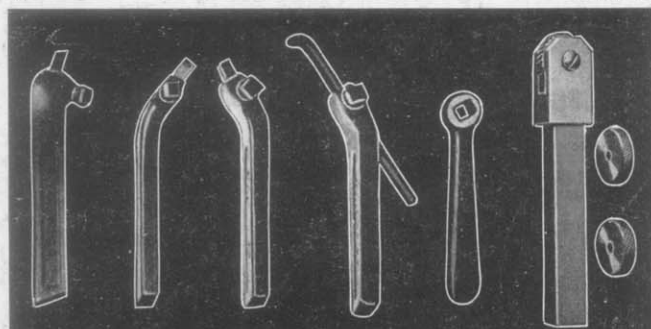

Set of Four Tool Holders

Knurling Tool

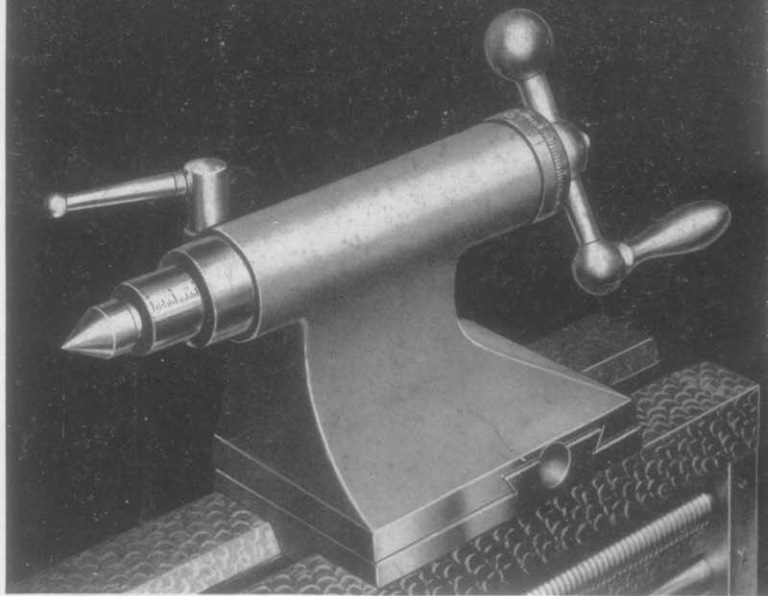

Fig. 10

TAILSTOCK

The tailstock, Fig. 10, is offset set-over type with hardened, ground and lapped spindle traversed by a high carbon steel screw working in a bronze nut, operated by a ball handle. Spindle movement is indicated on a graduated scale. Tailstock spindle has 3/4" maximum travel. For fine adjustment and duplication of setting, the spindle is fitted with a large adjustable dial graduated to furnish spindle movement of .001", Fig. 11. The dial is provided with a locking screw to permit easy resetting. The hole in the spindle is ground to Rivett special center taper gage, approximately 3° included angle. Center or other attachment is automatically ejected when spindle is fully retracted. A binder handle is provided for locking the spindle. A tailstock is scraped to correct alignment with the headstock and guideways and is clamped in any position by an eccentric binder and T-bolt fitting a slot in the bed. Tailstock equipment includes a hardened male center.

TURRET ATTACHMENT

The tailstock turret attachment, Fig. 12, is valuable for production of small duplicate parts. The turret

Fig. 12

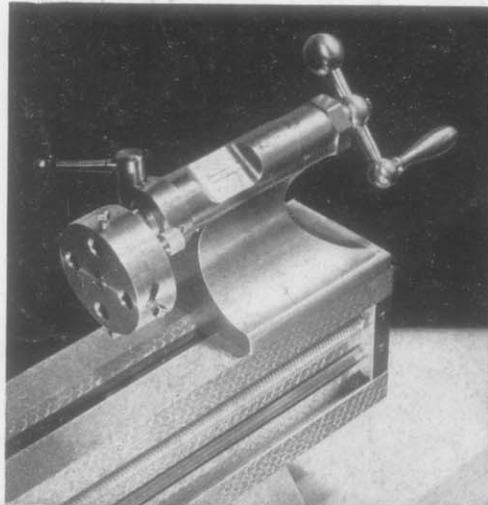

Fig. 13

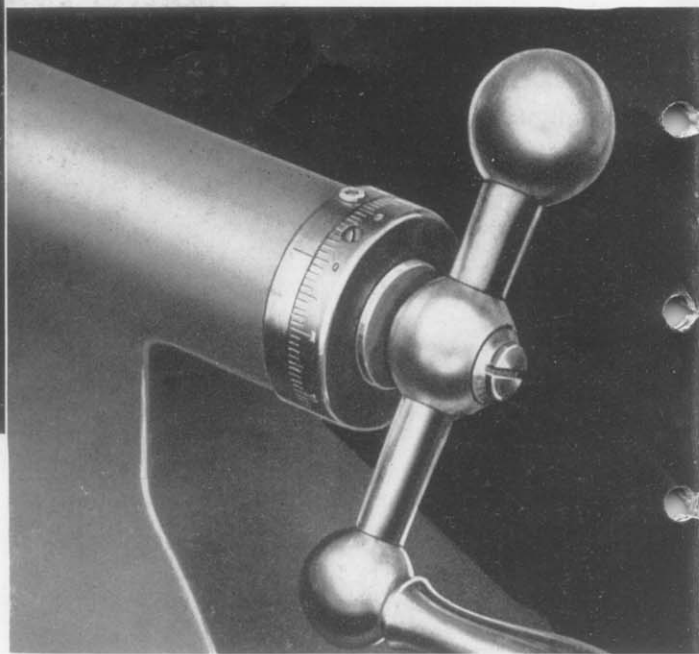
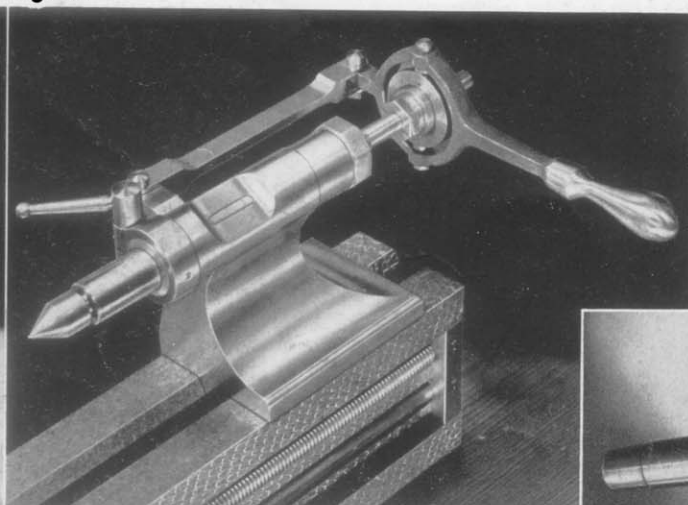

Fig. 11

head is rotated by hand and locked in position by index pin. The attachment is mounted by its tapered shank in the tailstock spindle.

LEVER ATTACHMENT

The tailstock lever attachment, Fig. 13, takes the place of ball handle for quick and sensitive traversing of tailstock spindle, when drilling, tapping, reaming or using tailstock turret attachment, Fig. 12.

KNURLING ATTACHMENT

The tailstock knurling attachment, Fig. 14, is used in production for diamond-knurling work held in collet. It mounts in tailstock spindle. The cross slide carrying the knurls is controlled by feed screw. Capacity 3/16" to 5/8" diameter.

Fig. 14

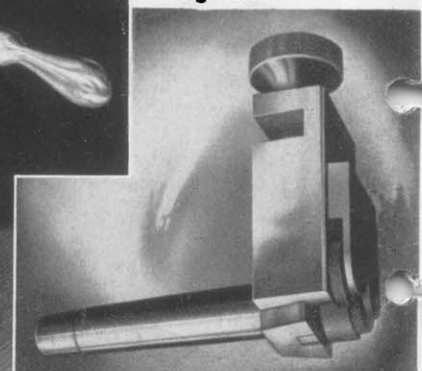

TAPER ATTACHMENT

The taper attachment, Fig. 15, is extremely valuable for taper turning and boring with power feed. It affords the only means for accurate cutting of taper threads. The back of the 608 lathe bed has a machined pad with two tapped holes. To this pad the guide bar bracket is permanently bolted and doweled. The connecting plate, or yoke, is detachably mounted on the rear end of the slide rest cross slide by screws and dowels. The dovetailed guide bar swivels and is graduated for setting to any angle up to 10° or up to 4" per foot taper, in either direction. Tapered work up to 13" long may be turned or threaded. In use, the guide bar is set to the required angle, the cross slide feed screw nut is released, by removing its retaining screw, immediately back of large graduated dial, and the slide rest compound is set at 50° or more to permit feed of tool for depth of cut.

Taper attachment constitutes an important part of a complete screw cutting lathe equipment and if

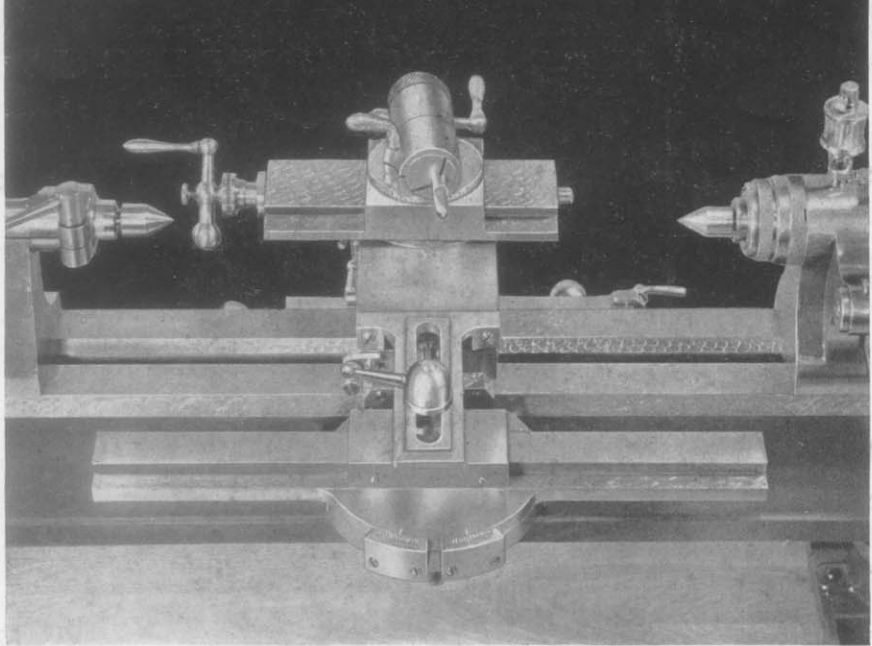

Fig. 15

taper work will ever be required, should be included with original order as for convenient and accurate mounting a special assembly fixture is needed.

Turning or threading tapers by setting over tail-stock or by use of off-center should be avoided as this practice ruins the work centers for subsequent operations, and in threading produces drunken threads.

UNIT MOTOR DRIVE GRINDING ATTACHMENT

The unit motor drive grinding attachment can mount on rocker tool post slide rest only, Fig. 8, and consists of $\frac{1}{5}$ H.P. universal motor driving ball bearing spindle between 6900 and 30,000 r.p.m. The grinder will finish internally, a hole $\frac{1}{8}$ " diameter or larger, Fig. 16, or will swing a 2" diameter wheel on external work, Fig. 17. The attachment is furnished with three interchangeable pulleys to obtain the

Fig. 16

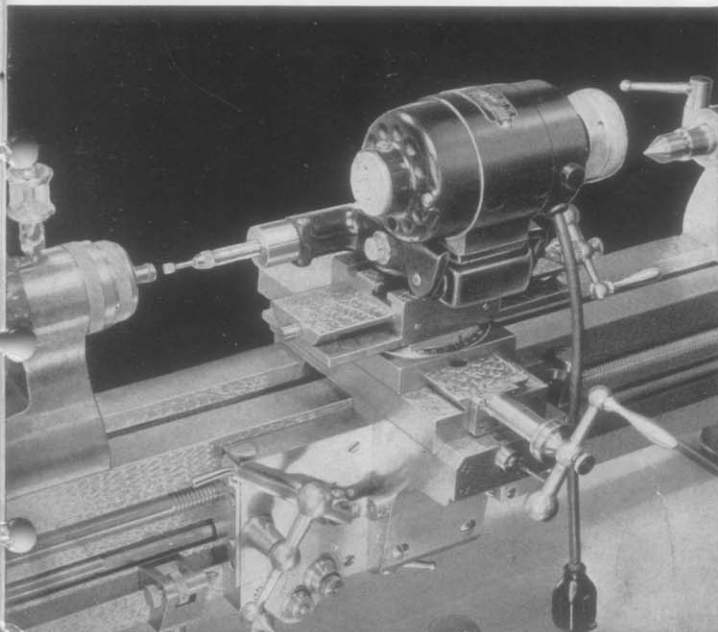

necessary wheel speeds for internal and external grinding. Equipment includes $\frac{1}{8}$ " collet type chuck for mounted wheels, two plain wheels 2" x $\frac{1}{4}$ " x $\frac{1}{4}$ ", 1 $\frac{1}{4}$ " x $\frac{1}{4}$ " x $\frac{1}{4}$ ", three mounted wheels $\frac{3}{4}$ " x $\frac{1}{4}$ ", $\frac{1}{2}$ " x $\frac{1}{4}$ ", $\frac{1}{4}$ " x $\frac{1}{4}$ ", motor cord and switch and case. The motor operates on 110-115 A.C. or D.C. current and may be furnished for 220-230 A.C. or D.C. The motor drive eliminates the necessity of countershaft.

Fig. 17

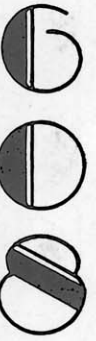
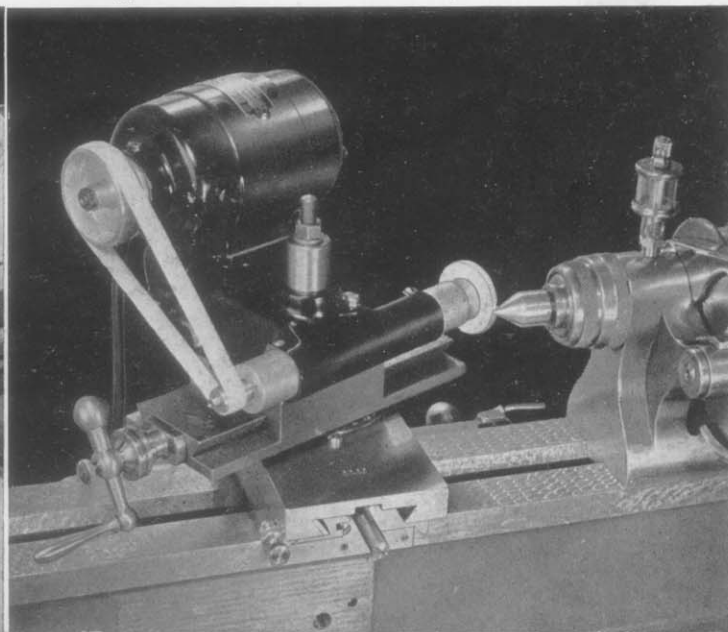

BELT-DRIVEN GRINDING ATTACHMENTS

RIVETT

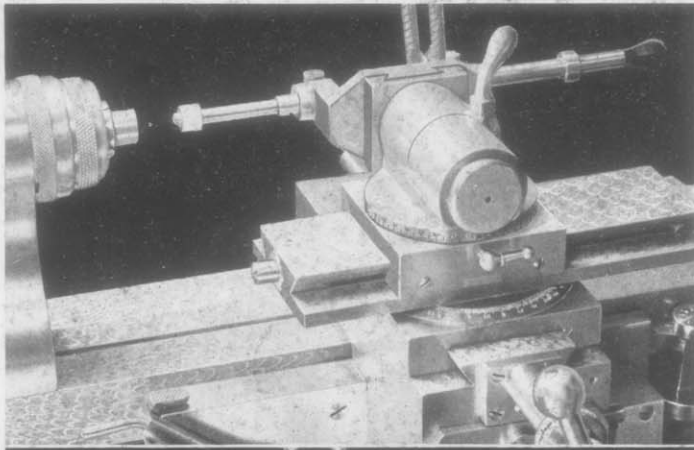

Fig. 18

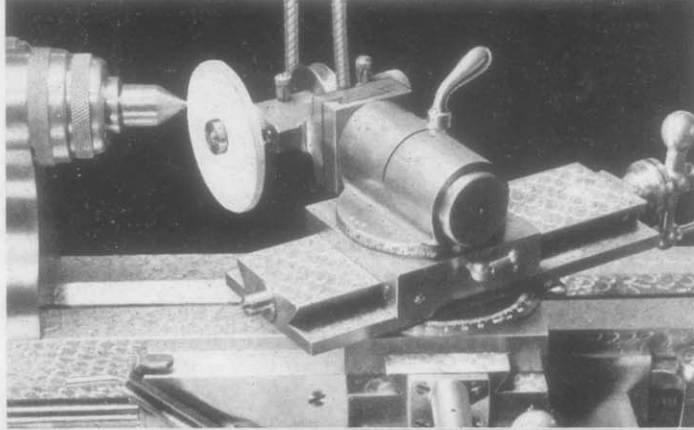

Fig. 19

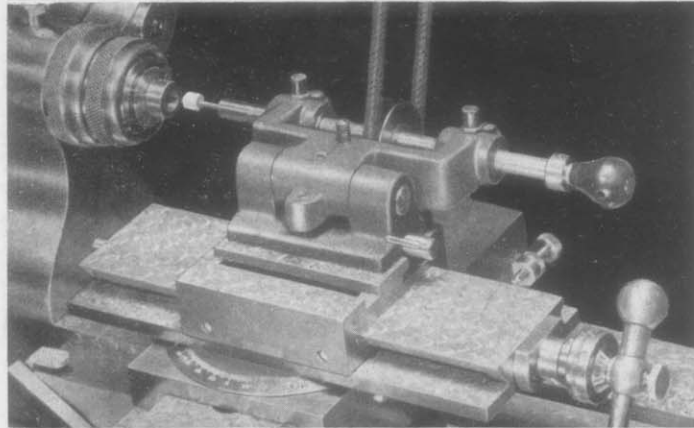

Fig. 20

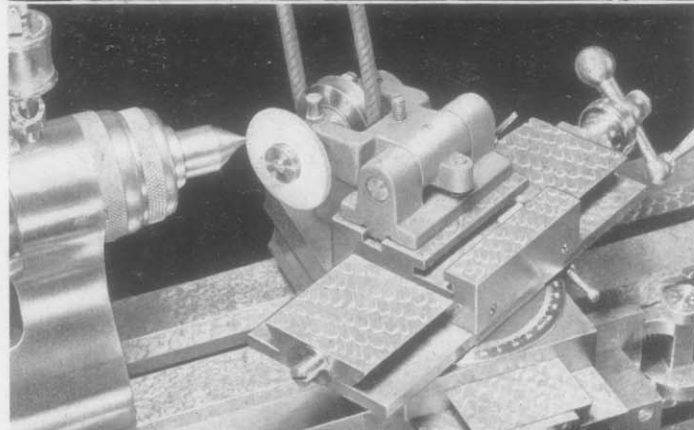

Fig. 21

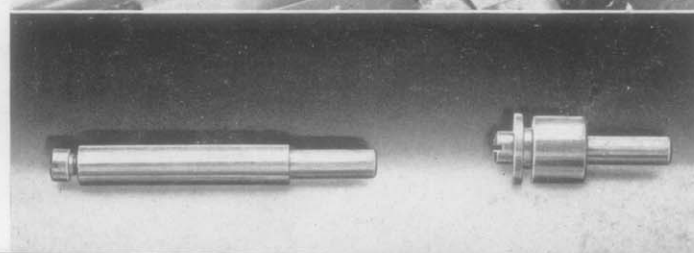

Fig. 22

Internal Type

The internal grinding attachment is used for grinding or lapping straight and taper holes, and high speed drilling with tools held in drill chuck. It is furnished for eccentric slide rest, Fig. 18, and for rocker tool post slide rest, Fig. 20. Heat-treated spindle runs in hard bronze bearings carried in bracket with height adjustment. Bearings have take-up for wear. Spindle has No. 4 P. & W. taper hole for insertion of wheel mount, wheel arbors, Fig. 22, and drill chuck, and is driven by round belt from auxiliary countershaft attachments, Fig. 45 or Fig. 51, at standard spindle speeds of 1100, 2500, 3600 and 8000 r.p.m., or from overhead attachment motor drive, Fig. 49. Cross, longitudinal and angular feeds are by slide rest feed screws. Grinding stroke of 2" is by hand.

External Type

The external grinding attachment is for finishing straight or taper work. It is furnished for eccentric slide rest, Fig. 19, and for rocker tool post slide rest, Fig. 21. Spindle runs in hard bronze bearings carried in bracket with height adjustment. Bearings have endwise and radial take-up for wear. Grinding wheel is mounted directly on the spindle and is held by a collar, flange and screw. Spindle takes wheels with $\frac{3}{8}$ " hole, up to 3" diameter x $\frac{1}{4}$ " face. The spindle is driven by round belt from auxiliary countershaft attachments, Fig. 45 or Fig. 51, at standard spindle speeds of 850, 1900, 2700 and 6000 r.p.m., or from overhead attachment motor drive, Fig. 49. Cross, longitudinal and angular feeds are by slide rest feed screws.

Internal Wheel Arbors

Grinding wheel arbors, Fig. 22, mount in spindle of internal grinding attachments. Two arbors, one each $\frac{1}{8}$ " x $\frac{1}{2}$ " and $\frac{1}{2}$ " x $\frac{7}{16}$ " are furnished with attachment. Five other intermediate sizes are available.

BALL TURNING REST

The ball turning rest, Fig. 23, will accurately generate spherical surfaces, concave and convex, and is extremely useful for turning various tools such as ball reamers, cutters, punches, and dies, forging dies and similar parts. Balled valve seats and discs, knuckles, universal and swing joints, knobs, hemispherical ends and a great variety of similar work may be quickly machined.

Ball turning rest is mounted directly on the bed and is easily attached, adjusted and removed. It is heavily built with large slides and ample area of swivel bearing surface. The lower slide has transverse screws for centering. The slide has a tee slot for location of tool post. The feed screw with knurled knob accurately adjusts the cutting tool position to give required radius of cut. It is equipped with an adjustable dial graduated to 0.001" which may be rotated to any position and

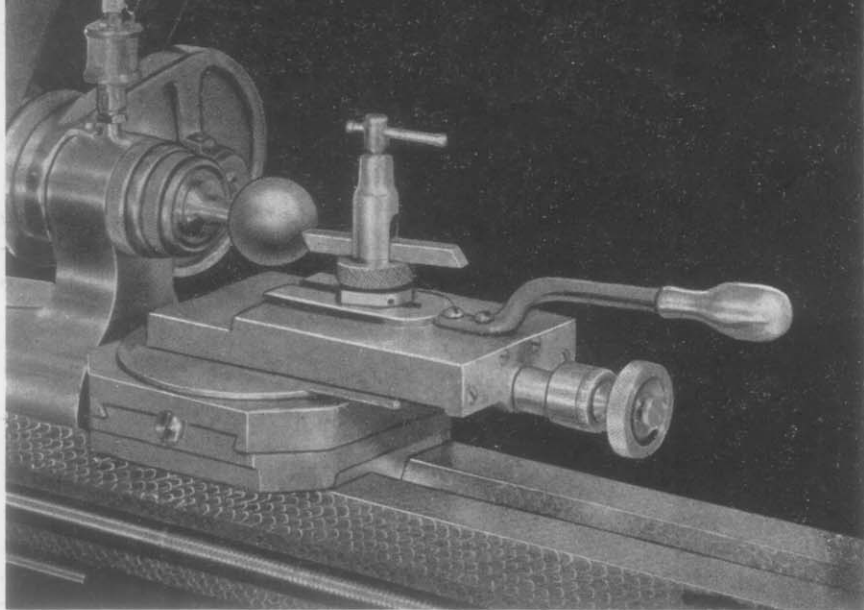

Fig. 23

locked by knurled thumbscrew, for duplication of pieces. The lever handle is operated to feed the tool over the work.

The tool post has adjustment for height of cutting tool. Maximum diameter that can be turned, limited by swing over the slide, is 3".

THREAD TOOL

The thread tool, Fig. 24, takes the place of single point tools generally used for cutting external threads in engine lathes. Its base is mounted on the carriage saddle of the lathe by means of a raising block to bring the center of the tool to prescribed height in reference to the lathe centers.

A hand lever and ratchet movement indexes the cutter one tooth for each travel over the work and a fine screw adjustment controls the final depth of cut to produce and duplicate pitch diameter of finished thread.

The cutter is a disc of carbon or high speed tool steel with ten teeth. The first tooth is widely topped and cuts only a very shallow groove or channel in the work, the second tooth cuts a little deeper but no wider and each tooth progressively deepens the groove until the ninth tooth which cuts almost to the full depth and width. The tenth tooth takes a very light finishing chip all over the thread and cuts to exact form and smooth finish.

The operator simply indexes the tool one notch for each reversal of the lathe. The progressive development of the thread in cuts of even increments is all accomplished by the form and indexing of the cutter and the waste of time due to taking light chips and the danger of tearing due to heavy chips are eliminated.

Cutters are furnished for threads of 6 pitch and finer and for many forms including: V, U.S., Acme 29°, Whitworth, International and Brown & Sharpe Worm Thread.

The cutter teeth are exactly to form and may be ground on the face until about one-eighth inch thick without sacrifice of strength or accuracy.

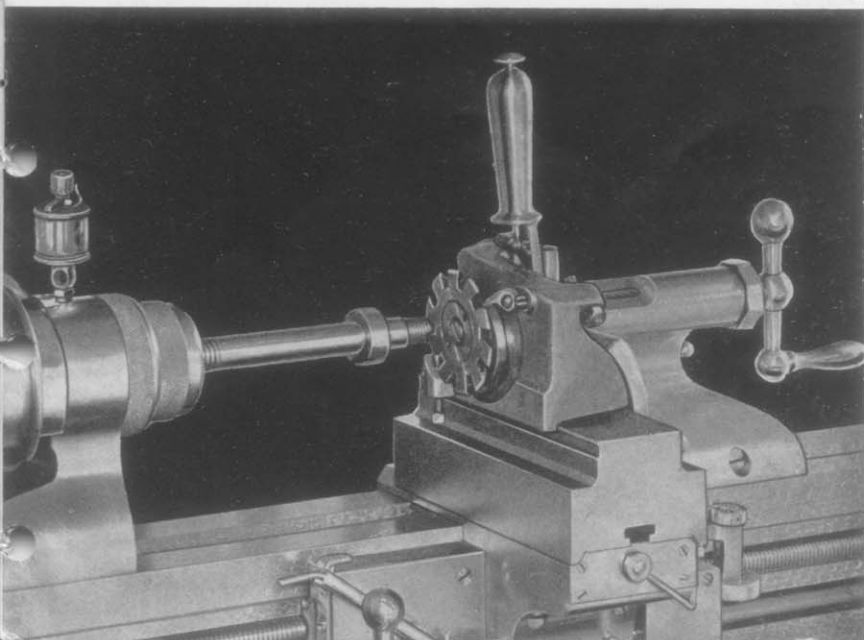
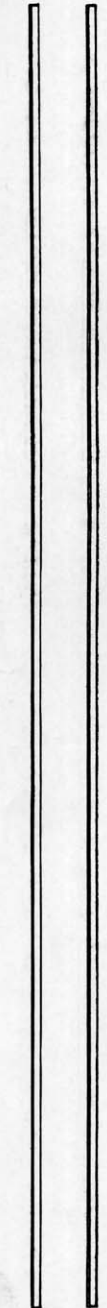
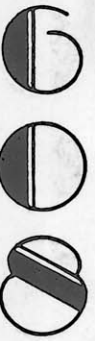

Fig. 24



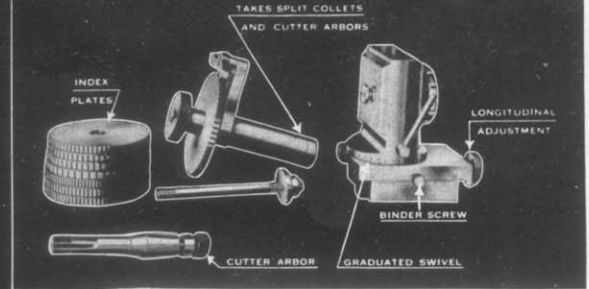
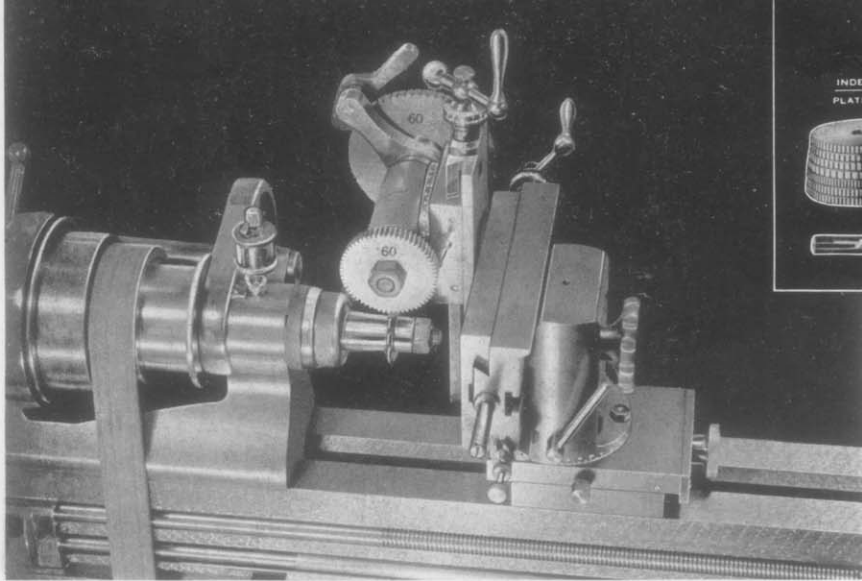

Fig. 25

SLIDE REST MILLING ATTACHMENT

This attachment, suitable for light milling operations, employs eccentric slide rest of lathe, Fig. 6, and is set up as in Fig. 25. Base, clamped to the lathe bed, carries a longitudinal slide, adjustable by feed screw with binder, and a swivably-mounted, vertical-faced head graduated to 90° each way from center and locked by binder handle. On this head is mounted the slide rest, clamped in any transverse

position. Spindle for 4 N.S. collets, with index plate on rear, is held in slide rest top swivel. Cutters are mounted on arbors drawn into lathe spindle. Graduated swivel on head and two slide rest swivels give universal adjustment. Slide rest feed screws with dials permit feeding in any direction. The vise for eccentric slide rest, Page 19, mounts directly in spindle, or with its sleeve, in top swivel of slide rest. Eight index plates divide the work. Movement of head on base, $1\frac{1}{8}$ "; slide rest lower slide movement $4\frac{1}{2}$ "; slide rest upper slide movement $5\frac{1}{2}$ ".

CARRIAGE MILLING ATTACHMENT

This attachment is a complete unit of substantial design and wide capacity range having vertical travel $4\frac{3}{4}$ ", longitudinal hand feed travel $2\frac{7}{16}$ " and power or hand cross feed of $8\frac{1}{16}$ ". When used with 608 lathe it is equivalent to a universal milling machine. It mounts on saddle in place of slide rest. Longitudinal power feed is by carriage travel. Power cross feed is from cross feed gear in carriage. Universal movements in three directions are by three feed screws and ball handles fitted with adjustable dials graduated to .001". Base is fitted with transverse slide carrying swivel, graduated over full circumference, on which mounts the upper slide carrying vertical-faced knee. Swivel is locked by eccentric binder. Knee is fitted with a vertically-fed slide having three tee slots providing a large area for positioning top swivel in which mounts the spindle. Graduated top swivel swings to any position, and carries spindle for 4 N.S. or 5 C collets, or vise, Page 19. Index plates mount on rear of spindle. Fig. 26 illustrates operation of milling teeth of a beveled gear, cutter carried on arbor in lathe spindle. Fig. 27 shows work clamped by tee slot to vertical slide, with taper-shank cutter and center chuck in lathe spindle for milling a dovetail. Fig. 28 demonstrates jig boring operation using straight-shank adjustable boring tool and collet in lathe spindle. Spacing of jig holes is by transverse and vertical screws with graduated dials. Feed may be by hand, using longitudinal screw, or by power travel of carriage.

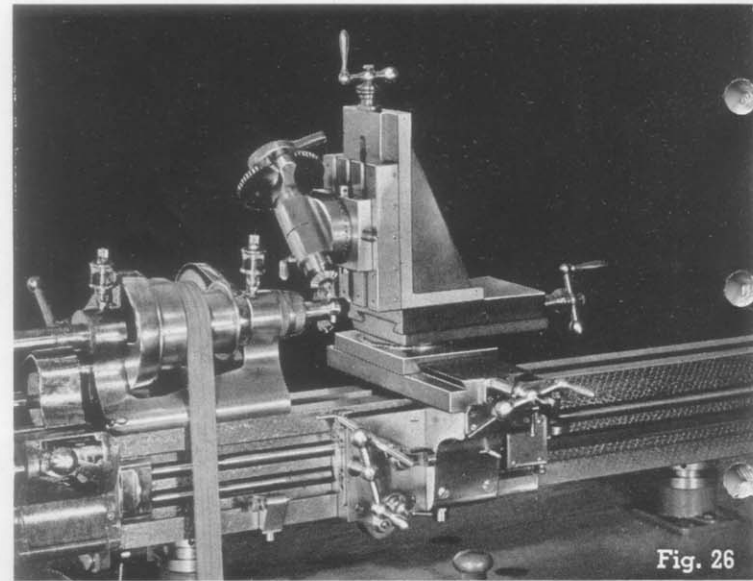

Fig. 26

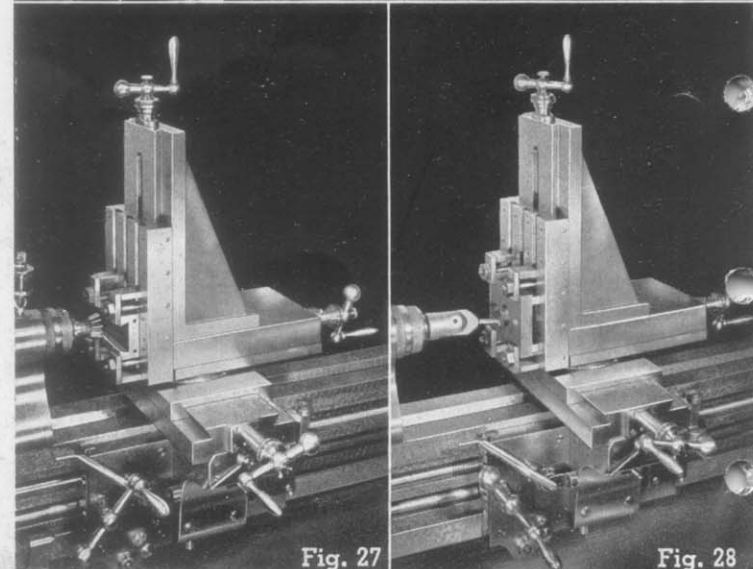

Fig. 27

Fig. 28

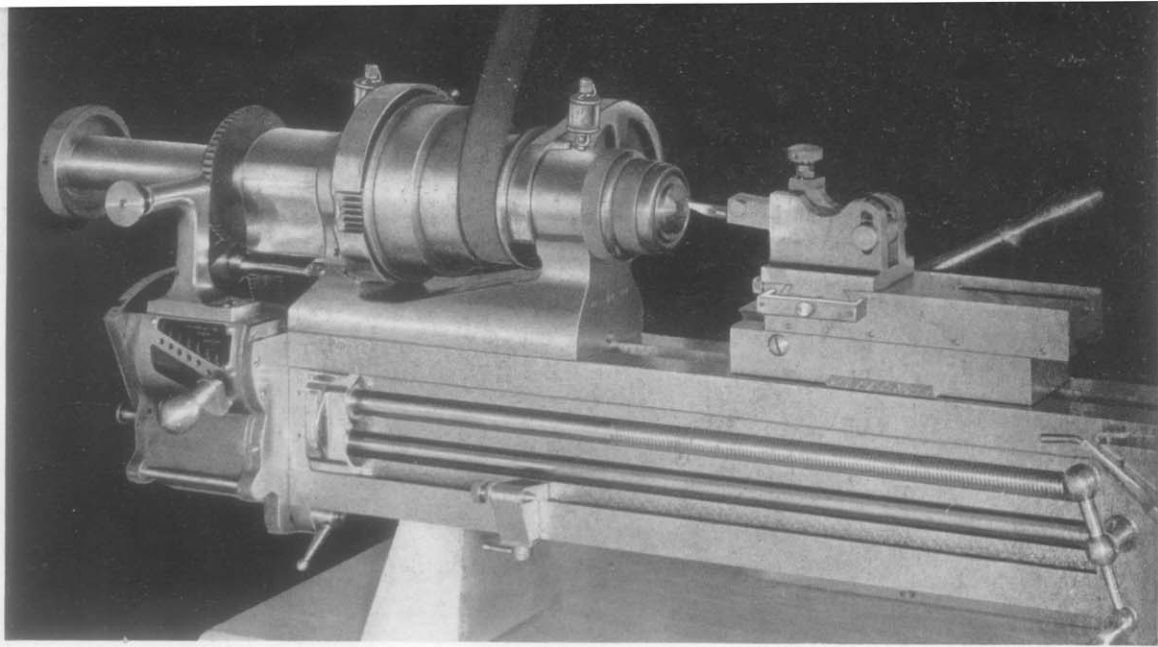

Fig. 29

SLOTING ATTACHMENT

The slotting attachment, Fig. 29, mounts on the base of the cutting-off and forming slide which is set parallel with the lathe bed on an adapting shoe. The tool is manually operated for cutting keyways, slots and holes of odd contour. By using indexing attachment, square, hexagon and other regular shaped holes can be produced.

It is often convenient to use slotting attachment for making accurate square and hexagon hole collets from soft blanks, to be subsequently slit, and heat treated, as broaching cannot be relied upon to produce true-running holes.

The attachment consists of a tool block with

holder for $\frac{5}{16}$ " round tool bits. The tool block has screw-controlled transverse feed up to $1\frac{1}{8}$ " while the tool holder has vertical screw adjustment or feed of $1\frac{1}{8}$ " and a secondary adjustment for setting proper cutting rake. The tool may be reciprocated $3\frac{1}{2}$ " by a hand lever rack and pinion movement in cutting-off and forming slide base.

SPECIFICATIONS

Width of base	3"
Length of base	9"
Width of slide	3"
Length of slide	9"
Travel of slide	$3\frac{1}{2}$ "

INDEXING ATTACHMENT

The indexing attachment, Fig. 30, divides or indexes work held in the headstock spindle of the lathe. An index plate is mounted at the rear end of the lathe spindle and clamped by the draw-in spindle.

If lathe is equipped with lever chuck closer, Page 4, it is necessary to have a plain screw draw-in spindle for use with this attachment, since index

plates cannot be mounted on lever chuck closer draw-in spindle.

A bracket with index pin is bolted to the change gear yoke, Fig. 30, or to the top surface of the quick change gear box housing, Fig. 29.

Index plates with 45, 56, 60, 64, 72, 80, 84 and 100 divisions are standard and carried in stock. Plates with other divisions may be furnished to order.

Index plates furnished with slide rest milling attachment and carriage milling attachment, Page 12, can interchangeably be used as above for indexing.

It is highly important when selecting attachments for 608 lathe to consider their interrelation. For example, the slotting attachment cannot be used for many of its proper functions without also employing indexing attachment.

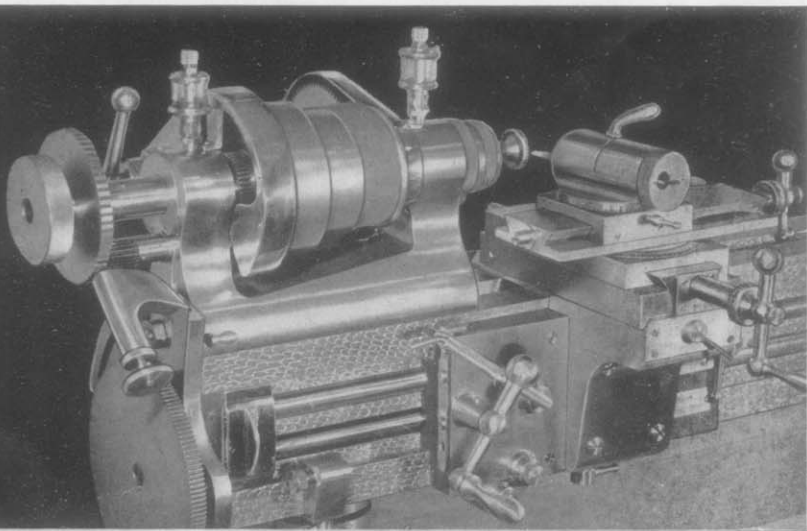

Fig. 30

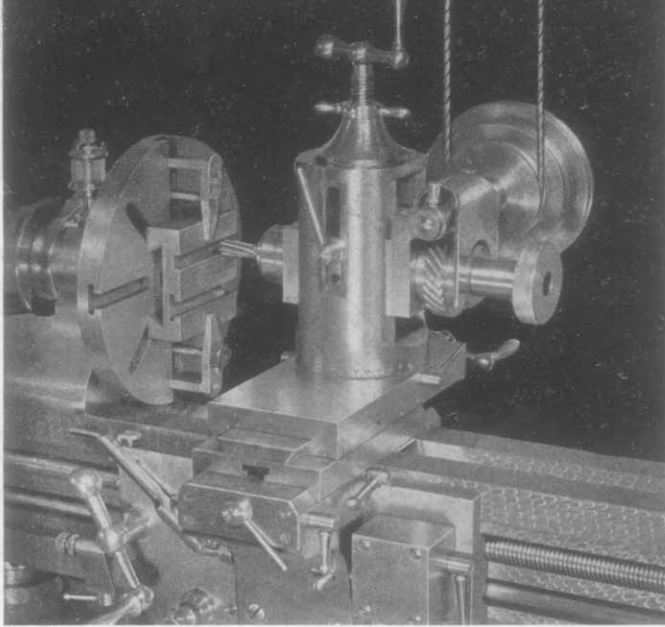

Fig. 31

TRAVERSE MILLER AND ATTACHMENTS

The traverse miller, Fig. 31, is for work on lathe centers or held on face plate. Combined with the spiral attachment, Fig. 33, spiral milling and fluting operations may be accomplished. With the addition of thread milling attachment, Fig. 32, screws, worms, hobs and similar work through a wide range of pitches and thread forms can be quickly milled to a

high degree of accuracy and smooth finish. With the traverse grinder, Fig. 34, work may be ground following a milling operation and subsequent heat treatment.

The traverse miller mounts on the carriage saddle in place of the slide rest and is fed longitudinally by the feed rod or lead screw. Transverse adjustment and movement are by the cross feed screw, with dial graduated to 0.001". The column carrying the cutter spindle may be swiveled to any desired angle. Base is graduated 90° each way from center and locked by two binder handles. Spindle has a vertical adjustment of 2 $\frac{3}{8}$ " in the column. An adjustable set collar permits feeding to definite depth on duplicate work. A handle on side of column binds the spindle slide in any vertical position. Spindle is designed to carry cutter arbors having shanks same as Rivett No. 4 N.S. collets, tightened by draw-in spindle. By the use of collets, milling cutters or other tools with shanks up to $\frac{5}{8}$ " diameter may be held. Arbors for cutters with holes up to 1" diameter are carried in stock. The traverse miller is driven from auxiliary countershaft attachments, Figs. 45 or 51, or from overhead attachment motor drive, Fig. 49, by a round belt through spiral gear to its spindle. The weighted auxiliary idler pulley maintains proper belt tension assuring adequate drive for the attachment at any of its speeds and when swiveled to any position. Twelve spindle speeds from 150 to 1750 r.p.m. are available.

Thread Milling Attachment

This attachment, Fig. 32, is used with the traverse miller for machining screws, worms, hobs and similar work through a wide range of pitches and thread forms. The round belt feed drive, which is part of the spiral attachment equipment, Fig. 33, and a speed-reducing device are required to drive the lathe spindle and lead screw, through change gearing, at proper relative speeds to mill the desired pitches.

The attachment is mounted on the traverse miller. The cutter can be accurately set to a dial graduated in degrees to correspond with the helix angle of the thread to be milled. Cutter is driven by traverse miller spindle through spiral gears to cutter arbor. Arbor takes cutters with $\frac{3}{4}$ " hole. Twelve cutter speeds from 90 to 1200 r.p.m. are available.

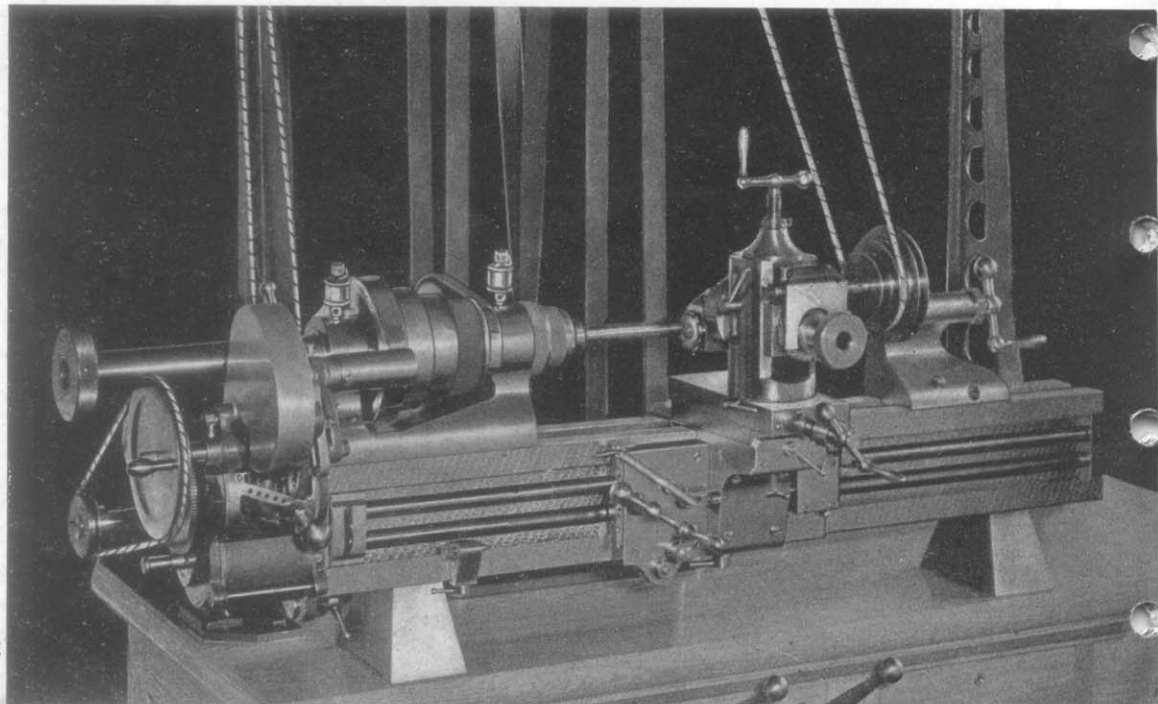

Fig. 32

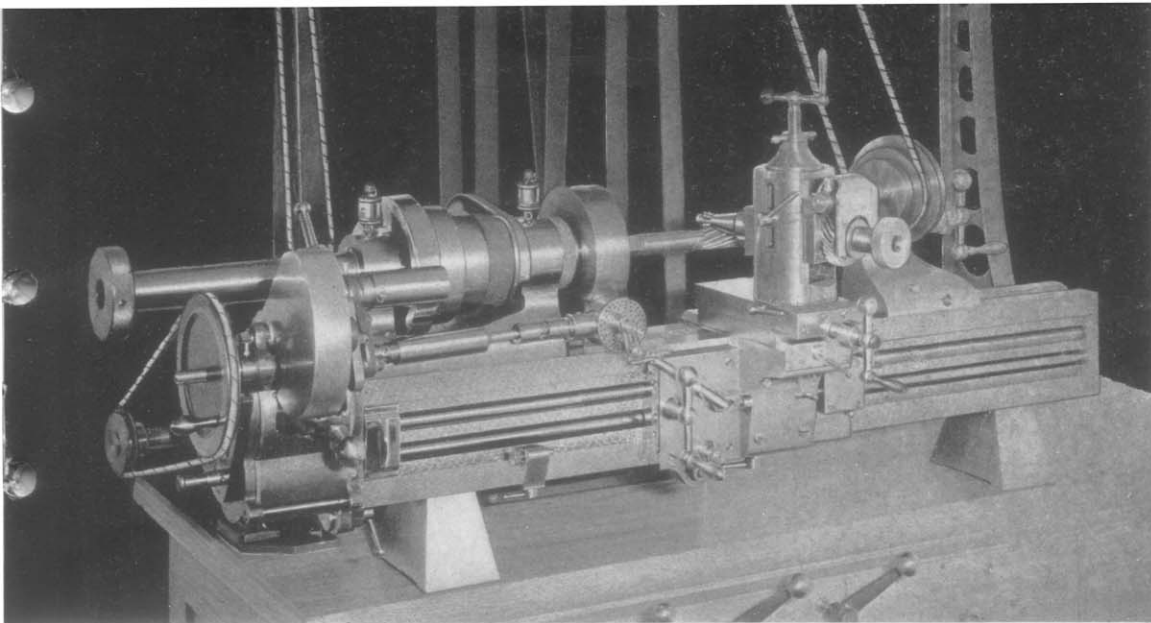

Fig. 33

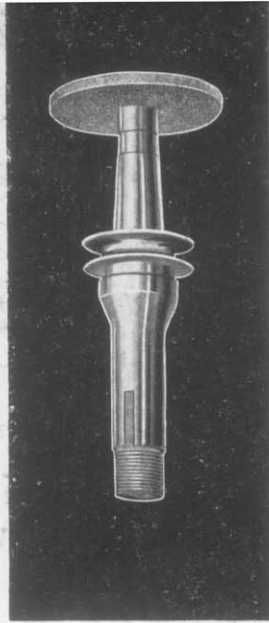
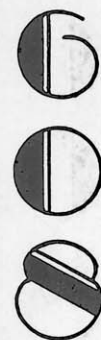

Fig. 34

RIVETT



Spiral Attachment

The spiral attachment, Fig. 33, is used with the traverse miller for cutting flutes and other spiral grooves, and slots. A dividing head with an adjustable indexing crank is interposed in the transmission. Two perforated index plates provide for cutting desired number of teeth or flutes. The attachment is

driven by round belt through a pedestal-type countershaft mounted on bench or cabinet top in rear of lathe head. A crank handle is provided for setting up the work. The dividing head and lead screw are driven with change gear lathe as shown in Fig. 35, or with gear box lathe as shown in Fig. 33.

Traverse Grinder

This attachment, Fig. 34, is used with the traverse miller for grinding work following milling operation and subsequent heat treatment. The grinding attachment is mounted in the spindle of the traverse miller

and is driven directly from auxiliary overhead countershaft attachment as seen in Fig. 35. Standard spindle speeds are 850, 1800, 2800 and 5700 r.p.m. Grinding wheels, $\frac{5}{16}$ " hole, $\frac{1}{4}$ " face are used.

RELIEVING ATTACHMENT

The relieving attachment, Fig. 35, is used to relieve, or back-off, right or left hand taps, milling cutters, counterbores and similar tools having straight or spiral flutes. It is mounted on carriage saddle in place of slide rest. The tool slide swivels and can be swung to any angle as indicated by graduated dial up to 90° each side of center. By proper setting, the teeth of angular and straight-face tools can be relieved. The tool slide throw is controlled by cam with adjustment up to $\frac{1}{16}$ " maximum. The tool block takes tools or tool holders with $\frac{1}{2}$ " square shanks.

The drive is from overhead countershaft by round belt through a pedestal-type countershaft mounted on bench or cabinet top in rear of lathe head. A crank handle on the driven pulley is provided for setting up work. The lead screw and the telescopic shaft are driven with change gear lathe as shown in Fig. 35 and with gear box lathe as shown in Fig. 33. Attachment can relieve up to twenty flutes with change gear lathe and thirty flutes with gear box lathe.

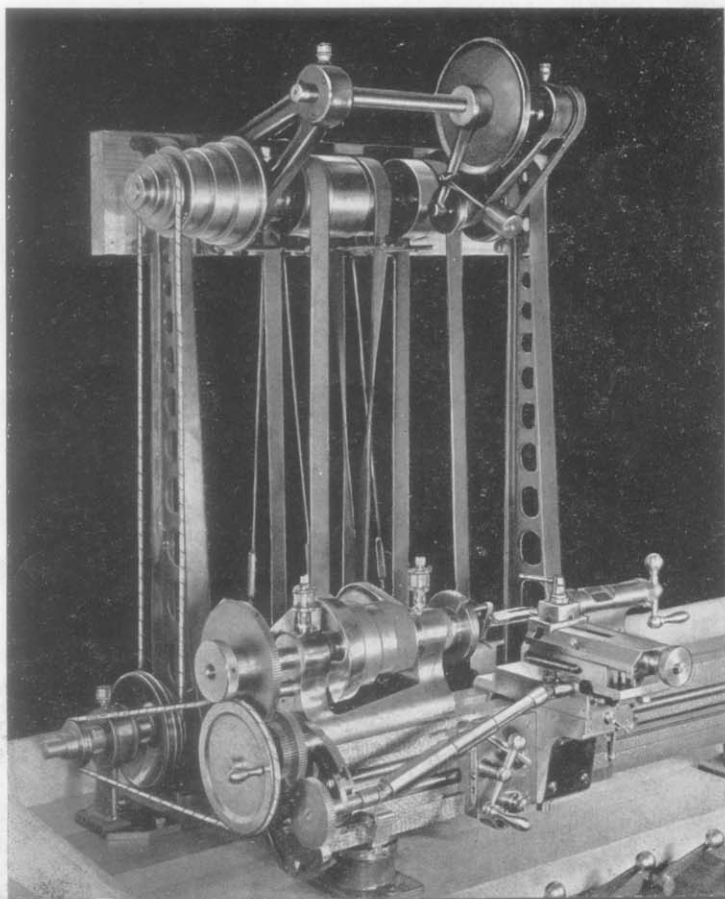

Fig. 35

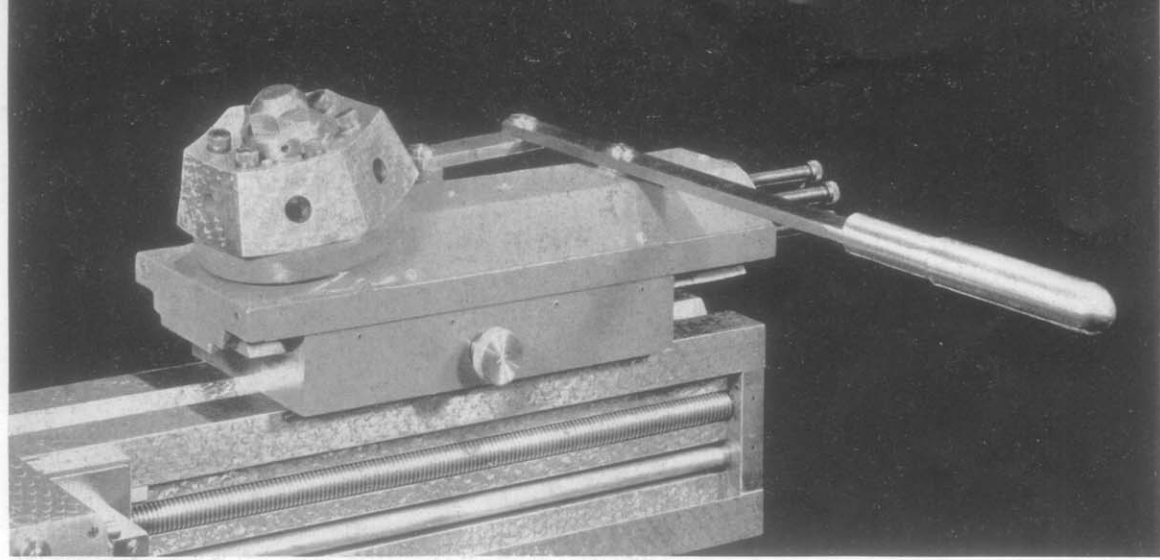
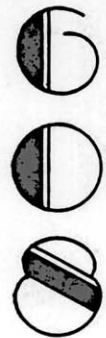

Fig. 36

AUTOMATIC INDEXING TURRET

A 608 lathe equipped with automatic indexing turret attachment, Fig. 36, cutting-off and forming slide, Fig. 38, or cutting-off and turning slide, Fig. 39, and lever chuck closer as in Figs. 3 or 4 is an efficient, high precision hand screw machine. For production of steel parts, oil pan and oil pump and piping, Page 24, should be used in combination.

The turret head has six stations for holding turret tools with $\frac{3}{4}$ " diameter shanks as shown in Fig. 37. The head is carried on slide, dovetailed and gibbed to base which is mounted in any position on

the lathe bed and fastened by two studs. The slide is operated by hand lever. Turret automatically indexes with the slide movement. Head is self locking in operating position.

Six independently adjustable stops are geared to and automatically index with the turret head.

SPECIFICATIONS

Length of base	9 $\frac{5}{8}$ "
Travel of slide, maximum	3 $\frac{3}{4}$ "
Number of tool holes in head	6
Diameter and depth of tool holes	$\frac{3}{4}$ " x 1"

Fig. 37

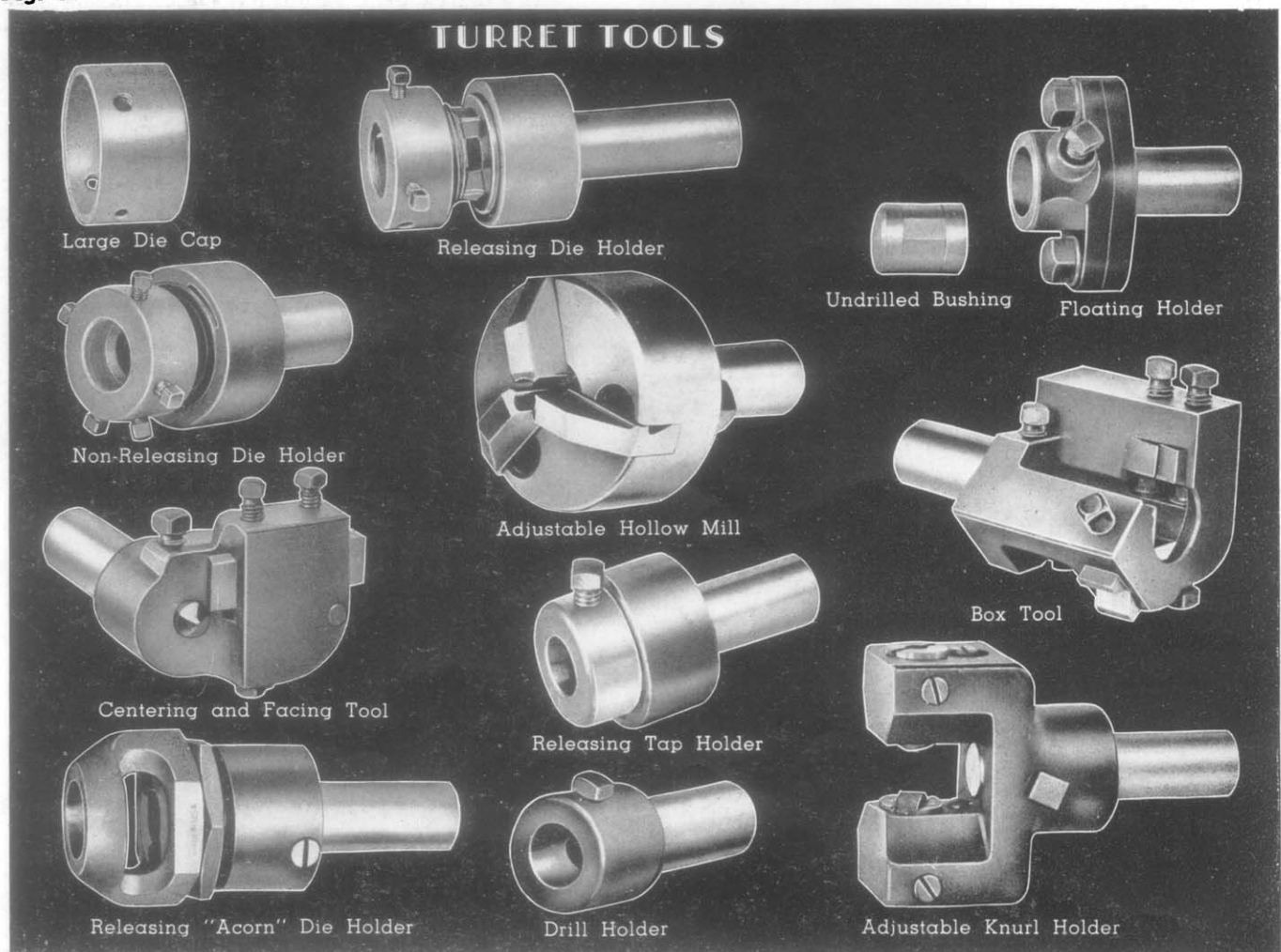

CUTTING-OFF AND FORMING SLIDE

This attachment, Fig. 38, mounts two tools for forming plain or irregular shapes to close diameter limits and for rapid cutting off. The base is mounted on a beveled shoe scraped to alignment with the bed. A cross slide is dovetailed and gibbed to the base and is traversed by a rack, pinion and handle movement giving ample power and close control for feeding the tools. A cutting-off blade is carried in a substantial tool block at the rear of the slide and a circular forming tool in a holder at the front. An annealed circular forming tool blank, $\frac{3}{4}$ " wide, is included. The tool block at the rear is clamped to a slot giving transverse location adjustment of 2". The forming tool holder is mounted in a gibbed dovetail affording $1\frac{1}{4}$ " longitudinal adjustment.

An adjustable stop, mounted on the rear of the base, controls the cross slide travel for duplication of sizes.

A rear tool holder as shown in Fig. 39 may be substituted, if preferred, for the cutting-off tool block.

SPECIFICATIONS

Width of base	3"
Length of base	9"
Travel of cross slide	$3\frac{1}{2}$ "
Diameter of circular forming tool	$1\frac{11}{16}$ "
Maximum width of circular forming tool	$\frac{3}{4}$ "
Size of cutting-off blade	$\frac{3}{32}$ " x $\frac{1}{2}$ "
Swing over cross slide	$3\frac{1}{8}$ "

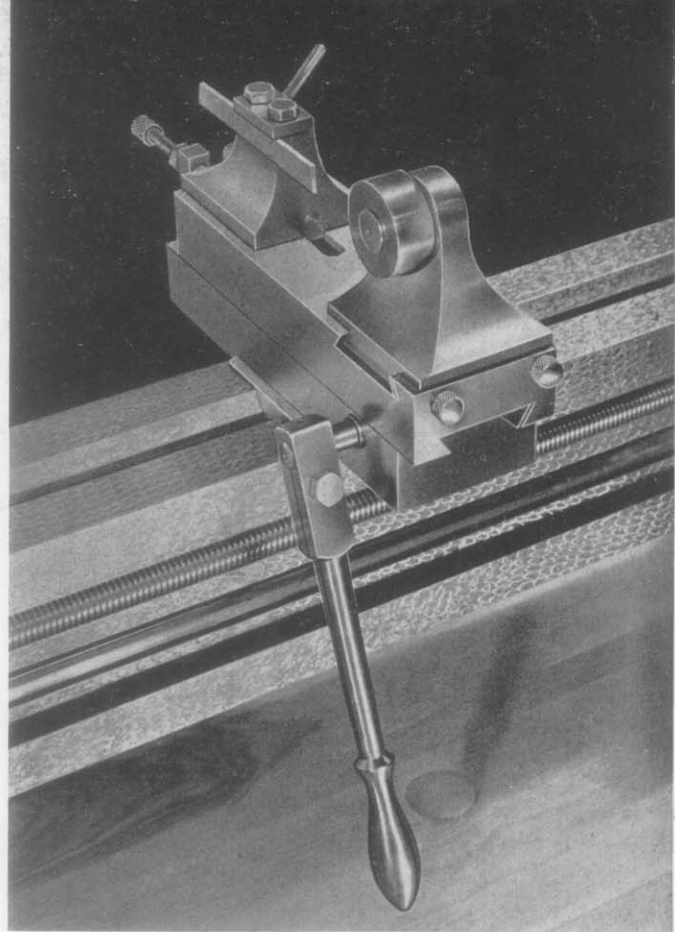

Fig. 38

CUTTING-OFF AND TURNING SLIDE

The cutting-off and turning slide, Fig. 39, provides for mounting two tools. It is used for straight turning to close limits and for rapid cutting off, generally in connection with the turret attachment, but will independently finish pieces of simple form. The base is mounted on a beveled shoe scraped to alignment with the bed and is held by a stud, washer and nut. A cross slide is dovetailed and gibbed to the base and is traversed by a rack, pinion and handle movement giving ample power and close control for transverse movement. A block with tool post is mounted on the rear of the slide in a slot providing location latitude of 2".

The front of the slide has a longitudinal dovetailed guideway with a slide fitted with a rocker tool post for $\frac{3}{8}$ " square tool bits or $\frac{5}{16}$ " x $\frac{1}{2}$ " tool holder. Rack, pinion and handle movement traverses the tool for turning operations.

A single stop at the rear of the base and a two-way stop at the front control all tool movements, for duplication of sizes.

SPECIFICATIONS

Width of base	3"
Length of base	9"
Travel of cross slide	$2\frac{1}{4}$ "
Travel of front tool slide	$1\frac{1}{2}$ "
Swing over cross slide	$3\frac{1}{8}$ "

Fig. 39

RIVETT

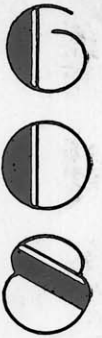

PAGE

ATTACHMENTS

RIVETT



FOLLOWER REST attaches to base of slide rest. Used to support work held on centers. Brass jaws have adjustable capacity to 3" diameter.

HINGED STEADY REST mounts on lathe bed. Hinge permits removal of work without moving jaws. Three brass jaws with screw adjustment and locking screws. Max. capacity 4" diameter.

PLAIN STEADY REST mounts on lathe bed. Three adjustable brass jaws with locking bolts. Max. capacity 3" diameter.

PLAIN TEE REST base mounts on saddle in place of slide rest. Standard tee 3". Base also used for 6" tee, triangle, el rest and saw table.

HINGED TEE REST mounts on saddle. Swings away from work when not in use. Base also used for 6" tee, triangle, el rest and saw table.

SLOTING AND MILLING FIXTURE mounts on saddle. Vee block, adjustable for height, carries square holder for 4 N. S. collets. Work, held in collet, advanced against saw or cutter on arbor held in lathe spindle. Depth of cut, controlled by adjustable stop nuts, max. 1".

SIX INCH TEE mounts in tee rest base. Convenient for hand tooling long work.

TRIANGLE REST mounts in tee rest base. Used for slitting, sawing and grinding. Vee-groove locates and holds round work. Length of sides 4 1/8".

EL REST mounts in tee rest base. Used for hand-tooling in narrow grooves and corners and truing work held in jaw chuck.

SAW TABLE mounts in tee rest base. Used for supporting work with saw or other tool mounted on arbor held in lathe spindle. Table 3" x 4".

CLAMP DOG, 3/4" capacity, used for clamping and driving work held between centers.

ANGLE IRON used on rocker tool post slide rest, slotted face plate and carriage milling attachment. Has tee slots uniform with slide rest, face plate and carriage milling attachment and vee grooves for round work. Length 4 1/4", width 3 1/4", height 3".

RESTS



Follower Rest

Hinged Steady Rest

Plain Steady Rest

Plain Tee Rest

Hinged Tee Rest

Slotting and Milling Fixture

6 Inch Tee

Triangle Rest

El Rest

Saw Table

Clamp Dog

Angle Iron

Fig. 40

ATTACHMENTS

RIVETT

FACE PLATES AND VISES

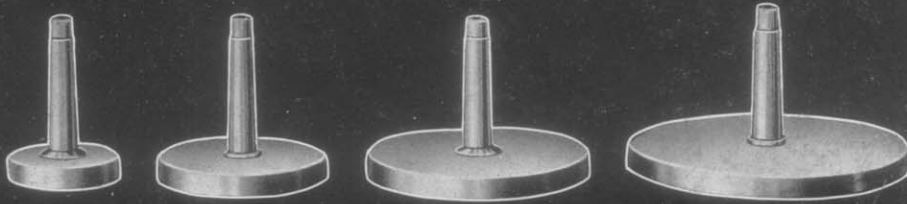

Drill Plates 2", 3", 4" and 5" Dia.

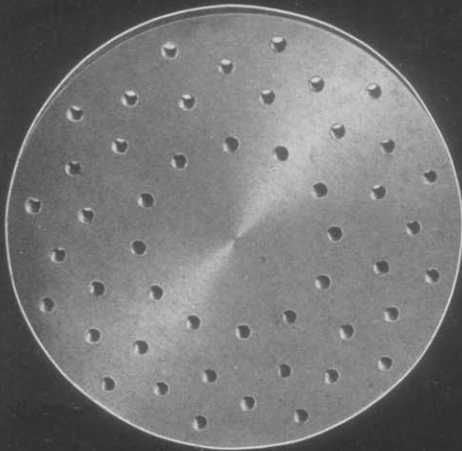

Tapped Face Plate



Emery Face Plate

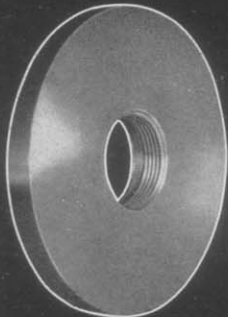

Plain Face Plate

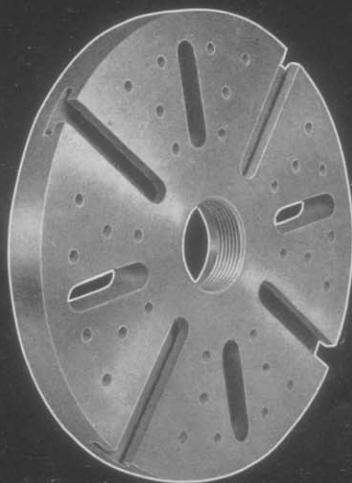

Slotted and Tapped Face Plate

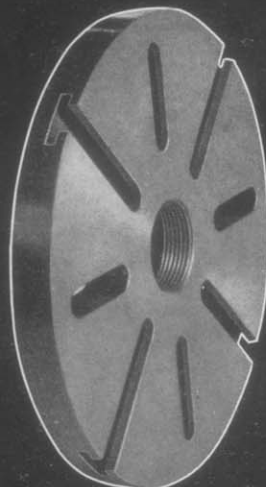

Slotted Face Plate

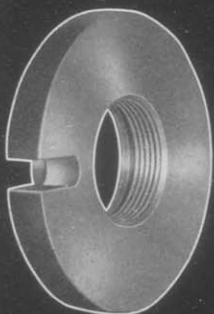

Driving Plate

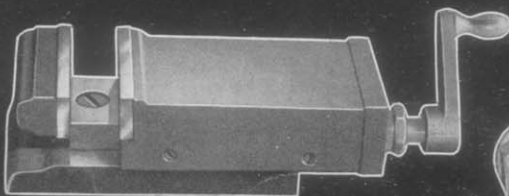

Vise for Rocker Tool Post Slide Rest

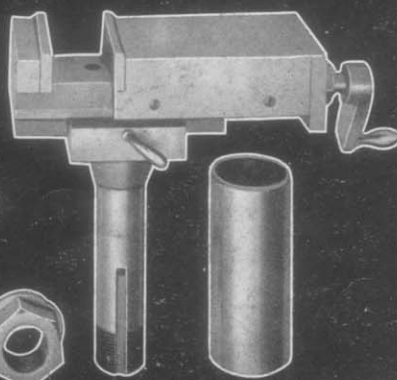

Vise for Eccentric Slide Rest

DRILL PLATES, 2", 3", 4" and 5" diameter, are mounted on steel shanks to fit both tailstock spindle and headstock center chuck. Plates are cast iron, shanks of steel accurately ground. They are used as back support for work with drill held in headstock spindle.

TAPPED FACE PLATE, 7" diameter, has forty-nine holes tapped $\frac{1}{4}$ "-20 N. C. for convenient strapping of work.

EMERY FACE PLATE, 7" diameter, has circular scoring for mounting emery discs.

PLAIN FACE PLATES, $4\frac{1}{4}$ " or $5\frac{1}{8}$ " diameter, mount on threaded spindle nose and are used for mounting chucks and special holding fixtures.

SLOTTED FACE PLATE, 8" diameter, has four plain slots and four tee slots for fastening work. Tee slots are same size as on top slide of rocker tool post slide rest, carriage milling attachment and angle iron.

SLOTTED AND TAPPED FACE PLATE, 8" diameter, has four plain slots and four tee slots, same as slotted face plate, and thirty-two holes tapped $\frac{1}{4}$ "-20 N. C.

DRIVING PLATE, $3\frac{3}{4}$ " diameter, has $\frac{3}{8}$ " wide notch to receive work drivers.

VISE FOR ROCKER TOOL POST SLIDE REST has tongued base for fitting in tee slots of top slide on rocker tool post slide rest, slotted face plate, angle iron and carriage milling attachment. Jaws are hardened steel with $1\frac{3}{4}$ " maximum opening.

VISE FOR ECCENTRIC SLIDE REST with shank mounts directly in headstock spindle or spindle of slide rest milling attachment or carriage milling attachment. With sleeve, it mounts in top swivel of eccentric slide rest. Jaws are hardened steel with $1\frac{1}{2}$ " maximum opening.



Fig. 41

ATTACHMENTS

RIVETT



BLANK CENTER of annealed tool steel, 1" diameter x 1 3/8" long, may be turned to any desired form. Taper shank fits center chuck and tailstock spindle.

HALF MALE CENTER has hard head slabbed off to provide clearance for turning tools when facing ends of work and for external grinding of small diameters.

MALE CENTER has head 2 3/32" diameter with 60° included angle and tapered shank for center chuck or tailstock spindle. Furnished hard for tailstock and soft for headstock.

FEMALE CENTER has hard head 2 3/32" diameter with 60° included external angle. The center hole has 3/16" max. diameter with 60° included internal angle.

SPUR CENTER has conical center-point and two knife edges. Used for wood turning.

SOLID V-CENTER has soft head 1 1/16" diameter and groove with 90° included angle 7/8" wide.

REVOLVABLE V-CENTER has soft head which turns freely on shank, accommodating itself to position of work.

LARGE MALE CENTER has hard head, 1 1/2" diameter with 60° included angle. Used for turning tubing or work with holes too large to run on standard centers.

ADJUSTABLE OFF-CENTER has 1/2" diameter hard male and female removable centers. Slide has screw adjustment allowing max. offset of 1/4".

CENTER AND CENTER CHUCK consists of soft male center with taper fit in center chuck. Solid center chuck fits headstock spindle.

CENTERS

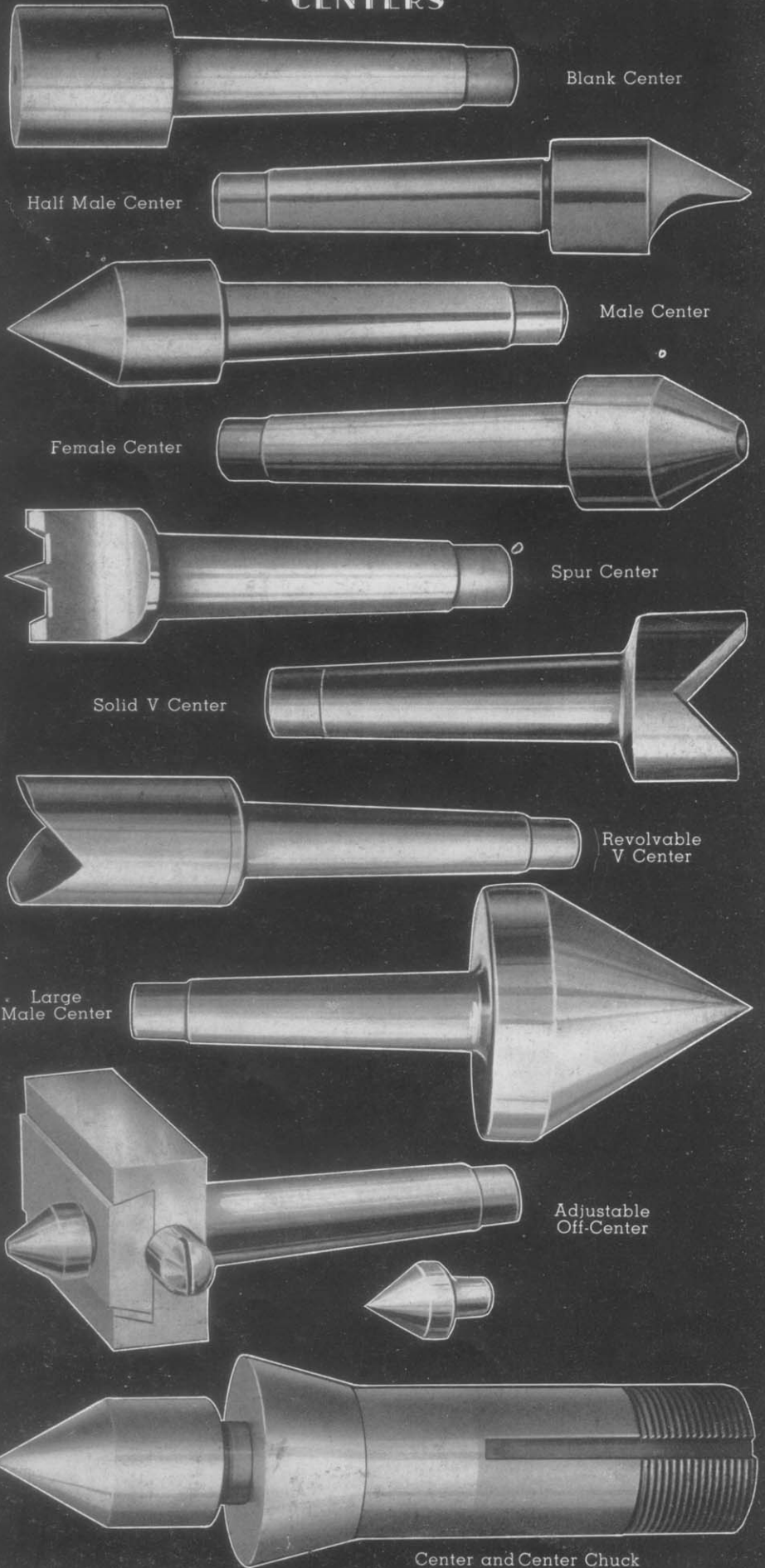

COLLETS AND CHUCKS

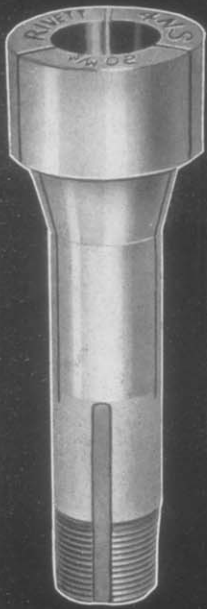

1" Step Chuck

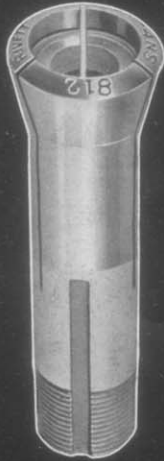

Pot Collet

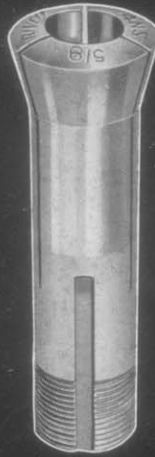

4 N.S. Collet

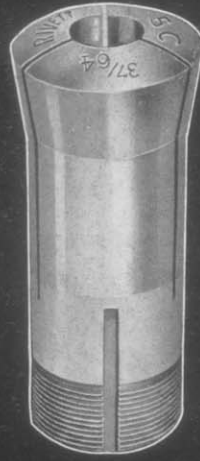

5 C. Collet

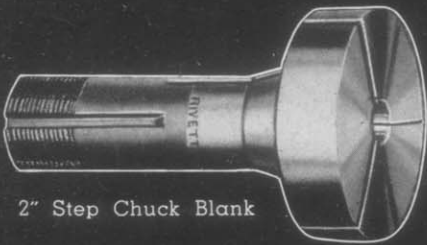

2" Step Chuck Blank

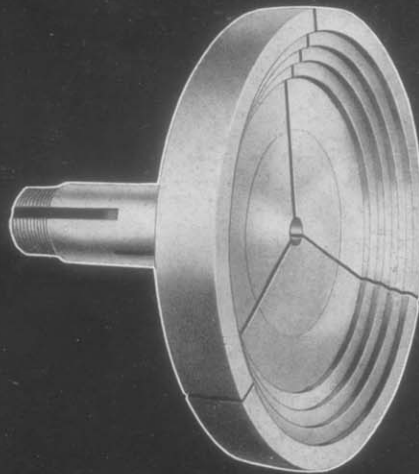

6" Step Chuck—Stepped

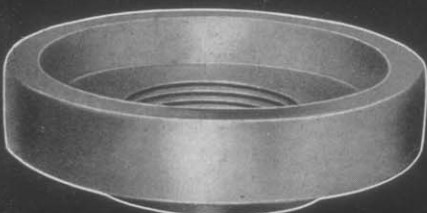

Step Chuck Closing Ring

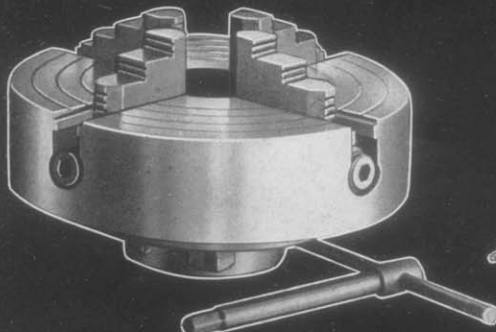

6" 4-Jaw Independent Chuck

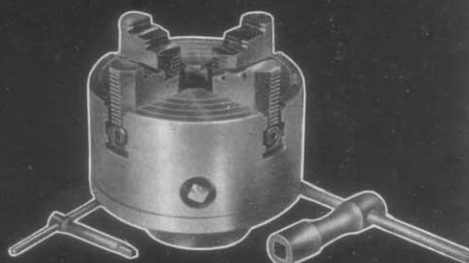

6" 4-Jaw Combination Chuck

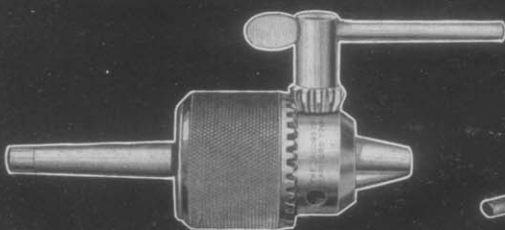

Drill Chuck

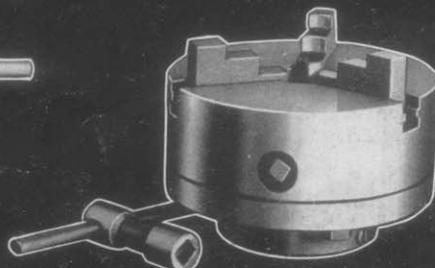

3-Jaw Universal Chuck

1" **STEP CHUCK**, 4 N. S., is split, spring-tempered and ground. Hole max. 1" diameter x $\frac{3}{4}$ " deep.

POT COLLETS, 4 N. S. or 5-C, are split, spring-tempered and ground. Max. diameter and depth of hole, limited by head dimensions: 4 N. S. = $2\frac{5}{32}$ " x $\frac{3}{16}$ "; 5-C = $1\frac{1}{16}$ " x $\frac{3}{16}$ ".

STANDARD COLLETS, 4 N. S. or 5-C are split, spring-tempered and ground. Holes are guaranteed to run dead true at mouth. Furnished in round holes $\frac{1}{64}$ " diameter to capacity in fractions, decimals or odd sizes. Sq. and hex. holes $\frac{1}{8}$ " to capacity. Taper hole collets are unsplit. Blanks are soft for finishing to special shapes. All collet threads are accurately cut to limit gages.

2" **STEP CHUCK BLANK**. Step chuck blanks 4 N. S. and 5-C, made from steel forgings, are furnished soft, split, with $\frac{3}{16}$ " hole, to be bored to desired diameters. Sizes 2", 3" and 4" in 4 N. S., and 2", 3", 4", 5" and 6" in 5-C. Either style in 2" closes by drawing into spindle mouth. Larger sizes require closing rings.

6" **STEP CHUCK—STEPPED**. Standard, 4 steps each $\frac{3}{32}$ " deep. Special steps as specified.

STEP CHUCK CLOSING RING, 4 N. S. or 5-C screws on threaded spindle nose and presents tapered closing surface for step chucks: either style 3" size takes 3" and 4" chucks, and 5" size takes 5" and 6" chucks.

6" **4-JAW INDEPENDENT CHUCK**, reversible jaws, iron body. Accurately fitted to chuck plate. Max. capacity $7\frac{1}{4}$ " diameter.

6" **4-JAW COMBINATION CHUCK**, geared scroll type, reversible jaws. Independent and universal movement. Accurately fitted to chuck plate. Max. capacity $7\frac{5}{8}$ " diameter.

3-JAW UNIVERSAL CHUCK, geared scroll type, inside and outside jaws. Accurately fitted to chuck plates.

DRILL CHUCK, taper shank for tail-stock, or headstock center chuck, or straight for collet or turret. Capacities: $\frac{1}{4}$ ", $\frac{3}{8}$ " and $\frac{1}{2}$ " diameter.

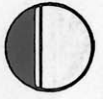

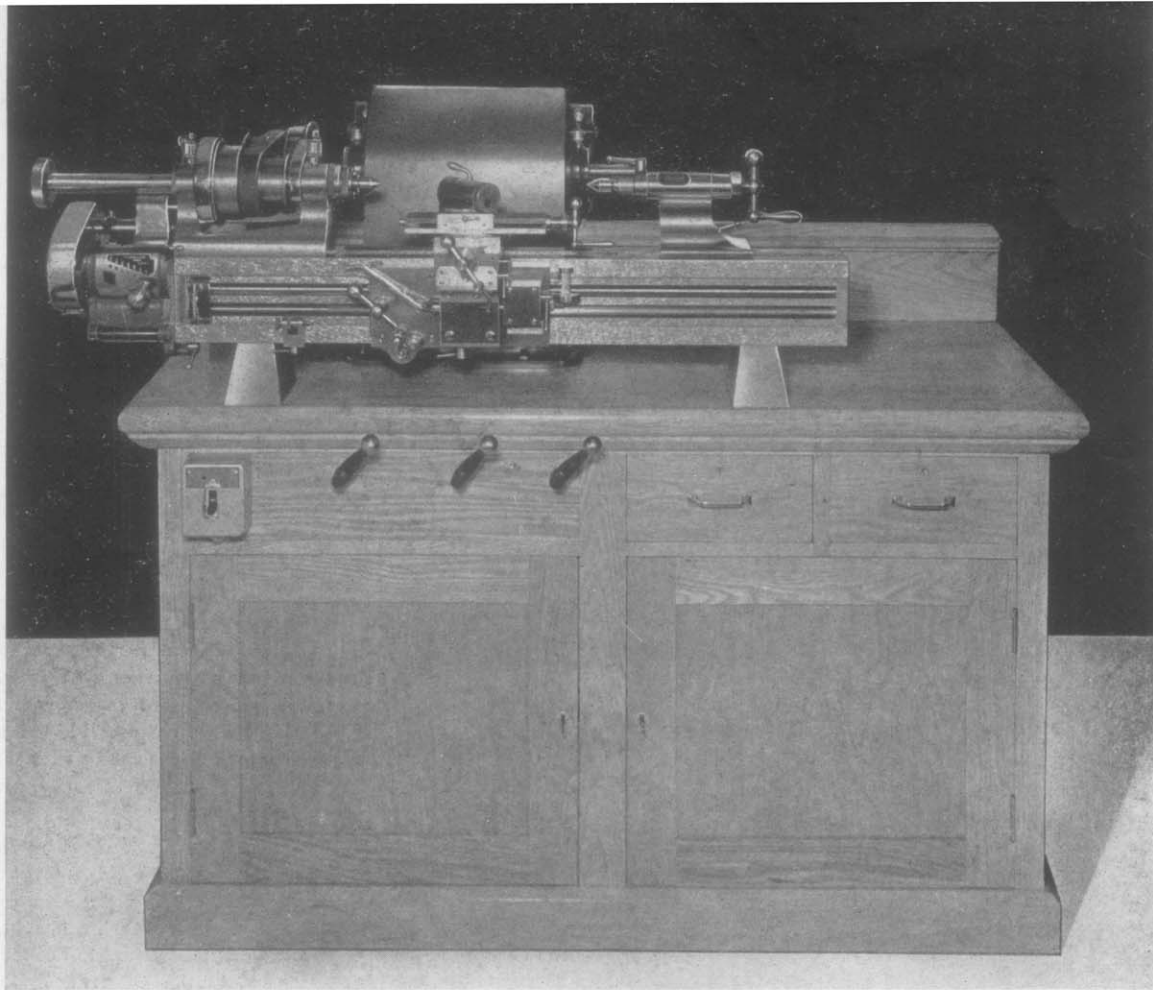

Fig. 44

HORIZONTAL SAFETY DRIVE ON CABINET

This drive is mounted in rear of lathe on cabinet, Fig. 44, or bench, Figs. 45 and 57. Overhead countershaft and belting are eliminated. No light is cut off and a lathe thus driven is, on a unit bench or cabinet, a self-contained machine which may readily be installed wherever power is available. Spindle starts instantly and stops quickly,—important characteristics for bench lathe efficiency. The motor runs continuously. Reversal is by shift of crossed belt. Controls, for cabinet, are hand shifters, Fig. 44, or, for bench, either latch foot treadles, Fig. 45, or hand belt shifters, as illustrated in Fig. 51, which start and stop lathe in high, low and reverse speeds.

All journals and loose pulleys are ball-bearing and all belts are endless, the whole constituting a quiet and vibrationless drive which will run for years without maintenance expense.

Standard motor, 1750 r.p.m., is located inside the cabinet or on bottom plank of bench. To produce 12 spindle speeds HS-1, Figs. 45 and 57, motor is fitted with a single sheave and V-belt driving underneath jackshaft which is mounted on back plank of cabinet or bench. For 24 spindle speeds HS-6, see Page 31, 2-step sheaves and 1165 r.p.m. motor are used.

The underneath jackshaft carries pulleys for three vertical belts. The opening for these belts is surrounded by a guard which pivotally supports the

countershaft base. By means of a stud and nut at the front of the guard the countershaft base is swung on its trunnions. This single movement brings the three vertical belts and the horizontal headstock belt into proper initial tension and is later used to tighten the belts to compensate for stretch in service. After adjustment is made, base is locked to guard by two bolts.

A removable sheet metal cover eliminates all danger.

With this drive "608" has twelve speeds forward and six reverse, see Fig. 46. Fig. 57 gives data for mounting drive on shop bench.

Auxiliary Countershaft Attachment

The auxiliary countershaft, Figs. 45 and 57, is bolted to horizontal safety drive when required for belt-driven grinding attachments, Page 10. The shaft runs in ball bearings and is driven by V-belt from horizontal countershaft, with interchangeable sheaves overhung, whereby necessary speed ranges may be obtained. A weighted idler pulley, swinging about the shaft, guides the round driving belt and maintains its tension. The driving pulley with its idler may be set in any position on the shaft for alignment.

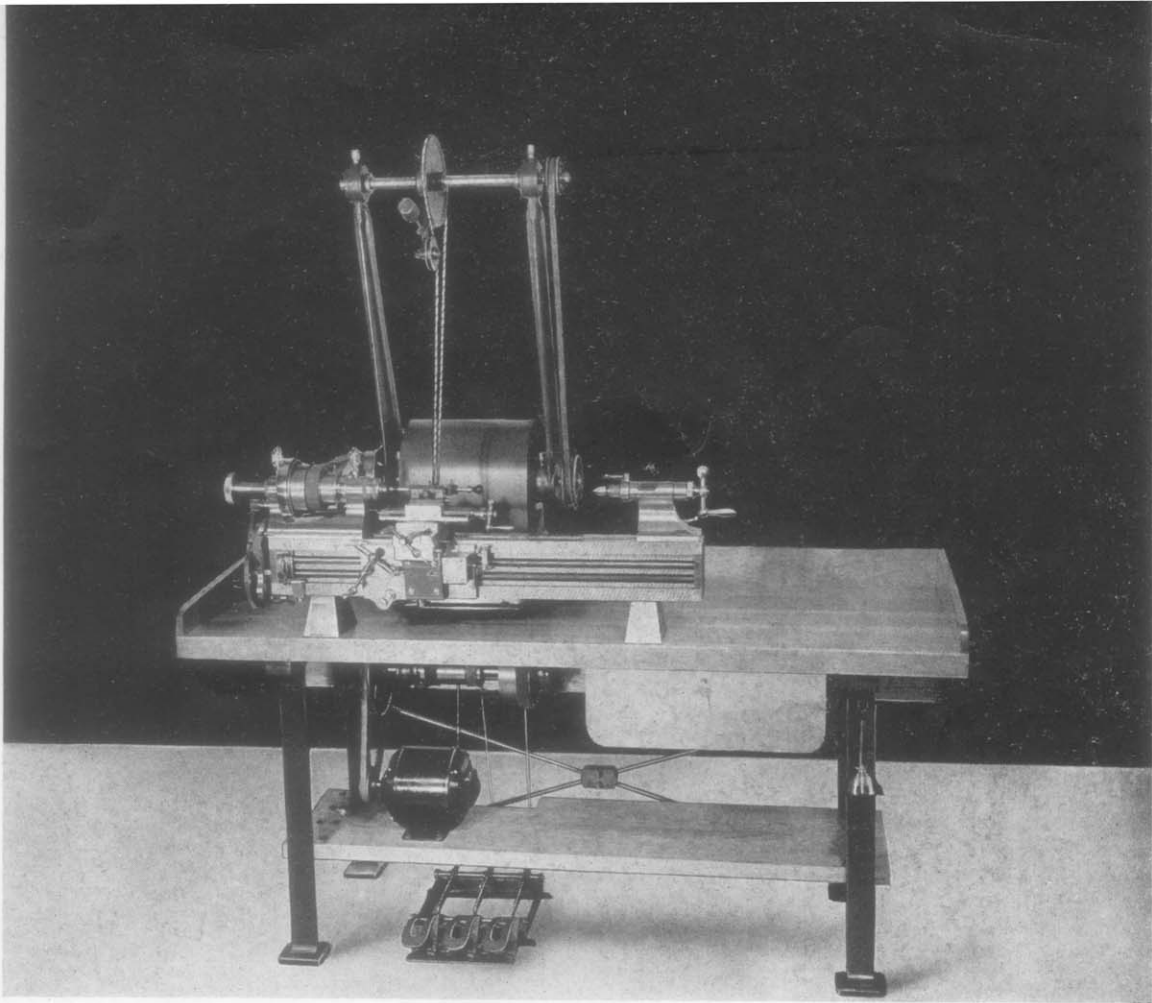

Fig. 45

UNIT BENCH WITH HORIZONTAL SAFETY DRIVE

The Unit Bench Assembly consists of 5-ply laminated maple top 72" x 26" x 2 1/4" with back and end boards and a wood drawer having collet board, tool tray, lock and key. Heavy cast iron legs, as in Figs. 45 and 51, are lagged to the top, at once affording support and assurance against possible distortion of bench surface. Steel tie rods give rigidity to the unit. For shipboard installation, where lightness is desirable, pressed steel, as in Fig. 49, are substituted for cast iron legs and flat steel braces replace the tie rods to provide against end shake. The woodwork is finished in shellac and wax and the legs painted machine tool grey.

When furnished for horizontal safety drive, Fig. 45, or individual motor drive arrangement with overhead countershaft, Fig. 51, a motor plank, bolted to leg cross-bars, is included. This plank is not required when speed box drive, Figs. 49 and 58, is used.

Dimensions of standard unit bench, together with assemblies of horizontal safety drive, speed box and overhead countershaft with support, are shown in line cuts on Page 30. Hand belt shifters or foot treadles are optional, and auxiliary countershafts, or overhead attachment motor drive, Page 26, may be carried on bench without recourse to ceiling or wall mounting. Bench assembly without drive is available if countershaft on wall, belted to an overhead lineshaft, is planned. Steel drawer and swinging

collet board are occasionally called for and supplied. A short bench, edge grain type, as shown on Page 32, may be used if space is limited.

Latch Treadles

Latch treadles in sets of three, built into a neat cast iron frame, are screwed to the floor under bench for foot control of either countershaft, Figs. 45 or 57. A pair of single treadles is used for foot control of speed box as in Fig. 49. Turnbuckles provide screw adjustment for shifter rods. Latches may be disconnected if plain treadle action is required. Fig. 46

HORIZONTAL SAFETY DRIVE			
SPINDLE SPEEDS - 608 LATHE - MOTOR 1750 R.P.M.			
4NS LATHE		5C LATHE	
BACK GEARED	OPEN BELT	BACK GEARED	OPEN BELT
51	340	45	300
71	475	61	405
103	685	85	565
116	775	102	680
163	1090	139	935
234	1560	194	1290

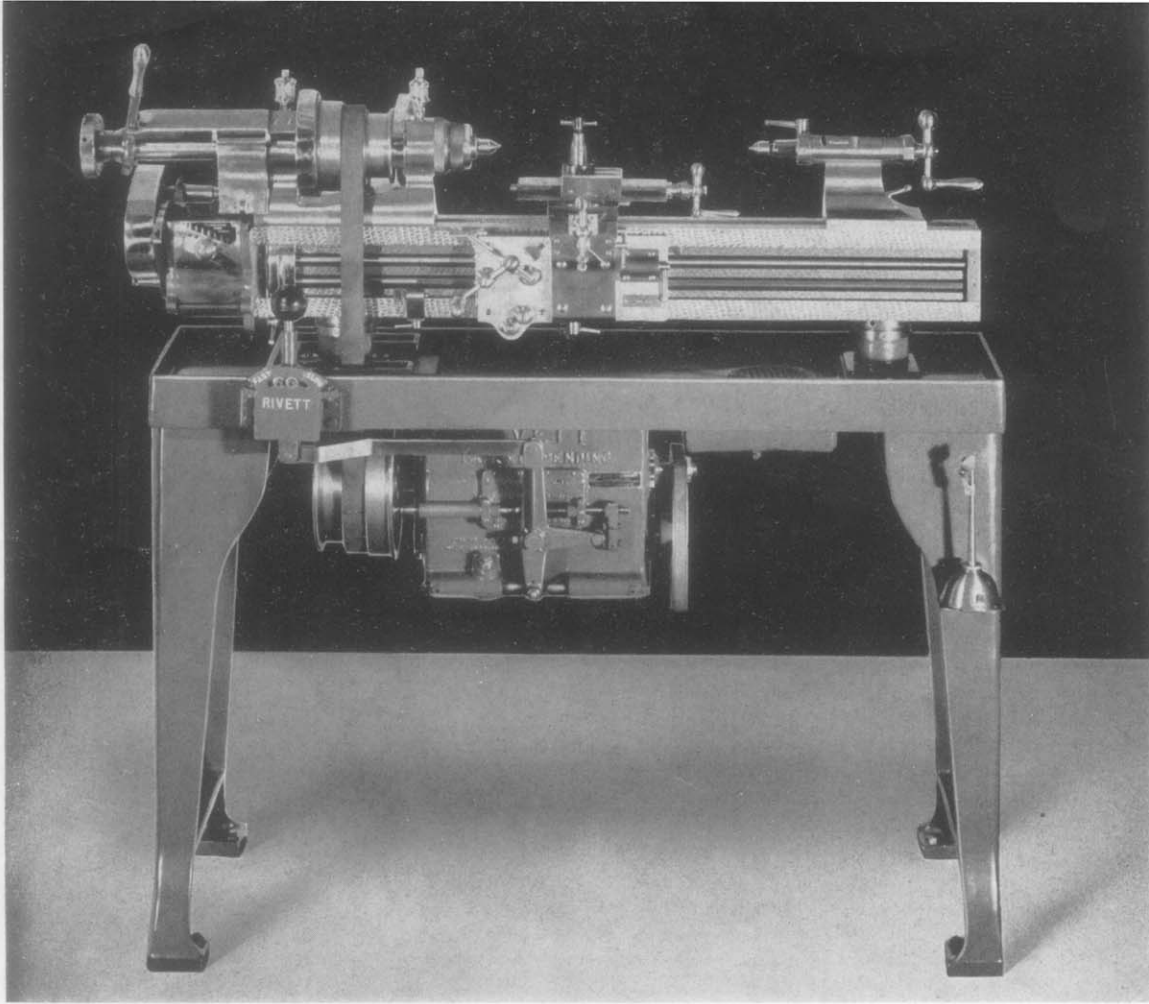
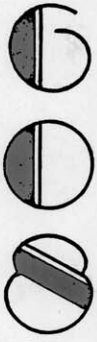

Fig. 47

OIL PAN ON LEGS WITH SPEED BOX MOTOR DRIVE

The oil pan assembly consists of pan, with oil sump, strainer and curbed belt opening of U form, on sturdy legs, Fig. 47. Endless belt from speed box driving cone may be replaced by simply passing its loop through the U-opening. This mount requires floor space approximately 48" x 24".

A 608 lathe, oil pan on legs and speed box drive is a compact equipment free from vibration and as rigid as an integral-cast unit.

If lathe will be used with turret as a screw machine requiring cutting oil, the pan is essential.

In isolated cases the convenience of bench space or cabinet drawers and compartment in addition to oil pan may be desired. It is quite practical to fit pan into bench or cabinet top and drive lathe by speed box or countershaft.

Overhead drive for lathe with oil pan on legs is afforded by supplying legs having brackets to carry overhead countershaft support, in manner like Figs. 51 and 59, but at back of pan.

Speed box on oil pan and legs, as also when mounted on bench, may be controlled by foot treadles, as seen in Fig. 49, by hand lever, Fig. 47, or, for fullest convenience, by dual hand and foot control described on Page 26.

Oil Pump and Piping

With any style of mount, oil pump and piping with nozzle, shut-off cock and splash guard, may be specified. With speed box, the pump is driven by spud and pulley on motor shaft, whereas with countershaft, an extra outboard pulley, carried at right end, is belted to pump pulley.

Pump draws its oil supply from sump through a strainer and discharges through a swivel-jointed pipe to the nozzle. A relief valve is interposed to limit the oil pressure and to by-pass surplus oil back to the sump.

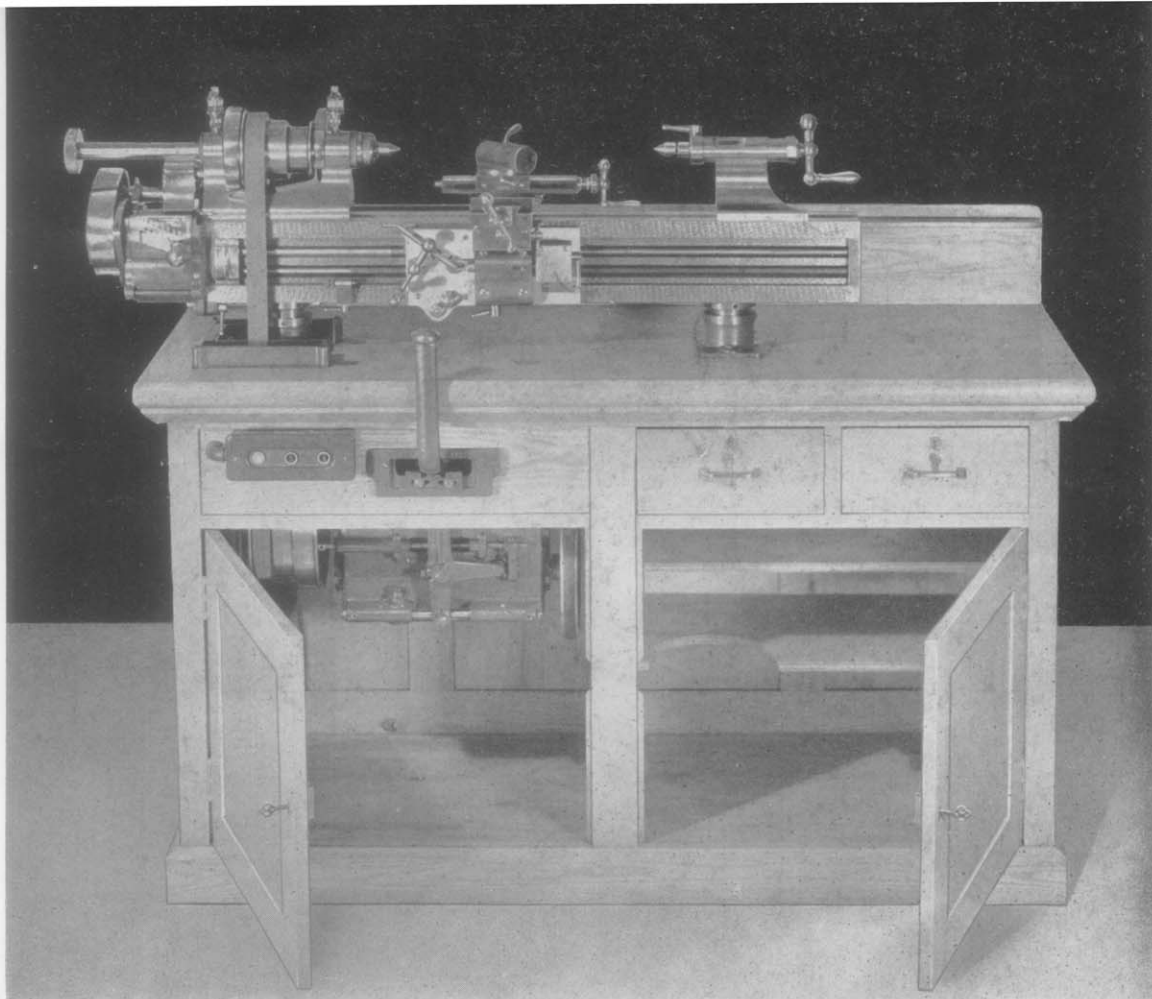
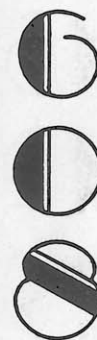

Fig. 48

CABINET WITH SPEED BOX MOTOR DRIVE

The cabinet assembly, with speed box motor drive, is shown in Fig. 48. Substantially built of solid quartered oak with 5-ply laminated top, 57" x 24" x 34" high, it affords not only an ample mount for "608" but ideal space, under lock and key, for storage of its many valuable attachments. One drawer contains a sliding board for a full set of collets. In the other, small items and tools may be lodged within reach of the operator. Shelves and floors of the compartments are arranged to contain accessories of every sort. With horizontal safety drive, Fig. 44, the cabinet is similarly a complete unit, ready to locate as received and only requiring connection of motor leads.

Speed box and overhead attachment motor drive are described on Page 26. Together, these devices provide power for lathe spindle and belt driven slide rest grinding attachments, Page 10, and traverse miller itself, but if thread milling, spiral or relieving attachments are to be considered, it is necessary to employ overhead countershaft as indicated in Figs. 32, 33 and 35. It must therefore be understood that support, shown on bench, Figs. 51 and 59, is identically mounted on cabinet, the motor and jackshaft

being located in left compartment.

The Rivett oak cabinet, with whatever drive meets the service intended, has become almost as well considered a unit as "608" itself. In laboratory, tool room and home work shop, it meets all practical demands and by reason of its handsome design and finish adds respect, as well as efficiency, to the installation of which it is a part.

Motors and Controllers

Standard $\frac{3}{4}$ H.P., 60 cycle, 1750 r.p.m. (or 50 cycle 1425 r.p.m.) motors are used with all 12-speed drives, —OC-1, HS-1 and SB-1 (see Range of Spindle Speeds, Page 31). Both countershafts provide reversal through crossed belt and consequently non-reversing switches are used. Motors run constantly. With speed box the motor is reversed. Two-speed 600-1200 r.p.m. motors are used with jackshaft drive.

Protected snap switches or push-button stop and start magnetic controllers may be included with countershaft drives while drum type reversing switches or push-button start, stop and reverse controllers are supplied for speed box and motor jack shaft drives. Variable speed equipment is special.

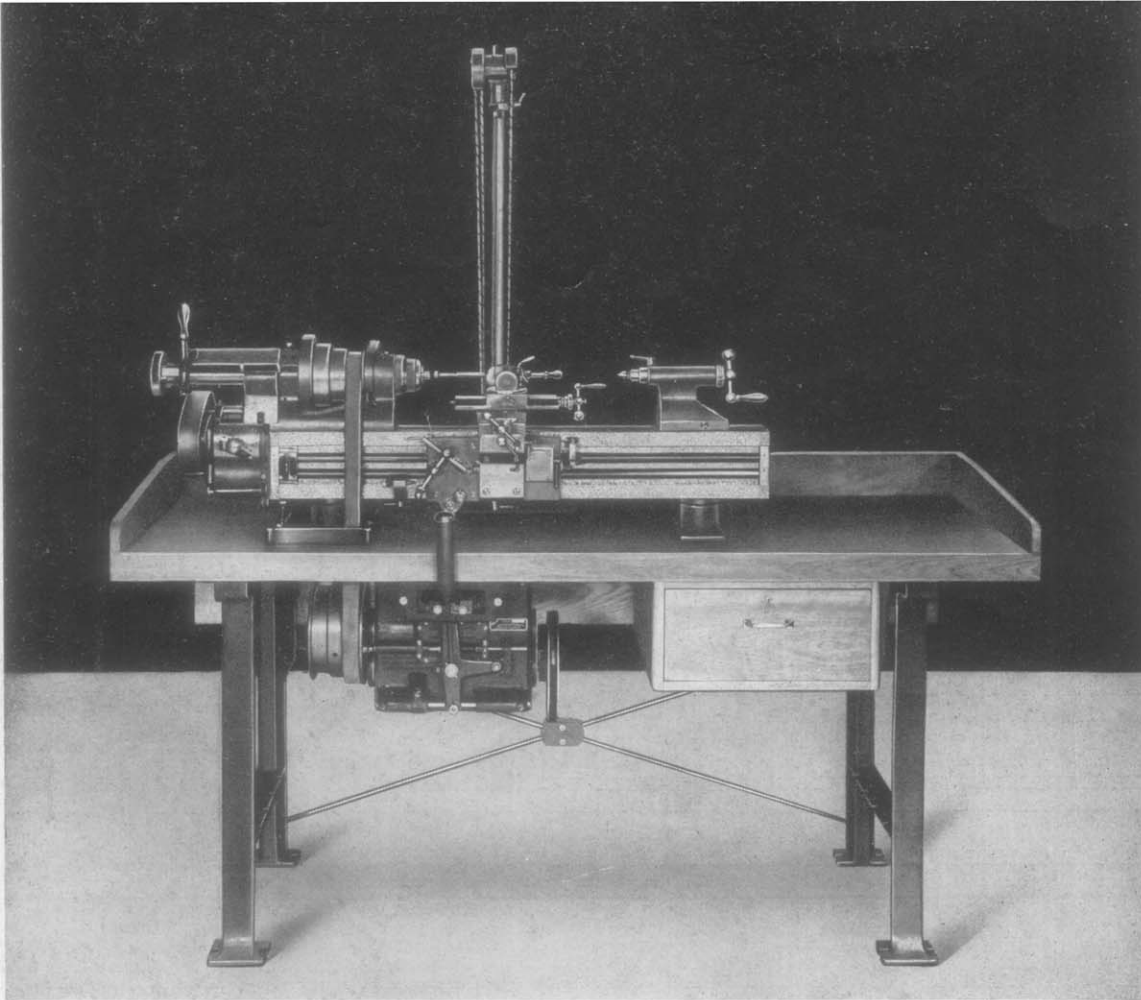
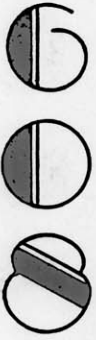

Fig. 49

SPEED BOX MOTOR DRIVE ON UNIT BENCH

The speed box motor drive is a self-contained unit consisting of a constant speed motor, reduction gearing and cone pulley suitably designed to produce the required range of lathe spindle speeds. Motor is carried on a swinging plate pivoted to rear of speed box with screw adjustment for maintaining tension of V-belt driving lower shaft. Two pairs of helical-cut spur gears of different ratio, constantly in mesh, connect lower and upper shafts. Either pair may be selectively employed by action of a two-way multiple steel disc clutch operated by foot treadles, Figs. 49 and 58, or hand levers, Figs. 47 and 48. On release of treadle or hand lever, spring action throws clutch to neutral and automatically applies a brake to driving cone pulley, instantly stopping lathe spindle. For oil pan or bench mounting a dual hand and foot control is available. By changing position of an index pin, either latch hand lever or latch foot treadles are engaged.

The speed box transmission is quiet and free from vibration. The gearing is of modern design and mounted on large diameter heat-treated alloy steel shafts running in tapered roller bearings. All moving parts are dynamically balanced. All interior parts are splash lubricated. A cover plate, easily removed, gives access to the clutch for adjustment. For speed ranges SB-1 and SB-6, see Page 31.

Auxiliary Motor Drive

The auxiliary motor drive, Fig. 49, rests on bench or cabinet top, back of lathe, and employs a ¼ H.P., 1750 r.p.m. motor. Three spindle speeds, 6000, 8000 and 10,000 r.p.m. are selectively obtained for belt driven slide rest grinding attachment through three step sheave. The drive is also used with the traverse miller, Fig. 31.

Fig. 50

SPEED BOX MOTOR DRIVE			
SPINDLE SPEEDS- 608 LATHE - MOTOR 1750 R.P.M.			
4NS LATHE		5C LATHE	
BACK GEARED	OPEN BELT	BACK GEARED	OPEN BELT
45	300	39	260
60	395	50	330
80	535	65	430
135	900	115	775
180	1180	150	1000
240	1600	195	1295

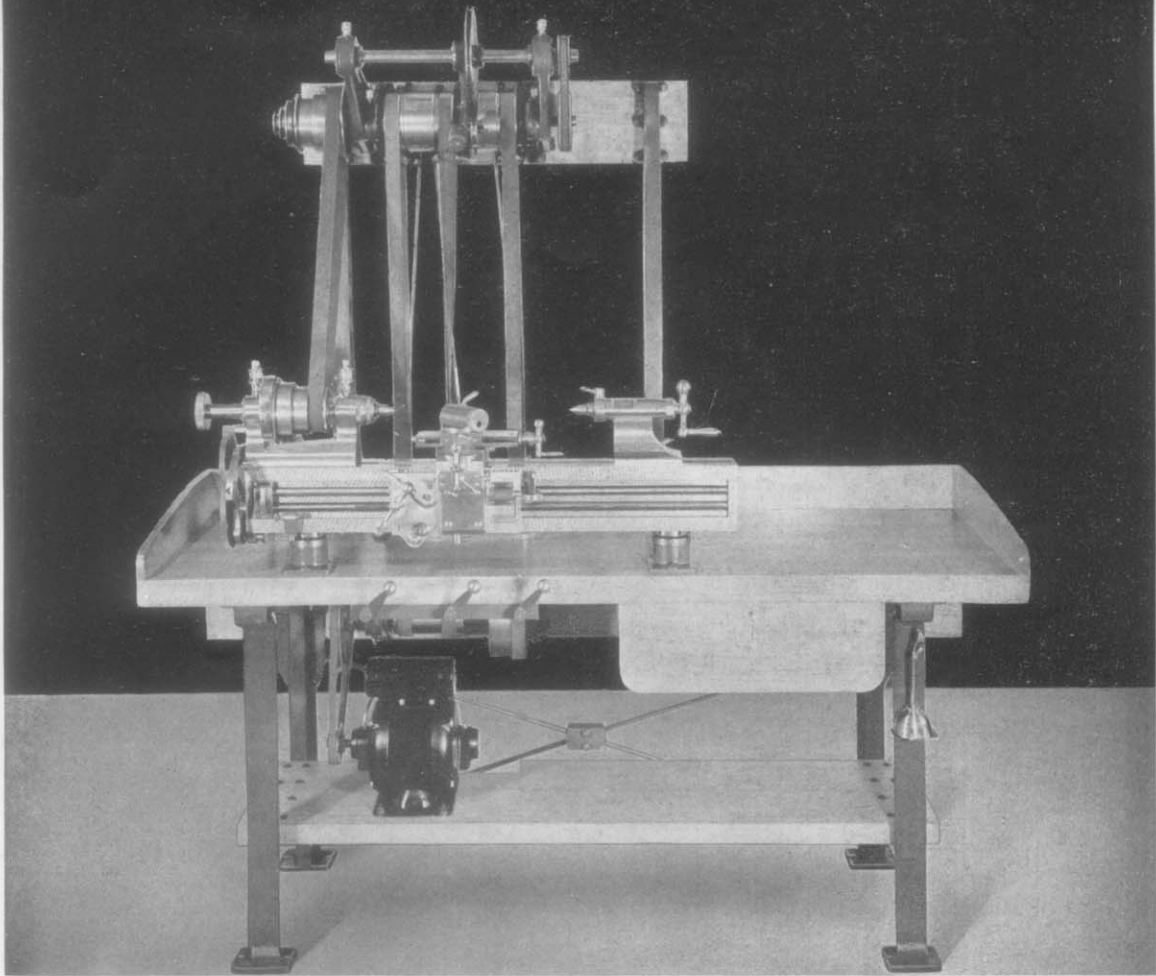
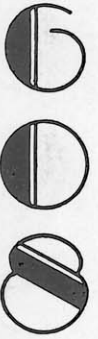

Fig. 51

OVERHEAD COUNTERSHAFT DRIVE ON UNIT BENCH

This drive comprises a three-speed, full ball bearing countershaft bolted to a hardwood plank supported above and back of lathe by two cast iron uprights mounted on bench, Figs. 51 and 59, or on cabinet. A ball bearing jackshaft, attached to back plank of mount, is driven by V-belt and single sheaves from motor to produce 12 spindle speeds OC-1, Fig. 52, or by 2-step sheaves, where 24 spindle speeds, OC-6, see Page 31, are desired. Belt opening is surrounded by a cast iron guard. Either 12 or 24-speed drive may be furnished on oil pan with legs by utilizing leg brackets cast at the rear, and a plank between.

Latch foot treadles, Page 23, and shown Figs. 45 and 57, or hand shifters, Fig. 51, serve to move three belts from loose to tight pulleys, instantly starting lathe in low or high range forward or low range reverse speeds. The motor runs constantly and is not reversed. From an overhung pulley on left end, the pedestal-type countershaft, located on bench or cabinet top in rear of lathe head, is driven. From this intermediate unit the thread milling attachment, Fig. 32, the spiral attachment, Fig. 33, and the relieving attachment, Fig. 35, receive their power.

Auxiliary Countershaft Attachment

When needed for belt-driven grinding attach-

ments, Page 10, or traverse miller, with or without its accessory thread milling, spiral and traverse grinding attachments, Pages 14 and 15, a ball bearing auxiliary countershaft is attached to the overhead countershaft brackets and driven by V-belt on a pair of overhung, interchangeable sheaves. A weighted idler pulley, swinging about the shaft, guides the round driving belt and maintains its tension. The driving pulley with its idler may be set in any position on the shaft for alignment.

Fig. 52

OVERHEAD COUNTERSHAFT DRIVE			
SPINDLE SPEEDS - 608 LATHE - MOTOR 1750 R.P.M.			
4NS LATHE		5C LATHE	
BACK GEARED	OPEN BELT	BACK GEARED	OPEN BELT
51	340	45	300
71	475	61	405
103	685	85	565
116	775	102	680
163	1090	139	935
234	1560	194	1290

608 LATHE
GEAR TABLE FOR
STANDARD
THREADS

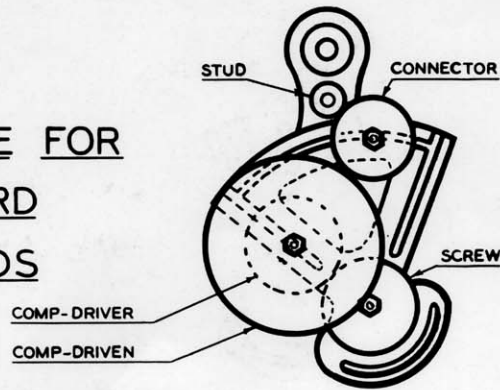

LEAD SCREW = 8 PITCH
LATHE SCREW CONSTANT = 4

FORMULA $N = \frac{2S \times P}{C \times L}$

WHERE

- S = NO. OF TEETH IN STUD GEAR
- P = NO. OF THREADS TO BE CUT
- C = RATIO OF COMPOUND
- L = NO. OF THREADS PER INCH ON LEAD SCREW
- N = NO. OF TEETH IN LEAD SCREW GEAR

NO. THR'D	STUD	COMPOUND		SCR.	NO. THR'D	STUD	COMPOUND		SCR.	NO. THR'D	STUD	COMPOUND		SCR.
		DR'N	DR'R				DR'N	DR'R				DR'N	DR'R	
10	24			60	22	24	120	60	66	44	24	120	30	66
11	24			66	24	24	120	60	72	48	24	120	30	72
11½	24			69	25	24			150	52	24	120	30	78
12	24			72	26	24	120	60	78	56	24	120	30	84
13	24			78	27	24	120	60	81	60	24	120	30	90
14	24			84	28	24	120	60	84	64	24	120	30	96
15	24			90	30	24	120	60	90	68*	24	120	30	102*
16	24			96	32	24	120	60	96	72	24	120	30	108
17*	24			102*	34*	24	120	60	102*	76*	24	120	30	114*
18	24			108	36	24	120	60	108	80	24	120	30	120
19*	24			114*	38*	24	120	60	114*	90*	24	120	30	135*
20	24			120	40	24	120	60	120	100	24	120	30	150

* SPECIAL THREADS - GEARS NOT FURNISHED WITH STANDARD EQUIPMENT

GT-10

Fig. 53

608 LATHE WITH QUICK CHANGE GEAR BOX
GEAR TABLE FOR STANDARD
AND SPECIAL THREADS

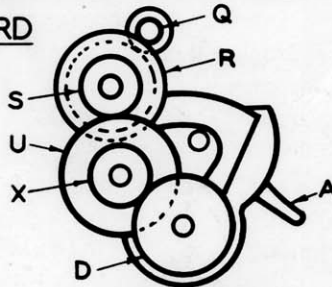

LEAD SCREW = 8 PITCH
LATHE SCREW CONSTANT = 4

FORMULA FOR SPECIAL SET-UP $N = \frac{PQSX}{4RU}$

WHERE: N = NO. OF TEETH IN GEAR D
 P = NO. OF THDS PER INCH TO BE CUT
 AND S-Q-R-U-X = NO. OF TEETH IN GEARS S-Q-R-U-X RESPECTIVELY

THREADS CUT DRIVING THRU REGULAR GEAR BOX

NO OF THREADS PER INCH								STUD		COMPOUND	
POSITION OF LEVER 'A'								DRI-VER	DRI-VEN	DRI-VER	DRI-VEN
LEFT				RIGHT							
10	11	12	13	14	16	18	30	60	70	70	
20	22	24	26	28	32	36	18	72	70	70	
40	44	48	52	56	64	72	30	60	28	112	
80	88	96	104	112	128	144	18	72	28	112	
SWING GEAR BOX TO ENGAGE 18T.							30	18	60	70	70
GEAR ON STUD WITH 60T SLIDING GEAR							120	18	60	28	112

THREADS CUT WITH SPECIAL SET-UP PER SKETCH - LEVER 'A' IN NEUTRAL

THDS PER INCH	STUD		S	T	COMPOUND		D
	Q DRI-VER	R DRI-VEN			U DRI-VEN	X DRI-VER	
11½	30	60	48	90			69
15	30	60	48	90			90
17*	30	60	48	90			102*
25*	18	72	48	90			75*
27	18	72	48	90			81
34*	18	72	48	90			102*
38*	18	72	32	90			76*
42*	18	72	32	90			84*
50*	18	72	32	90			100*
54*	18	72	32	90			108*
60*	18	72	32		80*	60*	90
68*	18	72	48		90*	45*	102*
76*	18	72	32		90*	45*	76*
100	18	72	32		90*	45*	100*

* SPECIAL THREADS - GEARS NOT FURNISHED WITH STANDARD EQUIPMENT

GT-12

Fig. 54

608 LATHE

GEAR TABLE FOR METRIC THREADS

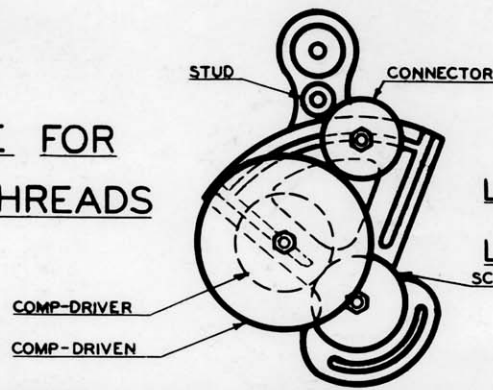

LEAD SCREW = 3M.M. PITCH

LATHE SCREW CONSTANT = 4

PITCH IN M.M.	STUD	COMPOUND		SCREW	PITCH IN M.M.	STUD	COMPOUND		SCREW
		DRIVEN	DRIVER				DRIVEN	DRIVER	
.15	15	120	30	150	.80	24	120	60	90
.25	15	120	30	90	1.00	24	120	60	72
.30	15	120	30	75	1.25	15			72
.35	21	120	30	90	1.50	24			96
.40	24	120	30	90	1.75	21			72
.45	15	120	60	100	2.00	24			72
.50	15	120	60	90	2.50	15			36
.60	15	120	60	75	3.00	24			48
.70	21	120	60	90	3.50	21			36
.75	24	120	30	48	4.00	24			36

FORMULA

$$P \times N \times C = 2S \times L$$

S = NO. OF TEETH IN STUD GEAR
 P = PITCH TO BE CUT
 C = RATIO OF COMPOUND

L = PITCH OF LEAD SCREW IN M.M.
 N = NO. OF TEETH IN LEAD SCREW GEAR

GT-22

Fig. 55

608 LATHE WITH QUICK CHANGE GEAR BOX

GEAR TABLE FOR METRIC SCREW THREADS

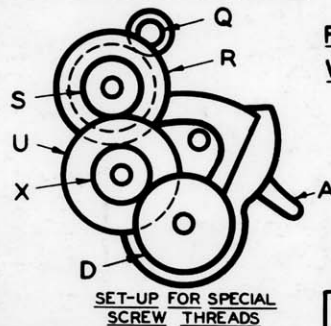

LEAD SCREW = 3M.M. PITCH
 LATHE SCREW CONSTANT = 4

FORMULA FOR SPECIAL SET-UP $N = \frac{MRD}{6Q}$
 WHERE N = NO. OF TEETH IN GEAR S
 M = MILLIMETERS LINEAR PITCH OF THREAD TO BE CUT
 Q = NO. OF TEETH IN GEAR Q
 R = NO. OF TEETH IN GEAR R
 T = NO. OF TEETH IN CONN. GEAR
 D = NO. OF TEETH IN GEAR D

THREADS CUT DRIVING THRU REGULAR GEAR BOX											
MILLIMETERS PITCH							STUD		COMP'ND		
POSITION OF LEVER 'A'							DRI-VER	DRI-VEN	DRI-VER	DRI-VEN	
LEFT			RIGHT								
2.40	2.18	2.00	1.85	1.71	1.50	1.33	30	60	70	70	
1.20	1.09	1.00	0.92	0.85	0.75	0.67	18	72	70	70	
0.60	0.55	0.50	0.46	0.43	0.375	0.33	30	60	28	112	
0.30	0.27	0.25	0.23	0.21	0.187	0.17	18	72	28	112	
SWING GEAR BOX TO ENGAGE 18T.							080	18	60	70	70
GEAR ON STUD WITH 60T SLIDING GEAR							020	18	60	28	112

THREADS CUT WITH SPECIAL SET-UP PER SKETCH-LEVER 'A' IN NEUTRAL							
M.M. PITCH	STUD		S	T	COMP'ND		D
	Q DRI-VER	R DRI-VEN			U DRI-VEN	X DRI-VER	
0.15	18	72	30		120	40	100
0.35	18	72	42		100	50	90
0.40	18	72	72		120	40	90
0.45	18	72	30	90			100
0.70	18	72	28	90			60
1.25	30	60	30	90			72
1.75	30	60	42	90			72
2.50	30	60	60	90			72
3.50	30	60	42	120			36

Fig. 56

GT-18

DRIVING EQUIPMENTS—BENCH MOUNTING

RIVETT

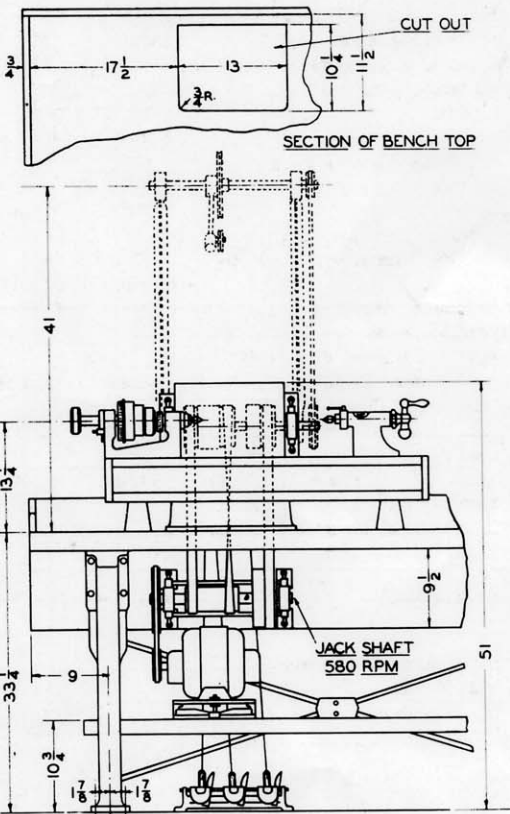

Fig. 57

Horizontal Safety Drive with Auxiliary Countershaft Attachment and Latch Foot Treadles.

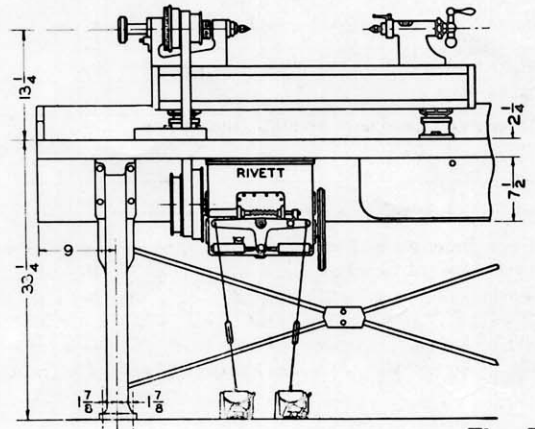
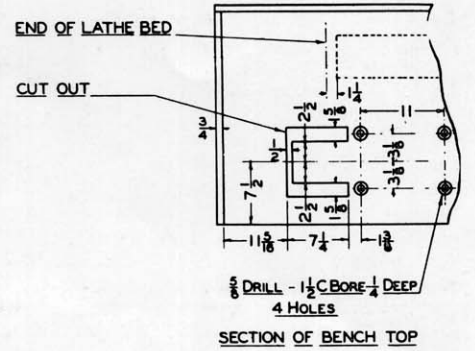

Fig. 58

Speed Box Motor Drive with Latch Foot Treadles and Overhead Attachment Motor Drive.

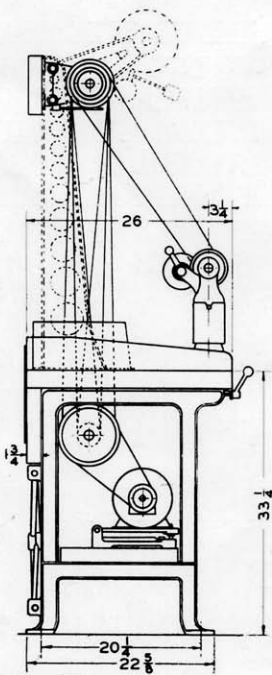
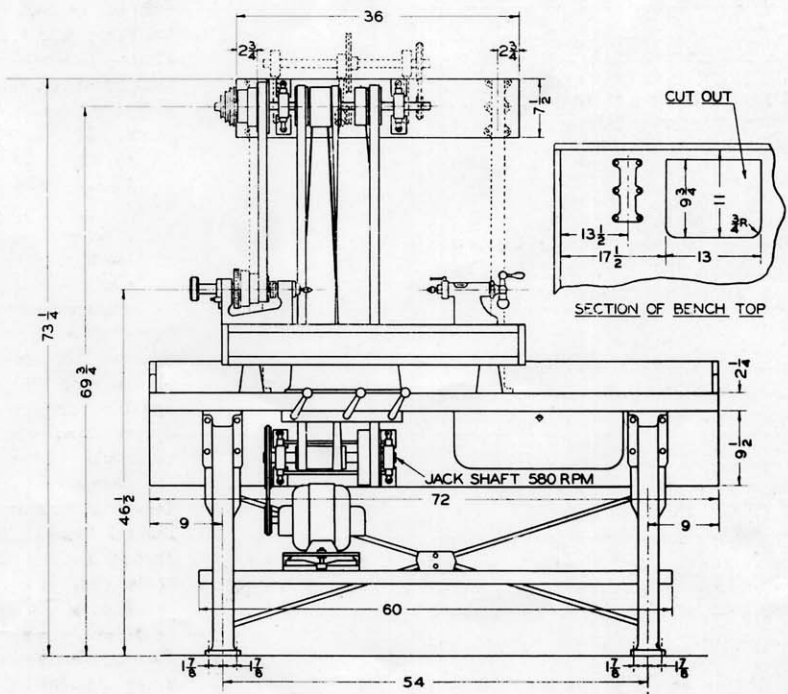

Fig. 59



Overhead Countershaft Drive with Auxiliary Countershaft Attachment and Hand Belt Shifters.

SPECIFICATIONS

	4NS	5C		4NS	5C
Swing over bed, dia.	8½"	8½"	Carriage bearing area on bed—sq. in. . .	76	76
Height, top of bed to center of spindle . .	4¼"	4¼"	Tailstock bearing area on bed—sq. in. . .	18	18
Swing over compound swivel of slide rest, dia.	2⅝"	2⅝"	Slide rest travel of top slide	5¼"	5¼"
Swing over bottom slide of compound slide rest, dia.	4¼"	4¼"	Slide rest travel of cross slide	4½"	4½"
Swing over carriage, dia.	7½"	7½"	Range of rod feeds, gear box		
Length of bed	40"	40"	Max. per rev.	0.022"	0.022"
Distance between centers, tailstock standard	19¾"	18¼"	Min. per rev.	0.0028"	0.0028"
Distance between centers, max. tailstock overhung	22¾"	21¼"	Range of rod feeds, change gear		
Max. dia. round stock held in jaw chuck, passed through spindle	1¼"	1⅛"	Max. per rev.	0.045"	0.045"
Max. dia. round hole in collet	⅝"	1"	Min. per rev.	0.0045"	0.0045"
Max. size square hole in collet	⅞"	2⅜"	Range of threads, gear box, thirty-three	10 to 144	10 to 144
Max. size across flats, hex. hole in collet	1⅞"	¾"	Range of threads, change gear, twenty-nine	10 to 100	10 to 100
Diameters of steps of headstock cone pulley	3"	3⅝"	Back gear reduction ratio, 1 to	6⅔	6⅔
(For vee belt drive see pp. 33 and 34)	3¾"	4⅜"	Range of spindle speeds (See also p. 33)		
Width of belt	1¼"	1¼"	Overhead countershaft drive OC-1		
Threads on headstock spindle nose—Form (Hard Ground) Outside dia.	1⅝"	2¼"	1750 r.p.m. motor—12 speeds (p. 27)	51-1560	45-1290
Pitch	12	10	Horizontal safety drive HS-1		
Headstock bearing area on bed—sq. in.	30	35	1750 r.p.m. motor—12 speeds (p. 22)	51-1560	45-1290
			Speed box motor drive SB-1		
			1750 r.p.m. motor—12 speeds (p. 26)	45-1600	39-1295
			Tailstock—Spindle dia.	1"	1"
			Taper in mouth, Rivett spec. approx.	3°	3°
			Dia. of hole at open end541"	.541"
			Travel	3¼"	3¼"
			Scale graduations	3" x ¼"	3" x ¼"

RIVETT

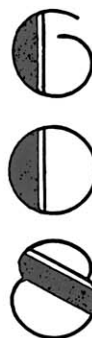

Floor dimensions: bench 72" x 26"; oak cabinet 57" x 24"; oil pan 50" x 20".
 Lathe and standard attachments approx. 350 lbs. Shipping wghts.—domestic—two cases—add 100 lbs. total.
 Boxed, ocean shipment—two cases add 175 lbs. total. Cubic feet—boxed, ocean shipment—16.
 Net wghts.: drive complete with bench 425 lbs., with oak cabinet 550 lbs., with oil pan 500 lbs.
 Shipping wghts.: domestic, crated, add 200 lbs. Shipping wghts.: boxed for ocean shipment, add 350 lbs. total.
 Cubic feet: boxed for ocean shipment: bench 100, cabinet 52, oil pan 32.

INDEX

	Fig.	Page		Fig.	Page
Angle Iron	40	18	Lever Chuck Closer:—Change Gear Lathe	3	4
Arbors—Internal Wheel	22	10	Gear Box Lathe	4	4
Bench, Unit	45	23	Milling Attachments—Carriage	26	12
Cabinet, oak	48	25	Slide Rest	25	12
Cabinet, steel	60	33	Thread	32	14
Carriage and Saddle	5	5	Traverse	31	14
Centers	42	20	Motors and Controllers		25
Change Gears	3	4	Oil Pan, on legs	47	24
Chucks:—Center	42	20	Oil Pump and Piping		24
Drill, Jaw and Step	43	21	Plates—Driving and Face	41	19
Collets	43	21	Quick Change Gear Box	4	4
Cutting Off and Forming Slide	38	17	Relieving Attachment	35	15
Cutting Off and Turning Slide	39	17	Rests:—Ball Turning	23	11
Dog, Clamp	40	18	Comp. Slide, Eccentric	6	6
Drawer, Wooden Bench Type	45	23	Comp. Slide, Rocker	8	7
Drives:—Diagrams		30	El	40	18
Overhead C'shaft	51	27	Follower	40	18
Overhead C'shaft with aux. c'shaft att.	51	27	Steady	40	18
Horizontal Safety	44	22	Tee	40	18
Horizontal Safety with aux. c'shaft att.	45	23	Triangle	40	18
Motor Jackshaft	60	33	Saw Table	40	18
Speed Box Motor	49	26	Slotting Attachment	29	13
Speed Box Motor, Auxiliary Motor Drive	49	26	Slotting and Milling Fixtures	40	18
Electrical Controllers		25	Specifications		31 & 33
Gear Tables:—English	53 & 54	28	Spiral Attachment	33	15
Metric	55 & 56	29	Tailstocks:—Offset, Set-over	10	8
Grinder, Traverse	34	15	Lever	13	8
Grinding Attachments:—Belt Driven			Taper Attachment	15	9
Internal, Ecc. Slide Rest Type	18	10	Thread Dial	5	5
External, Ecc. Slide Rest Type	19	10	Thread Tool	24	11
Internal, Rocker Tool Post Type	20	10	Tools:—Ecc. Slide Rest Type	7	6
External, Rocker Tool Post Type	21	10	Rocker Tool Post Type	9	7
Grinding Attachment:—Unit Motor Drive			Treadles, Latch	45	23
Internal set-up	16	9	Turrets, Automatic Indexing	36	16
External set-up	17	9	Turret Attachment, Tailstock	12	8
Indexing Attachments:—Change Gear Lathe	30	13	Turret Tools	37	16
Gear Box Lathe	29	13	Vises:—Ecc. Slide Rest Type	41	19
Interlock, Carriage	5	5	Rocker Tool Post Type	41	19
Kaurling Attachment	14	8			

PAGE

OTHER RIVETT MACHINES

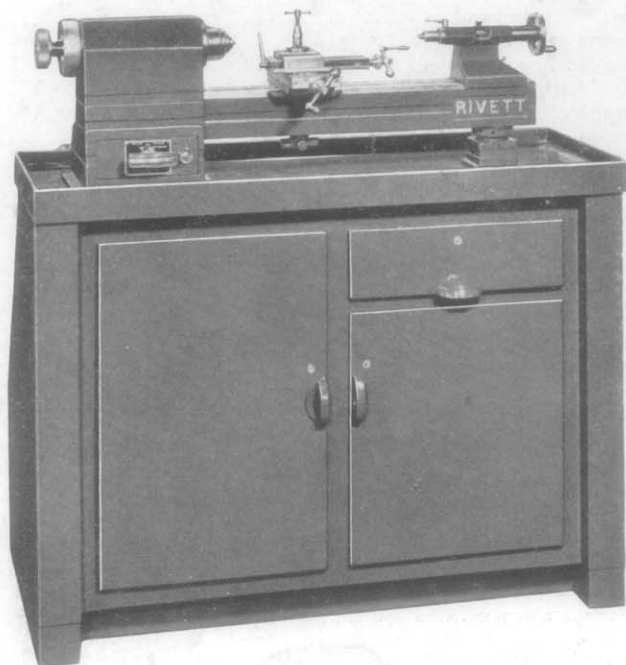

Rivett Series 715 Plain Precision Ball Bearing Bench Lathe on Metal Cabinet with Motor Drive. Collet Capacity $\frac{3}{4}$ "', Swing 7"', Bed 33"'.



Rivett Series 918 Ball Bearing Hand Screw Machine on Metal Cabinet with Motor Jackshaft Drive. Collet Capacity 1"', Swing 9"', Bed 39 $\frac{1}{2}$ ". Also furnished as plain Lathe.

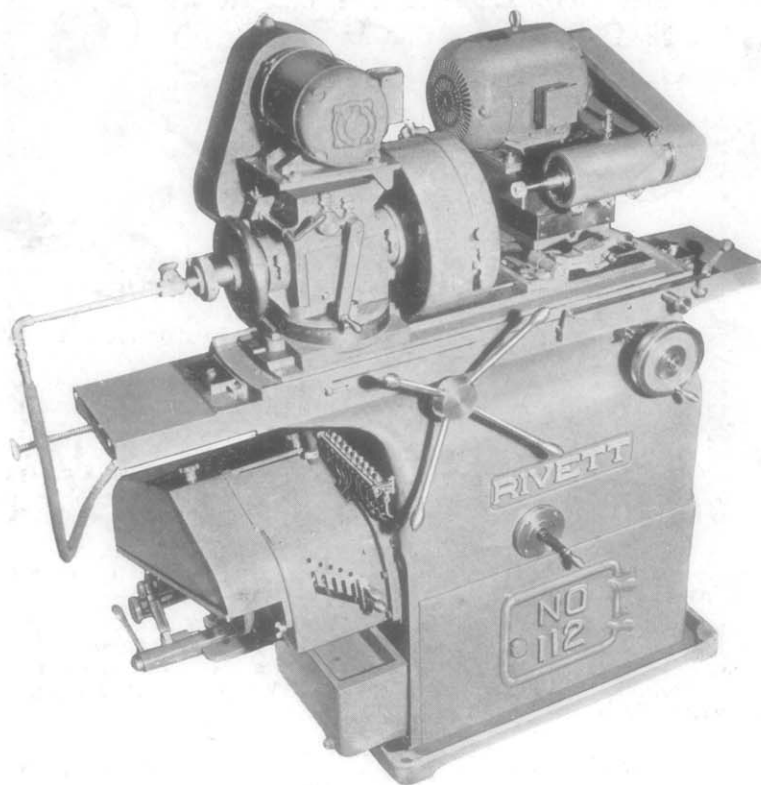

Rivett No. 112 Universal Grinder, 8" Power Reciprocation, 14" Swing.

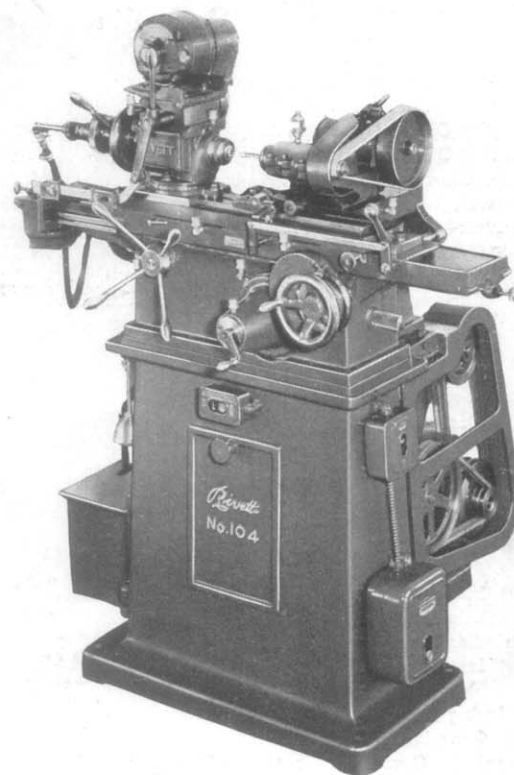

Rivett No. 104 Internal-External Grinder, 2" or 4" Power Reciprocation, 8" Swing.

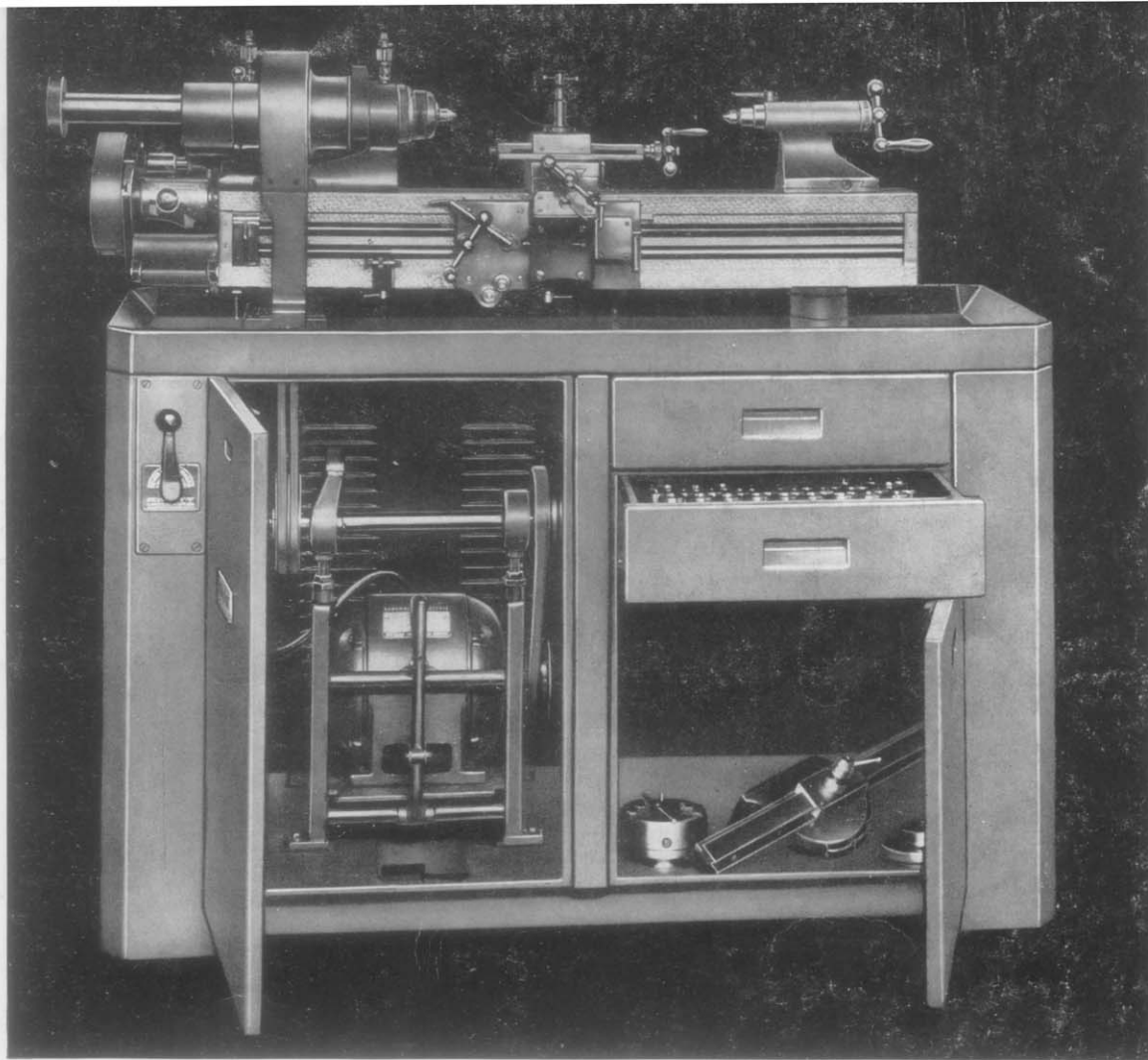

Fig. 60

608-PV-5C SEMI-ENCLOSED VEE SHEAVE HEAD, QUICK CHANGE GEAR LATHE SPECIFICATIONS

Swing over bed, dia	8 1/2"	Tailstock bearing area on bed—square inches	18
Height, top of bed to center of spindle	4 1/4"	Slide rest, travel of top slide	5 1/4"
Swing over compound swivel of slide rest, dia.	2 5/8"	Slide rest, travel of cross slide	4 1/2"
Swing over bottom slide of compound slide rest, dia.	4 1/4"	Range of rod feeds with Quick Change Gear Box:	
Swing over carriage, dia.	7 1/2"	Max. per rev.	0.0220"
Length of bed	40"	Min. per rev.	0.0028"
Distance between centers, tailstock standard	18 1/4"	Range of threads through Quick Change Gear Box: thirty-	
Distance between centers, tailstock overhung max.	21 1/4"	three (including 11 1/2, 15 and 27) see Gear Tables,	
Diameter round stock held in jaw chuck, passed through		pages 28 and 29	10 to 144
spindle, max.	1 1/8"	Back Gear reduction ratio	1 to 6 3/4
Hole through spindle	1 1/4"	Tailstock—Spindle dia.	1"
Diameter round hole in collet, max.	1"	Taper in mouth, Rivett spec. approx.	3°
Square hole in collet, max.	23/32"	Dia. of hole at open end541"
Hex. hole in collet size across flats, max.	7/8"	Travel	3 1/4"
Threads on headstock spindle nose—Form	U.S.	Scale graduations	3" x 1/16"
(Hard Ground) Outside dia.	2 1/16"	Spindle Speeds—Motor Jackshaft Drive—twelve:	
Pitch	10	r.p.m. { 25-50-90-120-145	
Headstock bearing area on bed—square inches	35	{ 180-240-290-580	
Carriage bearing area on bed—square inches	76	{ 750-1160-1500	

Cabinet Assembly—53" x 26" welded steel with oil pan top, 53" x 20 1/2" with 1 3/4" rim, two drawers, 17" x 4 3/8" x 18 1/4" deep, one with collet board and one with slide, storage compartment for attachments, 22" x 17" x 24", deep, ventilated motor compartment.

Drive—Motor Jackshaft, Fig. 60, complete electrical control twelve selective spindle speeds 25 to 1500 r.p.m. 600/1200 r.p.m., 220, 440 or 550* volt 3/4 H.P. motor. Welded frame supports all parts of drive and mounts on cabinet floor. Drive is controlled electrically by single switch lever and may be started with rapid acceleration in low or high speed. Two-speed motor is carried on sliding cradle with lever for releasing tension of driving Vee belts and shifting on three-step motor and jackshaft sheaves. Vee belts are tensioned by screw adjustment and renewed without disassembly of any part of drive.

Weights:

Lathe, standard attachments, mount and drive	net 1050 lbs. approx.
Shipping weight, domestic, one crate	1250 lbs. approx.
Shipping weight, ocean shipment, one box	1400 lbs. approx.
Cubic feet: boxed for ocean shipment	52 approx.

*Magnetic controller required for 550 volt.

RIVETT
LATHE & GRINDER
INCORPORATED

