

RIVETT

MILLING ATTACHMENT



RIVETT LATHE & GRINDER Inc.

BRIGHTON • BOSTON • MASS • U • S • A •

BULLETIN 130

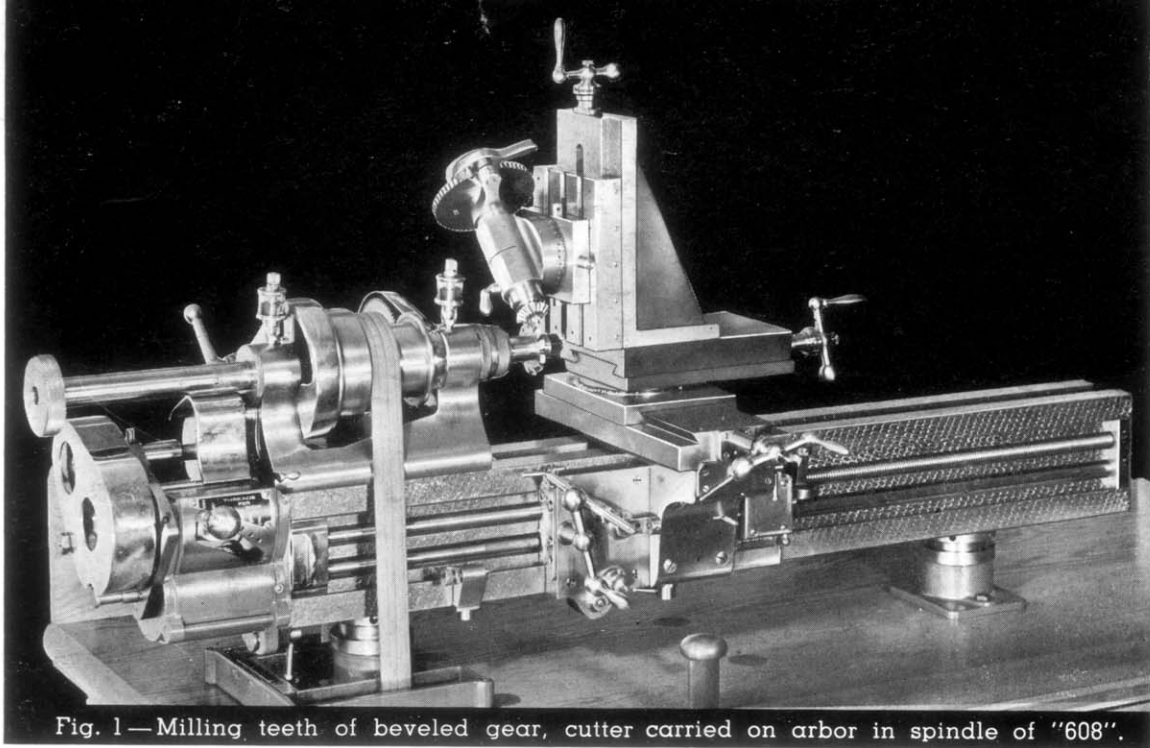

Fig. 1—Milling teeth of beveled gear, cutter carried on arbor in spindle of "608".

RIVETT BENCH LATHE MILLING ATTACHMENT

The Rivett Universal Milling Attachment is designed to mount on Rivett precision bench lathes, on plain bench lathes of other makes having swing of 8" or more and on small screw-cutting lathes having swing over saddle 7½" or more. Its use greatly increases the earning power of an expensive plain or screw-cutting lathe in laboratory, experimental department or toolroom, for while employing the inherent accuracy of the lathe itself, it adds to the field of close-limit operations which can be performed without materially increasing the investment in precision tools.

No other milling attachment is capable of as great a range in size and variety of work. The several methods which it presents for mounting parts to be machined and the wide adjustments of the three slides and the horizontal and vertical swivels make practical any milling operation within the generous capacity of the attachment.

Milling cutters may be mounted on arbors held directly in lathe spindle, or cutters with straight shanks may be held in collets or cutters with taper shanks may be held in center chuck. Lathe spindle provides adequate range of cutting speeds. Work may be held in collet or vise mounted on milling attachment spindle

or may be directly strapped or held in vise on vertical slide or angle iron. With the adjustments which provide for locating work so held in relation to the cutter, vertical, horizontal and angular milling can be done within the full range of slide movement without change of set-up. Illustrations also show boring and drilling jobs easily and accurately performed.

Universal movements in three directions are by carbon steel feed screws working in long bronze nuts controlled by ball handles with adjustable graduated dials. Base has transverse slide carrying horizontal swivel which is graduated over its full circumference and on which mounts upper slide carrying strongly-ribbed vertical-faced knee. Horizontal swivel is locked by conical binder and nut.

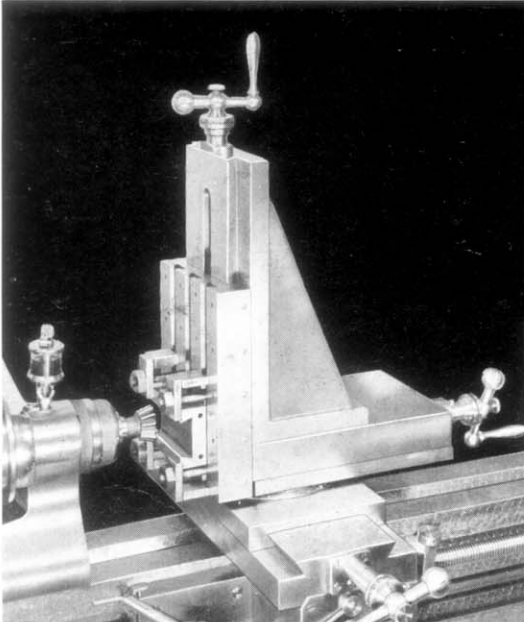

Fig. 2—Milling dovetail on "608"

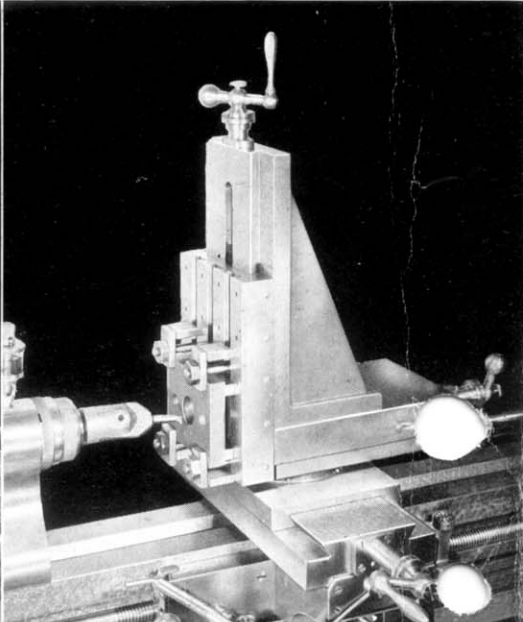

Fig. 3—Jig boring on "608"

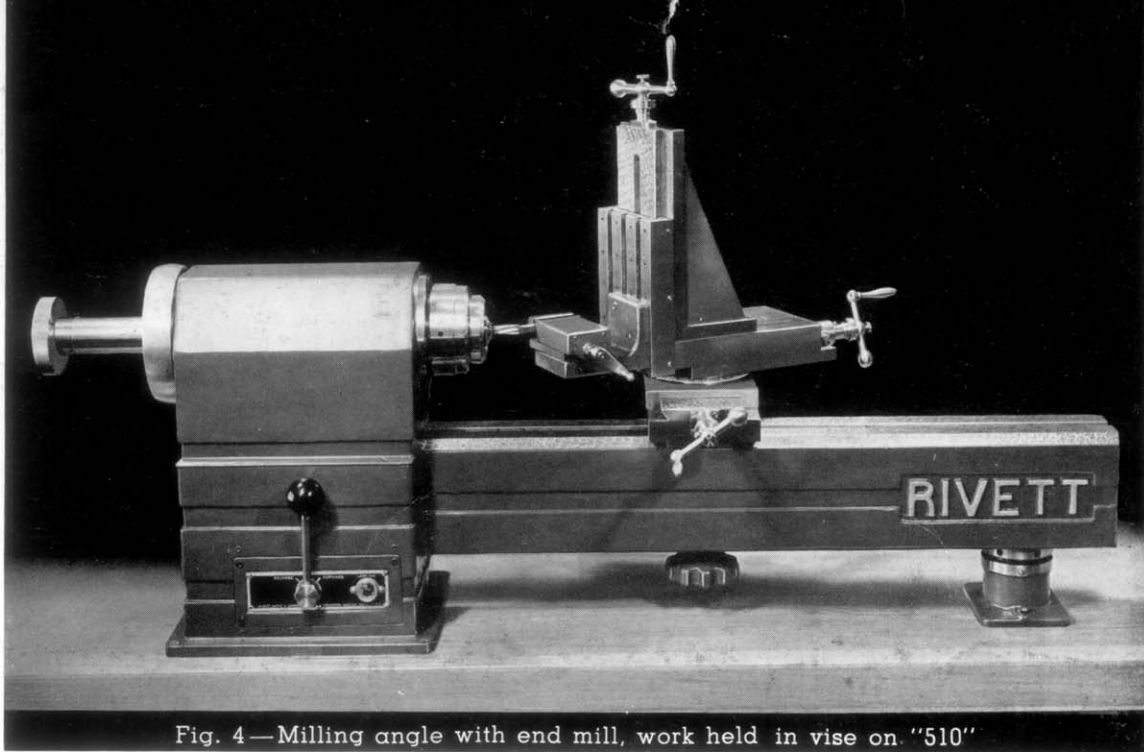

Fig. 4—Milling angle with end mill, work held in vise on "510"

Knee is fitted with vertical-fed steel-faced slide having three T slots which provide a large area for locating vertical swivel. This swivel is graduated over its full circumference and mounts index spindle in which collets or vise are used. Index plates fit rear of spindle. Swivel may be removed from vertical slide when attaching work, vise or angle iron directly thereto.

Instrument makers and repair shops, manufacturers of temperature control and other small fine assemblies and scientific research men may convert a favorite lathe to become a necessary miller and reconvert to a lathe in the space of a few minutes by adding to their equipment one of these unique attachments.

Used with Rivett 608 Screw Cutting Bench Lathe

When used with Rivett 608 lathe, Fig. 1, the milling

attachment is equivalent to a power-fed universal milling machine. It mounts on the saddle of the carriage in place of the slide rest. Longitudinal power feed is by carriage travel. Power cross feed is from cross feed gear in carriage. Figs. 2 and 3 illustrate the attachment in other set-ups on the 608 lathe.

Used with Rivett 505 and 510 Plain Bench Lathes

When used with Rivett 505 open head plain lathe, Fig. 5, and Rivett 510 lathe, Fig. 4, the universal milling attachment mounts on the standard slide rest shoe and is held to the bed by clamping bolt and knob, Fig. 6. The base may be located in any transverse and longitudinal position required by the work. The shoe automatically squares the attachment at right angles to the line of lathe centers.

Used with Other Manufacturers' Plain Bench Lathes

When the Rivett milling attachment is used on lathes of other makes, it must be equipped with special shoe, bolt and knob. Customer should furnish with his order an accurate cross-section drawing of his lathe bed and state center height so proper mounting shoe can be machined. The top surface of shoe will be scraped to receive the base of attachment. Customer will scrape the under surface of shoe to produce true right angularity with his center line.

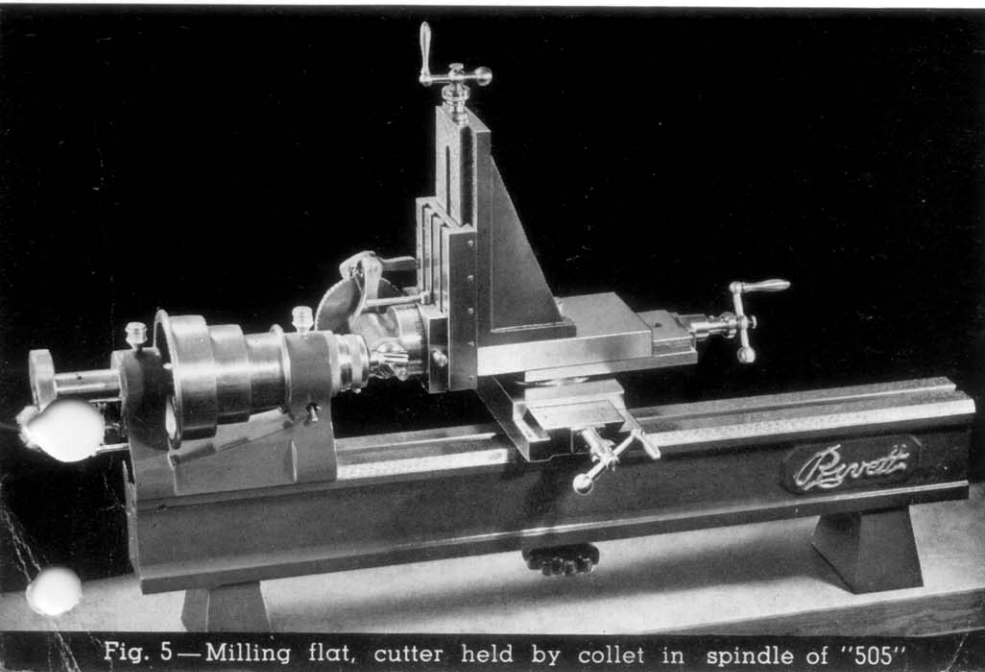

Fig. 5—Milling flat, cutter held by collet in spindle of "505"

ATTACHMENTS

RIVETT

M
I
L
L
I
N
G

A
T
T
A
C
H
M
E
N
T



Fig. 6 - Shoe with Clamping Bolt and Knob



Fig. 7 - Cutter Arbor

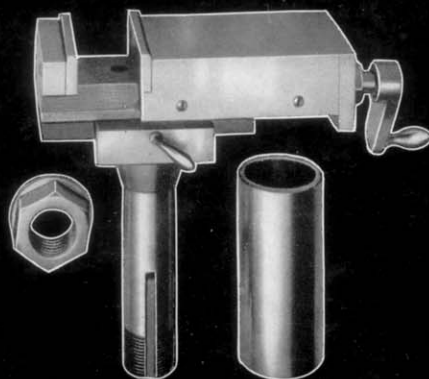

Fig. 8 - Vise for Vertical Swivel

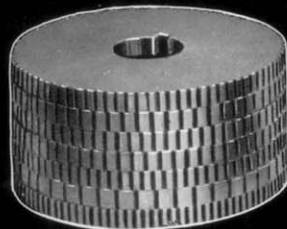

Fig. 9 - Index Plates

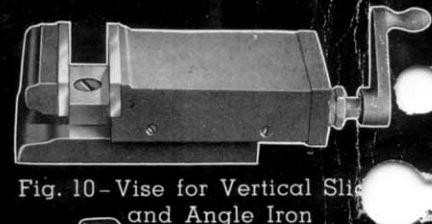

Fig. 10 - Vise for Vertical Slide and Angle Iron

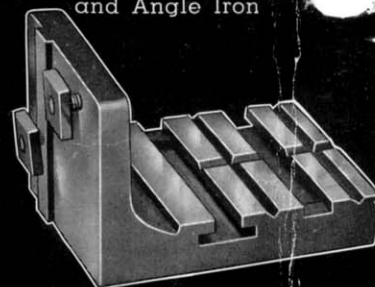

Fig. 11 - Angle Iron



Fig. 12 - Center Chuck

ATTACHMENTS

FIG. 6. — Shoe with Clamping Bolt and Knob—the shoe and the milling attachment are both held securely to the lathe bed in desired location by clamping bolt and knob.

FIG. 7. — Cutter Arbor—draws into lathe headstock spindle and mounts cutter as shown in Fig. 1. Arbors are furnished in the following sizes: 1/4", 5/16", 3/8", 7/16", 1/2", 9/16", 5/8", 11/16", 3/4", 13/16", 7/8" and 1".

FIG. 8. — Vise for Vertical Swivel—is held by collet shank directly in milling attachment index spindle. With sleeve fitted over shank it mounts in index spindle holder. Jaws are hardened steel with 1 1/2" maximum opening.

FIG. 9. — Index Plates—mount on the rear of index spindle and divide the work, see Fig. 1. Eight plates,

one each with 45, 56, 60, 64, 72, 80, 84 and 100 divisions are furnished.

FIG. 10. — Vise for Vertical Slide and Angle Iron—has tongued base for fitting in tee slots, see Fig. Jaws are hardened steel with 1 3/4" maximum opening.

FIG. 11. — Angle Iron—has tongued and ribbed base for mounting in tee slots of steel-faced vertical slide. It has tee slots for clamping work or vise, Fig. 4, and vee grooves for locating round work. Length 4 1/4", width 3 1/4", height 3".

FIG. 12. — Center Chuck—fits lathe headstock spindle and has hole for mounting cutters with No. 5 or No. 7 B. & S. tapered shanks, see Fig. 2. Specify size of taper hole required.

SPECIFICATIONS

BASE AND TRANSVERSE SLIDE

Length of base	12"
Width of base	5"
Transverse slide area in square inches84
Travel of transverse slide	8 1/2"
Transverse slide dial graduated to	0.001"
Horizontal swivel graduations—in degrees360

UPPER SLIDE

Length of upper slide	8"
Width of upper slide	5 1/8"
Upper slide area in square inches56
Travel of upper slide	2 3/8"
Upper slide dial graduated to	0.001"

KNEE AND VERTICAL SLIDE

Height of knee	9 3/8"
Width of knee	5"
Vertical slide area in square inches49
Travel of vertical slide	5 1/2"
Vertical slide dial graduated to	0.001"
Work-holding steel surface of vertical slide	5 1/8" x 7"
Three vertical slide tee slots, width	7/16"

VERTICAL SWIVEL AND SPINDLE

Vertical swivel graduation in degrees360
Index spindle formed to take Rivett 4-NS or 5-C collets.	
Maximum capacity of Rivett 4-NS collet	5/8"
Maximum capacity of Rivett 5-C collet	1"
Weight of Milling Attachment85 lbs.

STANDARD EQUIPMENT FURNISHED WITH MILLING ATTACHMENT

Base, transverse, upper and vertical slides; vertical swivel with index spindle for 4-NS or 5-C collets as specified; 4-NS collets; eight index plates, one each with 45, 56, 60, 64, 72, 80, 84 and 100 divisions.

Price for use on Rivett bench lathe already equipped with slide rest shoe or carriage saddle \$275.00

Price of special shoe with bolt and knob to customer's dimensions — on application.

800.-