

TECHNICAL MANUAL
OPERATOR'S, ORGANIZATIONAL, DIRECT
SUPPORT AND GENERAL SUPPORT
MAINTENANCE MANUAL

FOR
SHAPER, METAL CUTTING,
HORIZONTAL
MODEL CS100
(SOUTH BEND LATHE)
(NSN 3418-00-223-0969)

THIS PUBLICATION IS A COURTESY QUICK COPY FROM THE UNITED STATES ARMY PUBLICATIONS DISTRIBUTION CENTER, ST. LOUIS, MISSOURI, TO MEET YOUR NEEDS WHILE WE REPLENISH OUR REGULAR STOCK.

HEADQUARTERS, DEPARTMENT OF THE ARMY

FEBRUARY 1982

TECHNICAL MANUAL

NO. 9-3418-200-14&P

HEADQUARTERS
DEPARTMENT OF THE ARMY
WASHINGTON, DC, 26 February 1982

**Operator's, Organizational, Direct Support
and General Support Maintenance Manual
For**

SHAPER, METAL CUTTING, HORIZONTAL

MODEL CS100

(NSN 3418-00-223-0960)

REPORTING ERRORS AND RECOMMENDING IMPROVEMENTS

You can help improve this manual. If you find any mistakes or if you know of a way to improve the procedures, please let us know. Mail your letter, DA Form 2028 (Recommended Changes to Publications and Blank Forms or DA Form 2028-2, located in the back of this manual direct to: Commander, US Army Armament Materiel Readiness Command, ATTN: DRSAR-MAS, Rock Island, IL 61299. A reply will be furnished directly to you.

NOTE

This manual is published for the purpose of identifying an authorized commercial manual for the use of the personnel to whom this equipment is issued.

Manufactured by: South Bend Lathe
400 West Sample Street
South Bend, IN 46621
Procured under Contract No. DAAA09-76-C-6387

This technical manual is an authentication of the manufacturers' commercial literature and does not conform with the format and content specified in AR 310-3, Military Publications. This technical manual does, however, contain available information that is essential to the operation and maintenance of the equipment.

INSTRUCTIONS FOR REQUISITIONING PARTS

NOT IDENTIFIED BY NSN

When requisitioning parts not identified by National Stock Number, it is mandatory that the following information be furnished the supply officer.

- 1 - Manufacturer's Federal Supply Code Number - 55985
- 2 - Manufacturer's Part Number exactly as listed herein.
- 3 - Nomenclature exactly as listed herein, including dimensions, if necessary.
- 4 - Manufacturer's Model Number - Model CS100
- 5 - Manufacturer's Serial Number (End Item)
- 6 - Any other information such as Type, Frame Number, and Electrical Characteristics, if applicable.
- 7 - If DD Form 1348 is used, fill in all blocks except 4, 5, 6, and Remarks field in accordance with AR 725-50.

Complete Form as Follows:

and (a) In blocks 4, 5, 6, list manufacturer's Federal Supply Code Number - 55985 followed by a colon manufacturer's Part Number for the repair part.

(b) Complete Remarks field as follows:

Noun: (nomenclature of repair part)
For: NSN: 3418-00-223-0960
Manufacturer: South Bend Lathe

Model: CS100

Serial: (of end item)

Any other pertinent information such as Frame Number, Type, Dimensions, etc.

TABLE OF CONTENTS

<u>Subject</u>	<u>Page</u>
Introduction -----	1
Description -----	1-4
Set-Up and Leveling -----	5
Cutting Tools -----	6-10
Mounting Work -----	11-13
Adjustments -----	13
Operation -----	14-24
Lubrication -----	25
General Maintenance -----	26
Repair Instructions -----	27
Adjusting Oil Pump -----	28
Parts List -----	29-35
Care of Machine Tools not in use -----	36

HOW TO RUN A METAL WORKING SHAPER

INTRODUCTION

The shaper is a machine tool used principally for producing a flat or plane surface which may be in a horizontal, a vertical, or an angular plane. In addition, the shaper is used to machine odd and irregular shapes which would be difficult to produce on any other machine.

Shapers are classified in several different ways, for example, the name applied to a given design may indicate the action of the machine when in operation, the type of driving mechanism, or other constructional features. The type of shaper that is most commonly used, in machine shops and tool rooms is sometimes known as a COLUMN SHAPER, because of the vertical column or frame which supports the ram, work table, and driving mechanism. Still another term used to designate the most common type shaper is the CRANK SHAPER. The name relates to the crank-driving mechanism for the ram.

The shaper is a column shaper of the crank-driven type as shown in figure 1. A single-point cutting tool attached to a rigid arm called the RAM moves over the work with a reciprocating (alternate forward and backward) motion. The length of the ram stroke and the number of strokes per minute may be varied as the length of the work and its composition dictates.

The size of the shaper is designated by the maximum length of its stroke given inches. The various parts and adjustment of the shaper are shown in figures 1, 2, 3, 4, and 5.

DESCRIPTION

THE 7" BENCH SHAPER has the built-in accuracy and versatility for rapid machining on small parts. The stroke rate per minute is higher than on larger shapers, permitting greater production on work within its capacity. The ease of setting up work in the bench shaper, its high operating speeds, and the low power consumption of the fractional HP motor, keep posts to a minimum. It is capable of the most exacting work on parts within its capacity.

RAM has long precision ground dovetail bearings with gib adjustment which provide rigid support for the cutting tool, even in the extreme forward position. Length of stroke is regulated by crank gear eccentric adjustment, and rocker arm is graduated to indicate length of stroke in inches. A large handwheel is provided for adjusting the position of the ram which is locked in position by a conveniently located binding lever. The crank gear has precision cut teeth for quiet operation. Oil impregnated bearings are used for both the crank gear and the countershaft. Pressure lubrication is provided by an automatic pump which circulates lubricating oil from a large reservoir in the base of the shaper to the ram dovetail, bull gear and pinion, pinion shaft and rocker arm shaft.

TOOL HEAD swivels to any angle, and has 3-1/2" diameter mounting with accurately cut graduations 0 to 90° right and left. The tool slide screw has a clear cut graduated collar reading in thousandths of an inch. The clapper box swivels on the tool slide and may be adjusted for clearance, regardless of the tool slide angle. A tool slide lock is provided so that extreme accuracy and flatness can be maintained.

TABLE has drilled holes and slots on top and on each side for clamping work. A V-groove is also provided on one side of the table. The cross-feed screw has a clear cut graduated collar reading in thousandths of an inch. The cross rail on which table slides is substantially constructed with large widely spaced bearing ways. Gib adjustment is provided for take up. Provision is made for locking the vertical adjustment. For safety, the cross-feed screw is so constructed that the nut will run off the thread when it has traveled the maximum distance in either direction. An adjustable front end support assures rigidity.

WISE swivels to any angle, with base graduated 0 to 90° right and left, and can be mounted on the top or right side of the table. Vise jaw inserts are made of heat-treated steel.

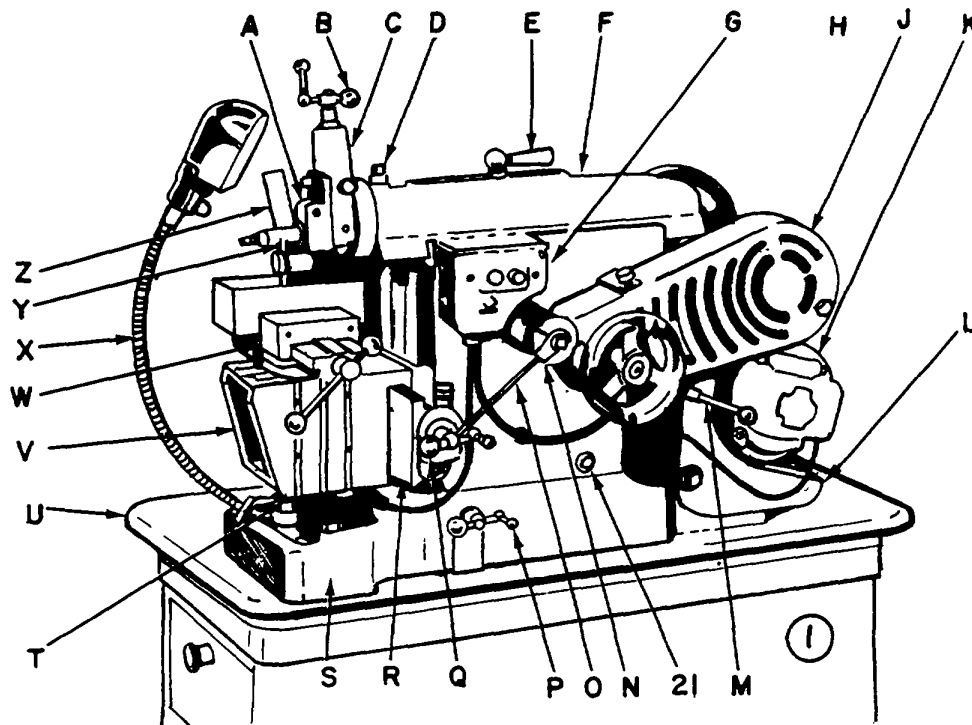

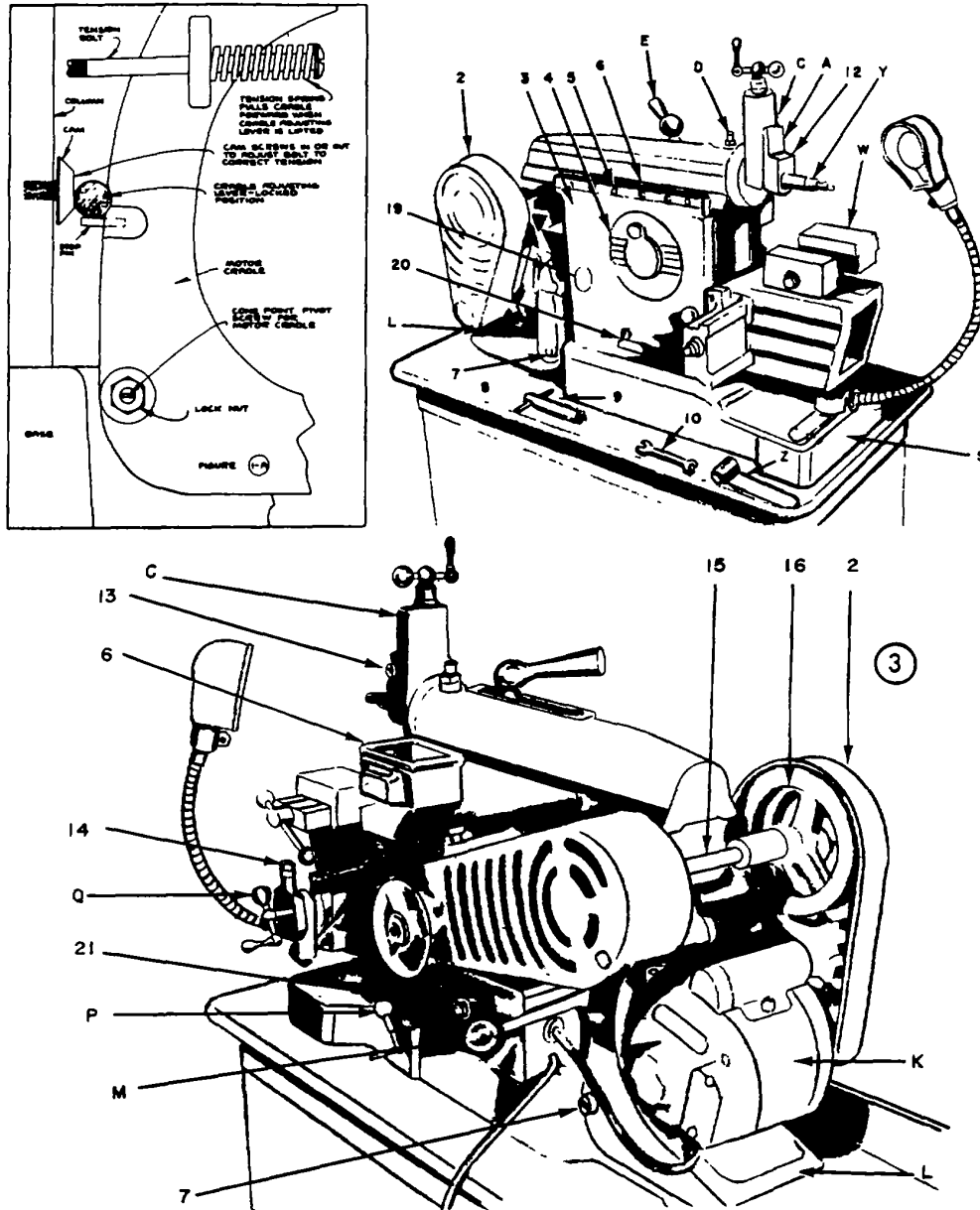

- | | | |
|---------------------------|---------------------------|---|
| A. Clapper Box | Q. Cross Feed Crank | 7. Motor Cradle Adj. Screw |
| B. Down-feed Handle | R. Cross-rail | 8. Elevating Lock Handle |
| C. Head | S. Base | 9. Ram Stroke Adj. Wrench |
| D. Head Swivel Lock Screw | T. Work-table Support | 10. Tool Post Wrench |
| E. Ram Clamping Handle | U. Support Locking Handle | 12. Clapper Block |
| F. Ram | V. Work Table | 13. Feed Lock Screw |
| G. Switch Box | W. Vise | 14. Feed Pawl |
| H. Hand Wheel | X. Lamp | 15. Counter-shaft |
| J. Drive-pulley Guard | Y. Tool Post | 16. Counter-shaft Pulley |
| K. Motor | Z. Tool Holder | 17. Counterbalance Adj. Screw |
| L. Motor Cradle | 2. Motor Pulley Guard | 18. Shaper Stand |
| M. Tension Release Lever | 3. Column | 19. Oil Pressure Regulating Valve Cover |
| N. Eccentric | 4. Cover Plate | 20. Oil Level Plug |
| O. Feed Rod | 5. Gib Adjusting Screw | 21. Oil Reservoir Drain Plug |
| P. Table Elevating Crank | 6. Gib | |

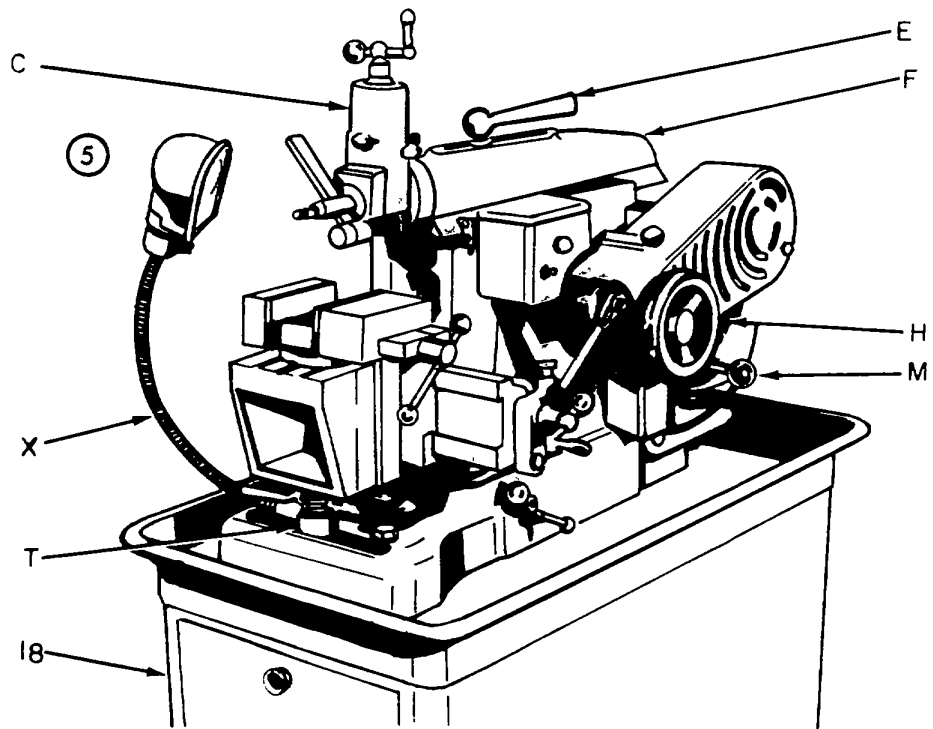
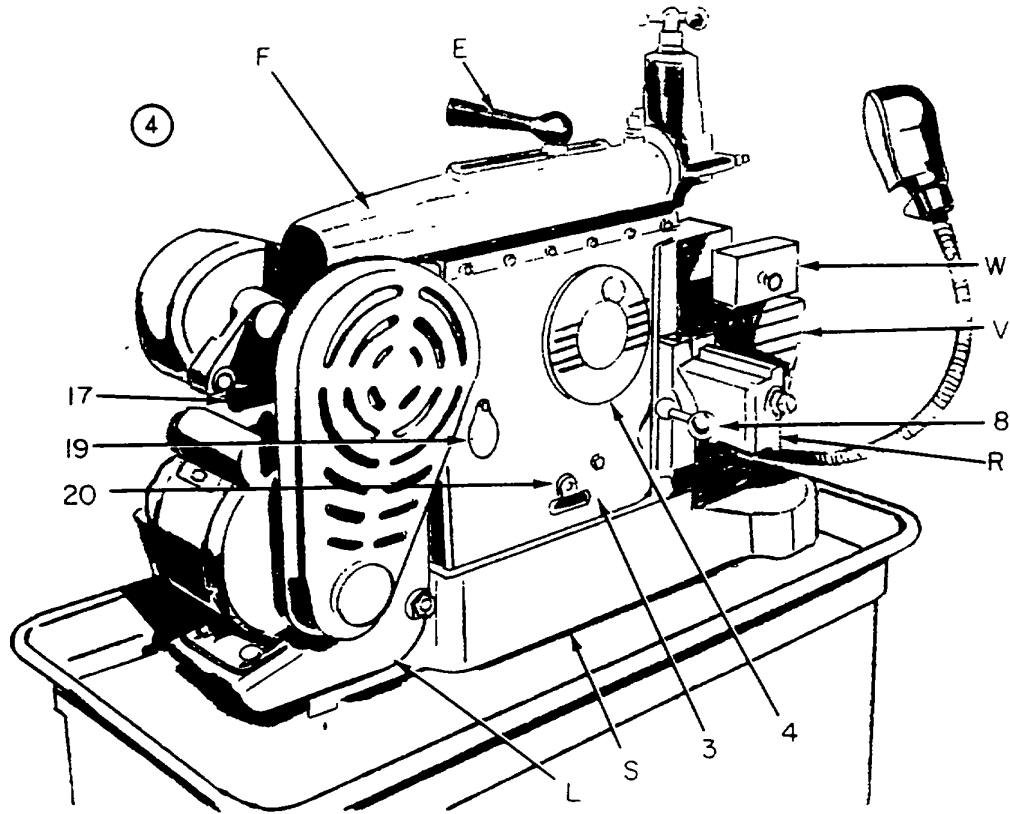

MOTOR required is 1/3 or 1/2 HP 1725 RPM, and is mounted on a cradle at the back of the shaper. Power is transmitted by V-belts. A quick acting belt tension release is provided for easy shifting of the belt to change speeds. All V-belts and pulleys are enclosed in substantial metal guards.

SPECIFICATIONS

RAM	Length of Ram Stroke	0 to 7"
	Strokes per Minute, approximate	42-75-120-195
	Cutting Speeds, approximate	3 to 114 ft. Per minute
TOOL	Vertical Travel	3
HEAD	Tool Post Takes Tool Holder Shank	3/8" x 13/16
	Swivels	3600
VISE	Width of Jaws	4
	Depth of Jaws.....	1
	Maximum Opening	4
TABLE	Length of Top	6 - 5/16"
	Width of 'Pop'.....	5"
	Depth of Table.....	5-3/8"
	Horizontal Travel	9-1/2"
	Vertical Travel	5"
	Distance from Ram	1/2" to 5-1/2"
	Power Cross Feeds (reversible).....	0.002" to 0.012"
	Width of Slots	5/16"
	Holes for Clamp Bolts.....	9/32"
MOTOR	Size Recommended.....	1/3 or 1/2 HP

SETTING UP AND LEVELING THE SHAPER

A new shaper should be very carefully unpacked and installed so that all of the fine accuracy that has been built into the shaper by the manufacturer will be retained.

Do not allow a hammer or crow bar to strike the shaper while unpacking, as this may cause serious damage. Look carefully in all packing material for small parts, instruction material, etc. Study reference books and instruction sheets carefully before setting up the shaper.

Clean the new shaper thoroughly with cloth and kerosene. Wipe with a clean cloth and immediately cover all unpainted surfaces with a film of good machine oil to prevent rusting. Wipe off the old oil occasionally and do not allow dust, chips or dirt to accumulate. Cover the shaper with plastic service cover or canvas when not in use. Keep the finished surfaces clean and well oiled and the shaper will retain its new appearance.

LEVELING

It is very important that the shaper be set on a solid foundation and that it is carefully and accurately leveled. For best results the shaper should be set on a concrete foundation. A wood floor should be braced to prevent sagging and vibration if it is not substantially constructed. The shaper may be leveled by placing shims of hardwood or metal under the lugs at the bottom of the stand.

Use a precision level and check both from side to side and from front to back across the work table.

Use lag screws or bolts to secure the shaper to the floor. Check the leveling of the shaper again after bolting it to the floor.

CUTTING TOOLS AND HOLDERS

A variety of types both in tools and tool holders can be used in the shaper. The straight-shank tool holder holds the tool parallel with the front and rear surfaces of the tool holder. As the tool is held parallel with these surfaces, it is at right angles to the direction of the stroke. Thus the clearance angles which are needed for cutting are easily determined and ground without having to take into consideration the inclined angle of the tool. With the adjustable head of the tool holder, the tool may be turned either to the right or the left, still maintaining the same attack angle to the work.

The shape of the tool varies considerably with the character of the work. To give examples of the various shapes of tools, for all purposes and at the same time to satisfy every individual mechanic's preference for form would be extremely difficult. There are certain principles, however, which the beginner must follow in order to use and grind cutting tools efficiently. The shape or form of the tool depends upon the shape of the cut, the kind of finish required, and the kind of material to be machined. The rake, the cutting angle, and the clearances, on the other hand, depend principally upon the nature of the material.

In order to more fully understand the grinding of cutting tools, study figures 7 and 8 showing the various terms to designate parts of a single-point cutting tool and the working angles used in grinding them. The following terms are accepted standards used in connection with shaper cutting tools.

POINT --The point is that part of the tool which is shaped to produce the cutting edges and face.

SHANK --The shank is that part of the tool on one end of which the point is formed or the bit is supported. The shank in turn is supported in the tool holder of the machine.

FACE --The face is that surface on which the chip rolls or flows as it is cut from the work.

CUTTING EDGE --The cutting edge is that portion of the face edge along which the chip is separated from the work. The cutting edge usually consists of --the side-cutting edge, the nose radius, and the end-cutting edge.

SHAPE --The shape of the tool is the contour of the face when viewed as presented to the work.

WORKING ANGLES --The working angles are those angles between tool and work which depend on the shape of the tool and on its position with respect to the work.

CUTTING ANGLES --The cutting angle is the angle between the face of the tool and the surface to the machined surface at the point of cutting. It equals 90° minus the true-rake angle.

LIP ANGLE --The lip angle is the included angle of the tool between the face and the ground flank measured in a plane at

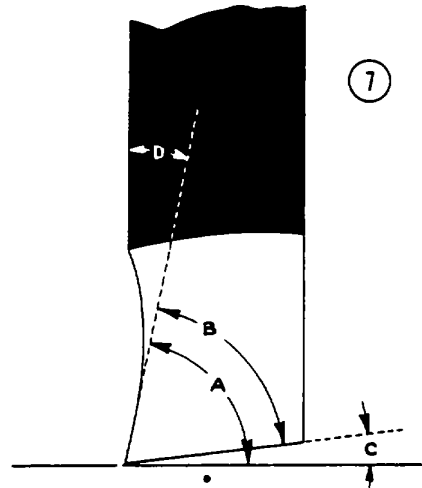
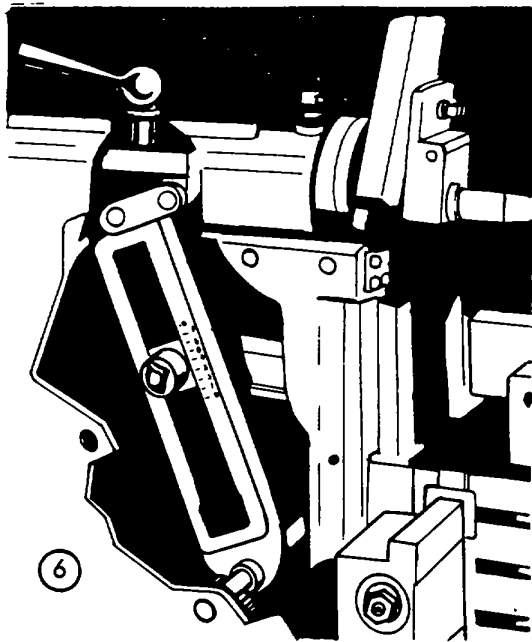

A - CUTTING ANGLE
B - LIP ANGLE
C - END RELIEF
D - BACK RAKE

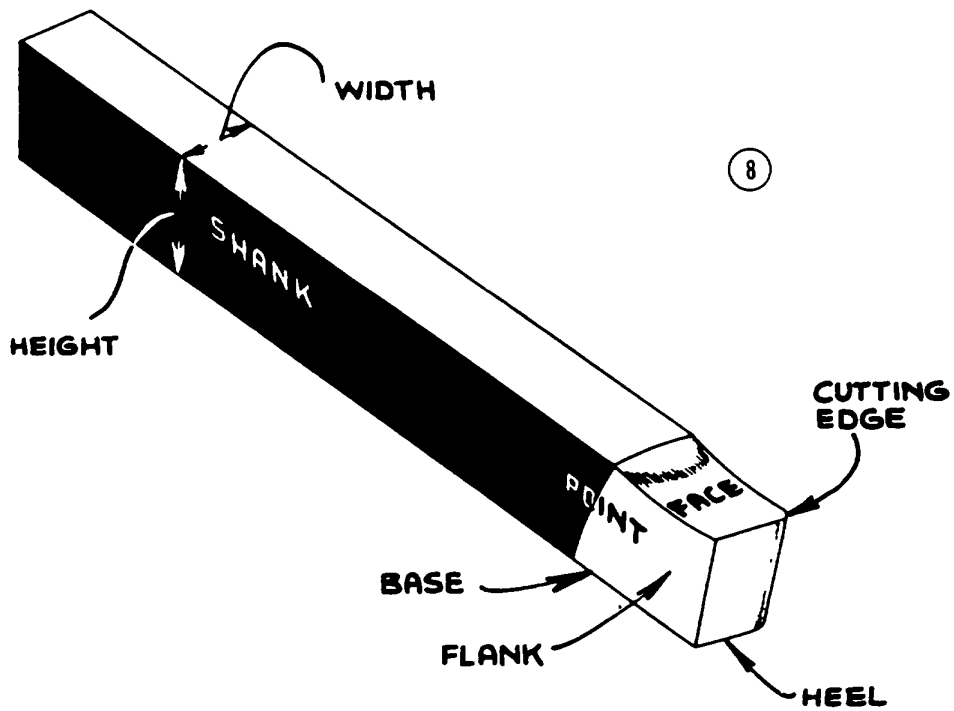

right angles to the cutting edge. When measured in a plane perpendicular to the cutting edge at the end of the tool, it is called the end lip angle. When measured at the end of chip flow, it is called the true lip angle.

BACK-RAKE ANGLE --The back-rake angle is the angle between the face of a tool and a line parallel to the base of the shank.

END-RELIEF ANGLE --The end-relief angle is the angle between the portion of the end flank immediately below the cutting edge and a line drawn through that cutting edge perpendicular to the base.

SIDE-RAKE ANGLE --The side-rake angle is the angle between the face of a tool and a line parallel to the base.

TRUE-RAKE ANGLE --The true-rake angle, under actual cutting conditions, is the actual slope of the tool face toward the base from the active cutting edge in the direction of chip flow. This, angle varies with the setting of the tool and with the feed and depth of cut.

RIGHT-CUT TOOL --A right-cut single-point tool when viewed from the face, has the cutting edge on the right side (fig. 10).

LEFT-CUT TOOL --A left-cut tool has the cutting edge on the left when looking at the false (fig. 9).

A bent tool has the point bent to the right or left to make its operation more convenient, see figures 11 and 12.

SHAPE OR FORM

The shape of the tool may be curved, flat, or its sides may converge to a sharp point. The shape or form of the tool will depend upon the surface being machined. For example, a tool with a curved form could not be used to produce a rectangular slot or a sharp corner. Neither would a tool with a sharp corner be recommended for a curved surface or for roughing a flat surface. See figures 15 through 20.

There is usually a difference between the roughing and the finishing tool. In addition, a tool may be offset, or bent to the right or to the left, and may feed either in a right-hand or left-hand direction, see figures 9 through 14.

A tool with a rounded nose may be used to rough out both steel and cast-iron surfaces, and with slight modification may be used to produce a finish cut.

A shear-cut tool is usually preferred for finishing steel (fig. 14) whereas, a tool with a flat end shaped as shown in figure 13 is extensively used to finish cast-iron.

ACCURATE MEASUREMENTS

Careful and accurate measurements are essential to good machine work. The ability to take accurate measurements can only be acquired by practice and experience. All measurements should be made with an accurately graduated steel scale or a micrometer. Never use a cheap steel scale, or a wood ruler, as they are likely to be inaccurate and cause spoiled work.

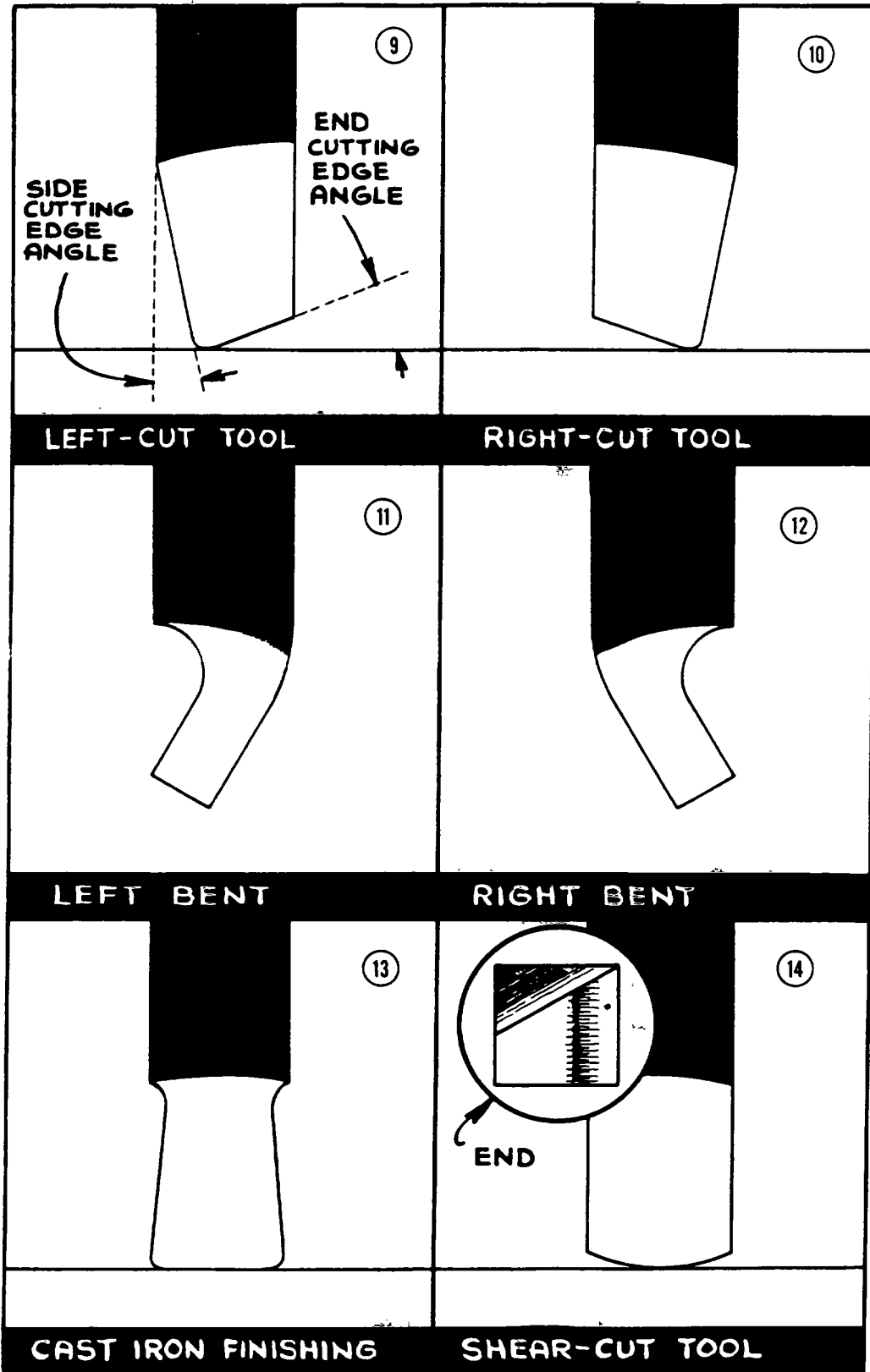

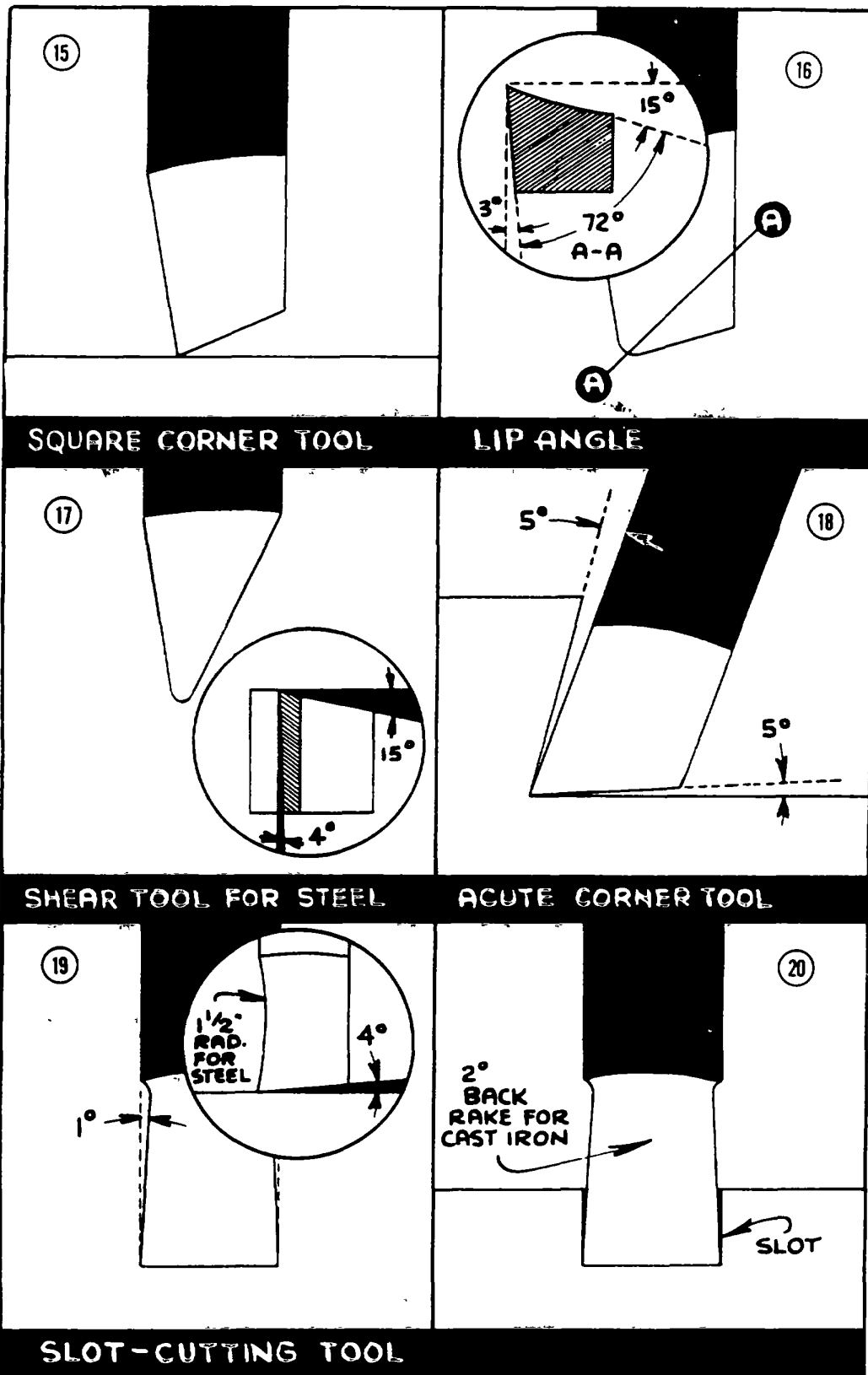

SQUARE CORNER TOOL

LIP ANGLE

SHEAR TOOL FOR STEEL

ACUTE CORNER TOOL

SLOT-CUTTING TOOL

An experienced mechanic can take measurements with a steel scale and calipers to a surprising degree of accuracy. This is accomplished by developing a sensitive "caliper feel", and by carefully setting the calipers so that they "split the line" graduated on the scale.

MOUNTING THE WORK

The table has been designed so that work can be set up in the shaper with comparative ease. The table has three slots in the top parallel with the ram. The left side of the table also has three slots which are parallel with the ram. The right side of the table has two square slots and one V-slot which are vertical or at right angles to the ram. The V-slot is for mounting round work vertically against the side of the table. All of the square slots are drilled for clamping purposes. All of the slots are generally used when the size or shape of the work prohibits the use of the vise. A hole is provided in the top and in the right side of the table for mounting the vise. The vise is fastened to the table by means of a stud bolt. The vise is provided with a swivel base which is graduated for exact angular setting to either the right or left. A key way in the base of the vise when used in conjunction with a key and the slot in the table makes it possible to lock and clamp the vise in an exact 90° position (fig. 21).

To hold reasonably square or rectangular work in the vise presents very few problems. There are several methods which when followed will assure the operator of obtaining a reasonably accurate job of machining. One method is shown in the following figures. Open the vise jaws to the approximate width of the work and lay a small strip of paper in each corner between the jaws as shown in figure 22. Place the work carefully in position (fig. 23) and tighten the jaws snugly onto the work. Now, test each corner by checking to see if the four strips of paper are held tightly under the work (fig. 24). If one corner is high, tap sharply with a soft metal mallet as shown in figure 25, at the same time, tighten the jaws of the vise securely on the work. This will insure that the work is seated firmly in the vise. If the machining should be begun and the work shifts because of faulty clamping an inaccurately machined surface will result.

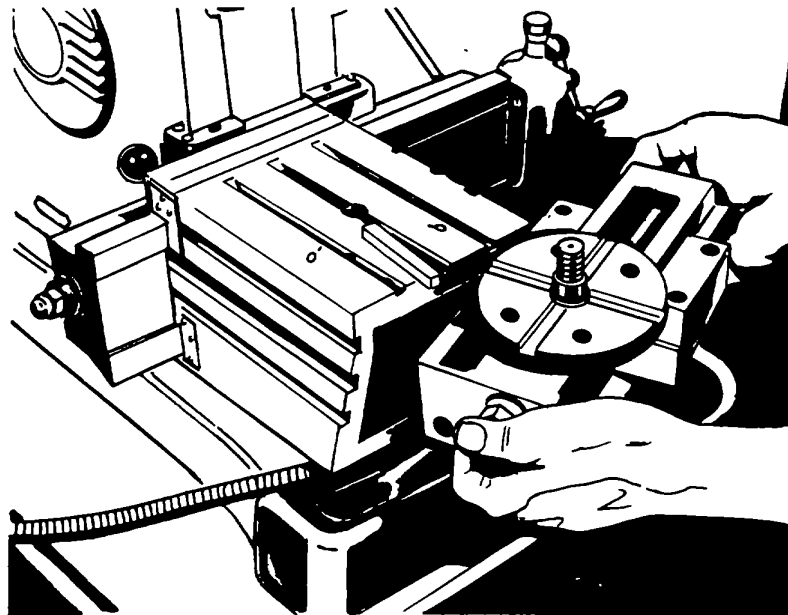

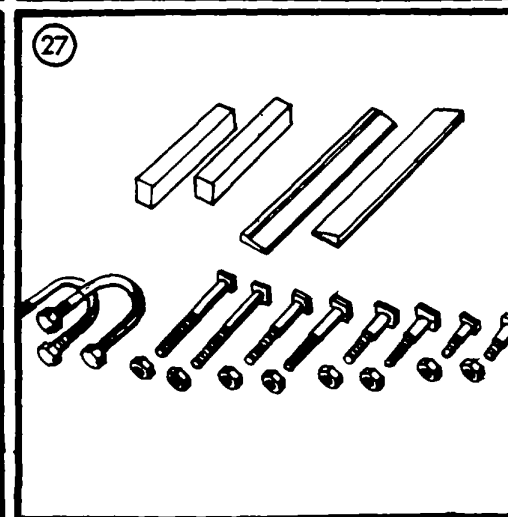
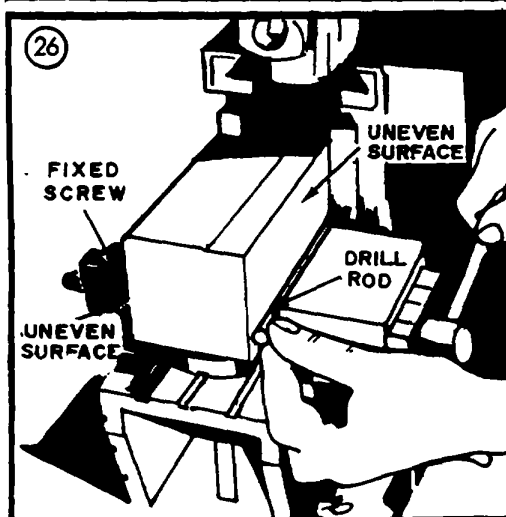
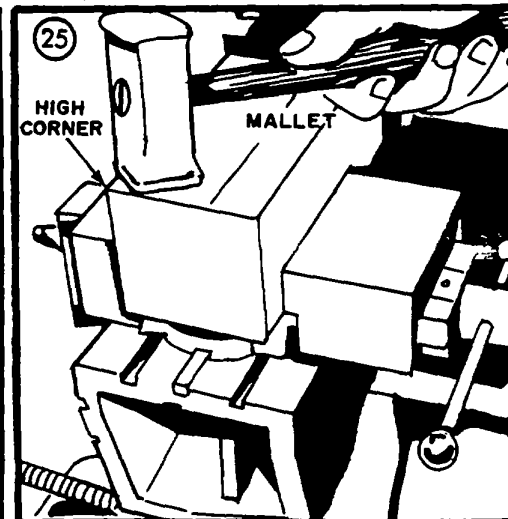
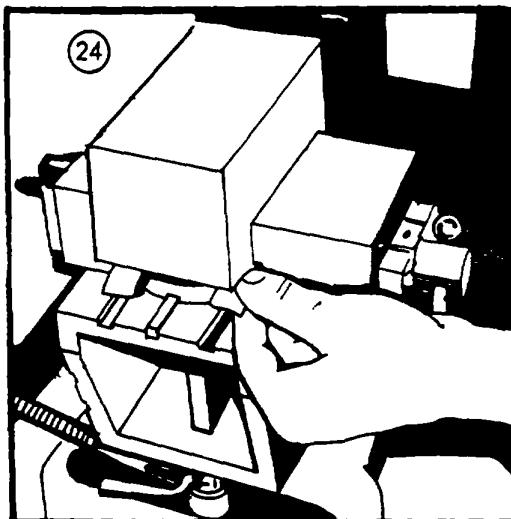
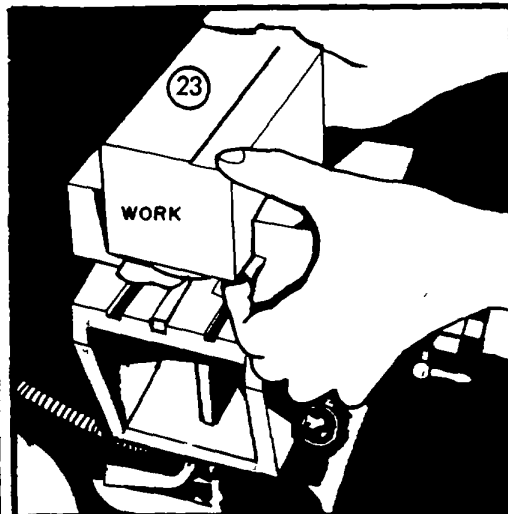
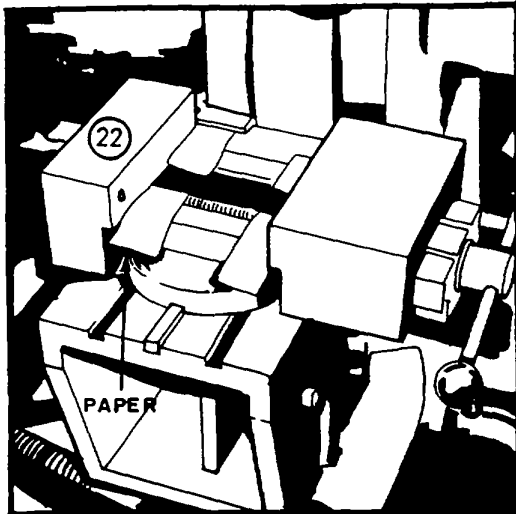

If one side of the work to be clamped in the vise is tapered or otherwise too rough for the jaw of the vise to hold securely, one method is to place the good or flat side against the fixed side of the vise and use a length of drill rod against the rough or inaccurate surface of the work as shown in figure 26.

There are various other devices, parallels, hold downs, T-bolts, etc. which are used in clamping work in the shaper both with and without the use of the vise. Several of these devices and fixtures for mounting, clamping, and hold down, are shown in figure 27.

ADJUSTING THE SHAPER

Some adjustments must be made to the shaper before it is ready for operation. Some of these adjustments will be described here while others will be brought up as it becomes necessary in the operation procedure.

One of the first adjustments is to check the adjustment of the gib along the ways of the ram. Check this adjustment as shown in figure 28. There should be no side play in the ram, yet it should slide freely back and forth in the ways. If too much play is evident, adjust as follows; loosen the lock nuts on the gib screws (fig. 29) and then tighten by turning in the hexagon socket head gib screws starting with the ends first and working in to the middle. Turn the screws up until they are snug; do not use pressure. Retighten the lock nuts and again check the ram. Make sure that it travels freely .

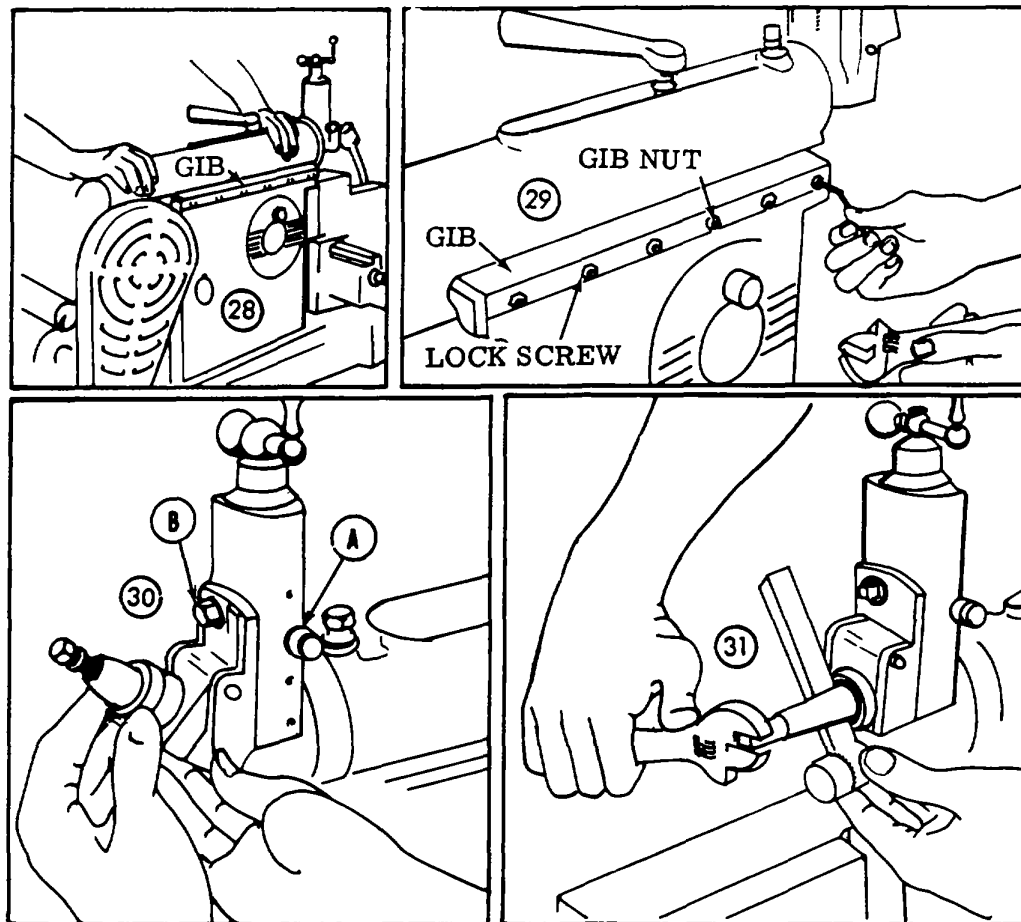

OPERATION

Certain rules are essential in setting up a job in the shaper. Whenever practical, move the cross rail up on the column so that the surface to be machined is about two inches below the ram. With the tool held as short as is practical, and the head centered in front of the ram, you will avoid excessive overhang and thus avoid undue stresses on all parts of the head, tool post, and tool holder. The tool holder should be held as close to the vertical as possible whenever the cut permits. If it becomes necessary to turn the tool holder to one side or the other the angle should therefore be as small as possible.

The shaper tool is held in a tool holder, which in turn, is clamped in the tool post. The tool post is inserted in the clapper block as shown in figures 30 and 31. The clapper block fits snugly against the sides and the back of the clapper box and is held in place with a hinge pin. Thus the clapper block will not move perceptibly during the cutting stroke, but will lift readily on the return stroke. This prevents the cutting edge of the tool from being broken on the return stroke. The clapper box is attached to the tool-head which in turn is fastened to the front of the ram. The tool head travels vertically on dovetailed ways and the entire unit may be swiveled 360° for cutting at any angle. The vertical travel of the head may be locked at any point by means of a knurled screw (A, fig. 30). The swiveling of the head is regulated with a graduated scale and is locked in any position by means of the square head lock-screw (B, fig. 30).

The position of the stroke is regulated and locked by means of the ram clamping handle (E, fig. 1). The length of the stroke, which will be described later is adjusted by removing the cover plate on the side of the column shown in figure 2.

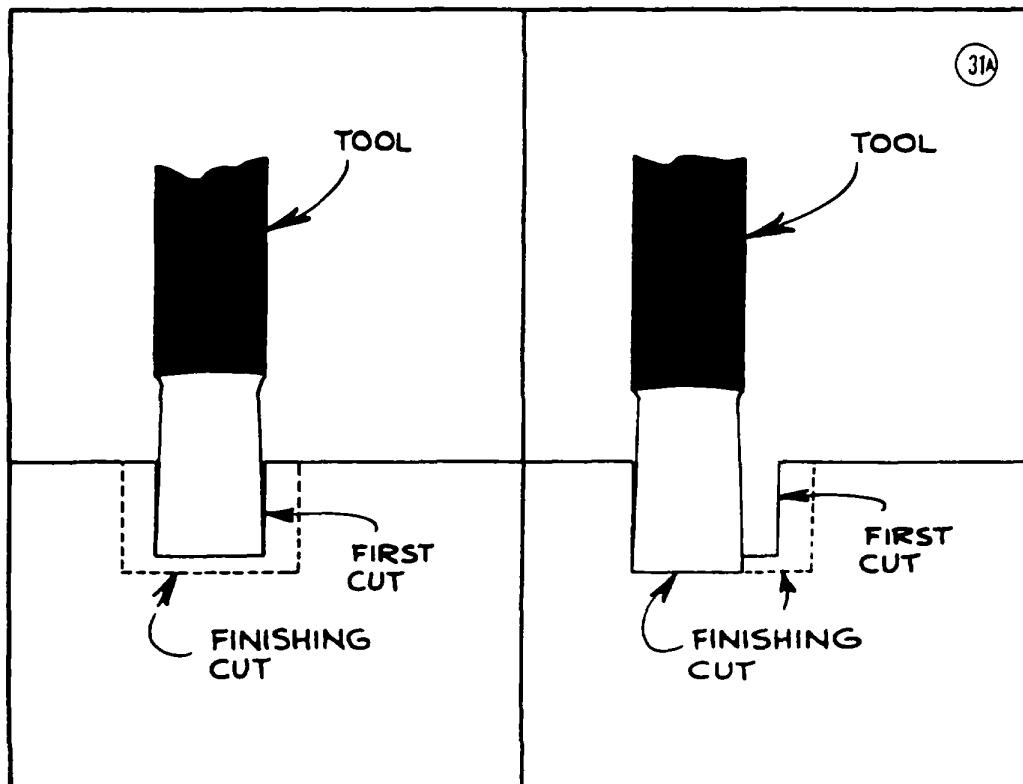

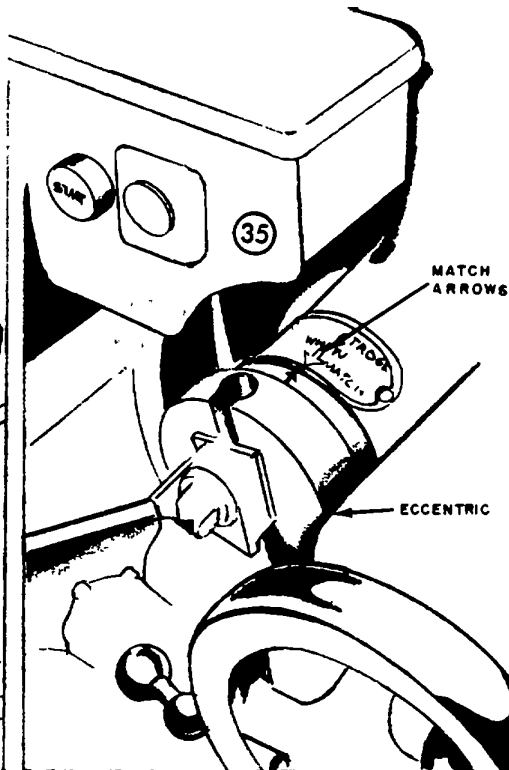
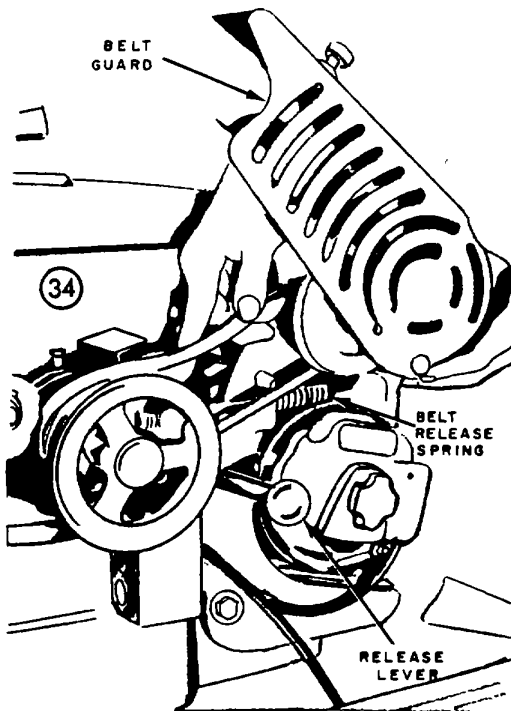
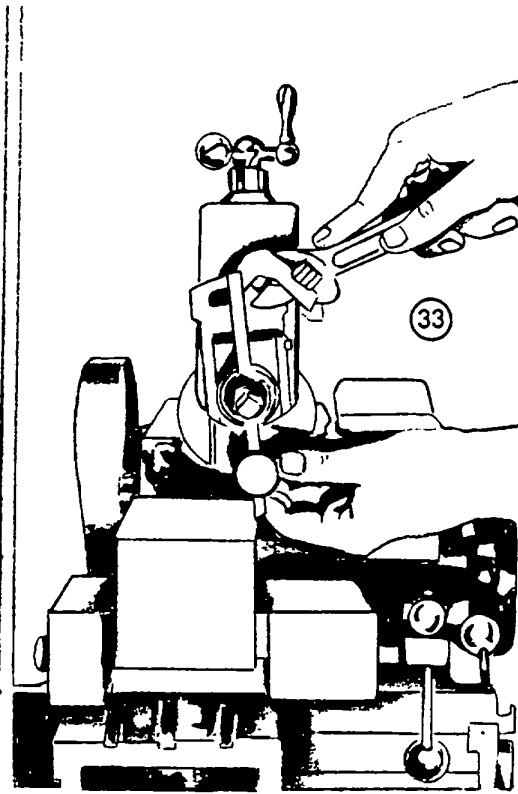
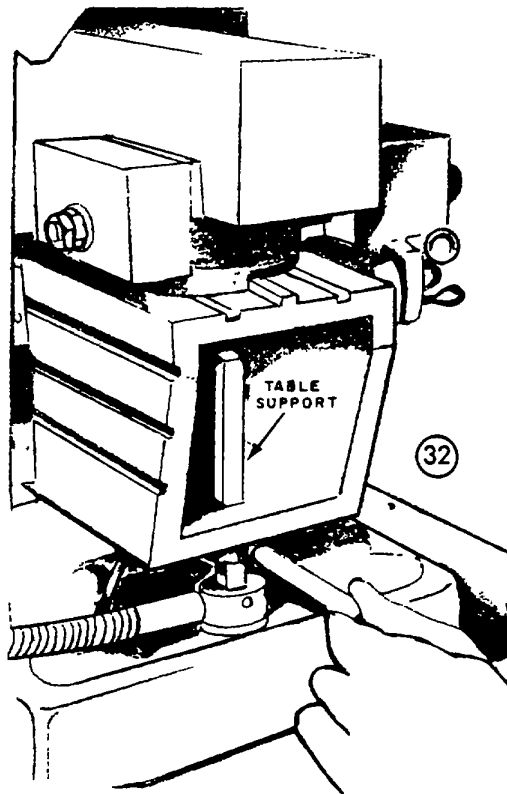

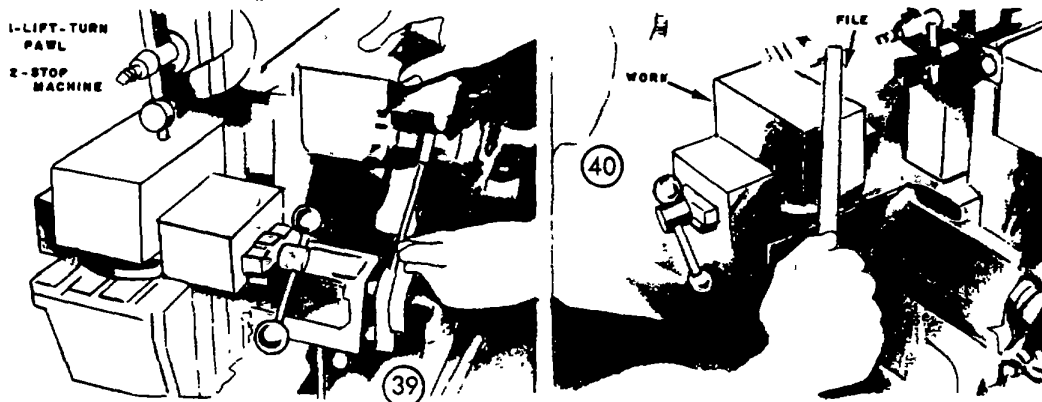
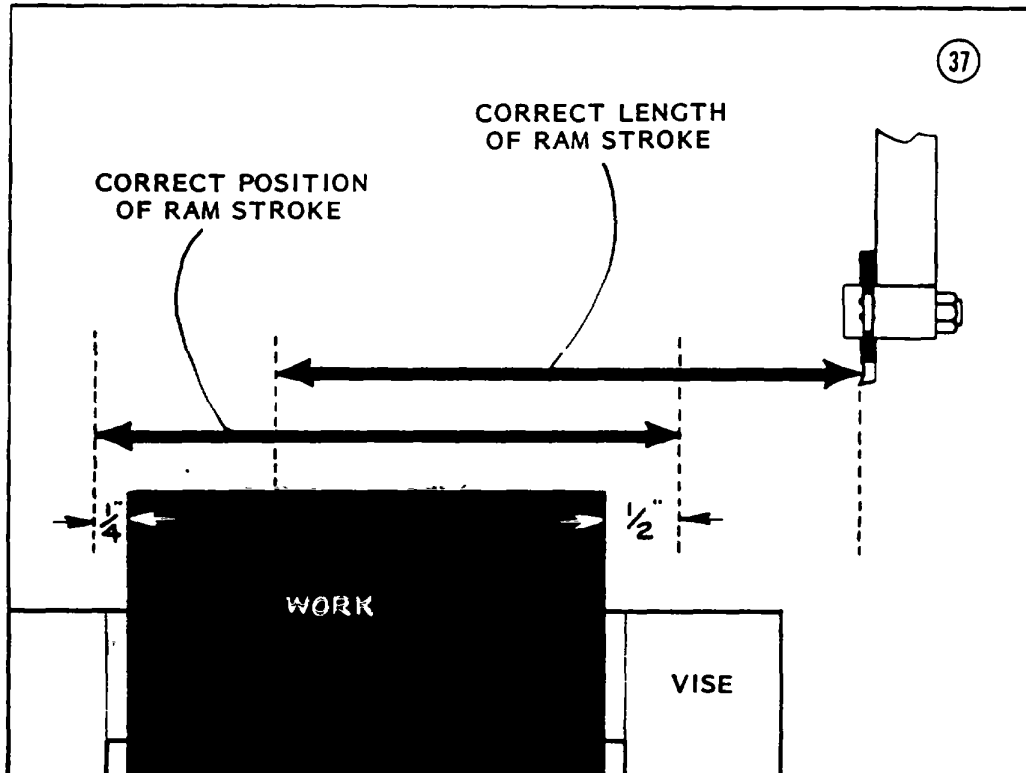
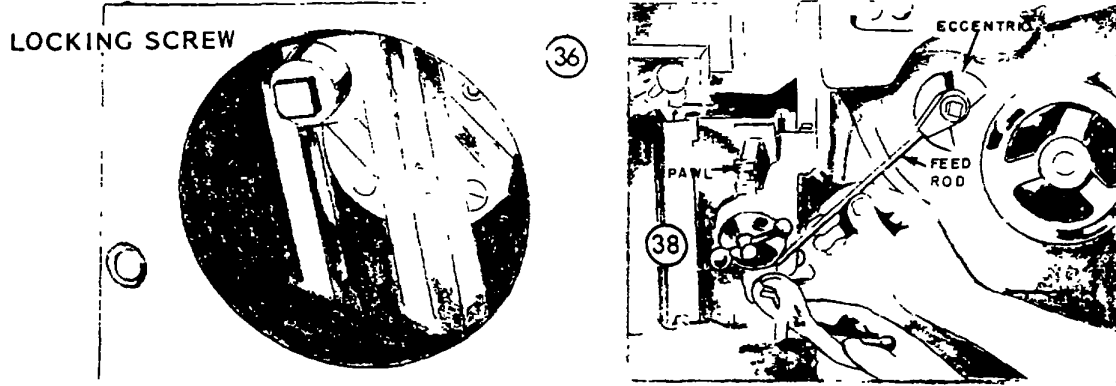

The table travels horizontally on a cross rail (R, fig. 1) and vertically on dovetailed ways on the front of the column (3, fig. 2). The vertical travel of the table is regulated with the ball crank (P, fig. 1) and is locked in any given position with the lock handle (8, fig. 4). The horizontal travel of the table may be operated by hand with the ball crank (Q, fig. 1) or automatically by means of the feed rod (O, fig. 1). The automatic feed may be engaged or disengaged by means of the pawl (14, fig. 3). The arrow on top of the pawl indicates the direction the table will travel automatically when the pawl is engaged.

The table support (T, fig. 1) is always lowered against the machined surface on the base and locked in position with the locking handle (fig. 32). The flexible stem of the work lamp is fastened to the table support and the lamp cord is plugged into the receptacle on the bottom of the switch box (fig. 1). The switch box contains an on and off push button switch for operating the shaper and a toggle switch for operating the work lamp.

The clapper box should be tilted by releasing the lock screw as shown in figure 33 and moved in such a way that on the return stroke of the ram the clapper block lifts up and away from the work being cut.

The hand-wheel (H, fig. 1) is used for checking and adjusting stroke position, and should always be used to operate the ram for one complete stroke before turning on the power, thus, avoiding any mis-adjustment which may result in ram ways striking the vise, work, etc.

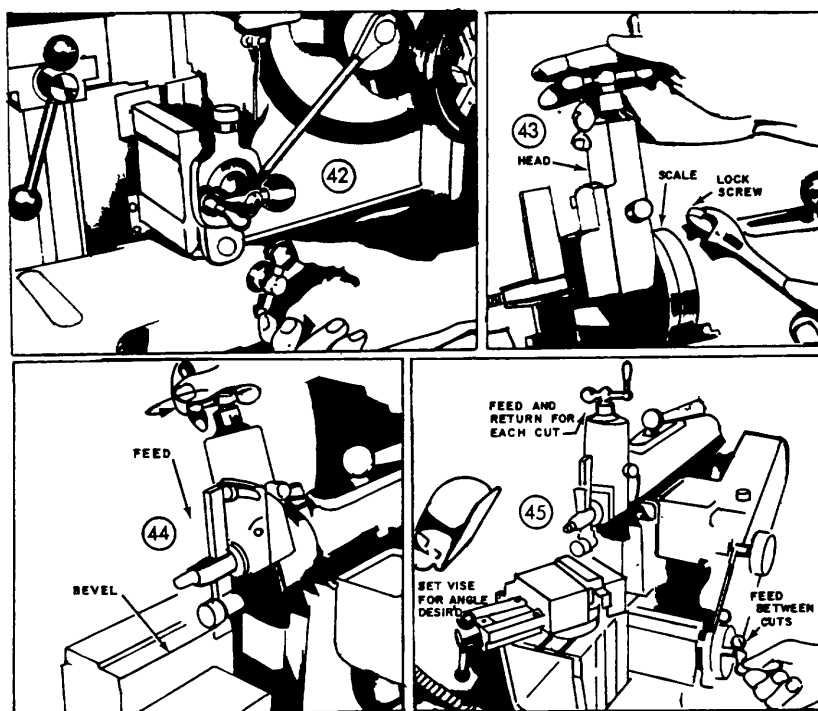

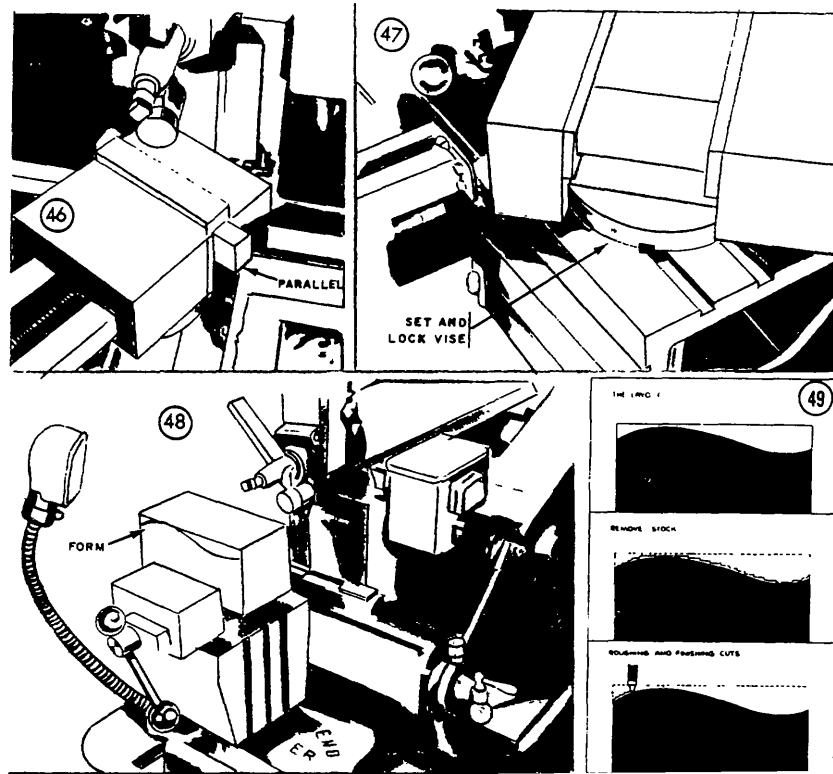

The motor is mounted on a pivoted cradle (L, fig. 1) and power is transmitted to a shaft and from there to the drive mechanism. Belt tension is adjusted by turning the cam in or out as shown in figure 1-A. The belt tension is released for changing the belt on the four step pulleys by lifting the lever (M, fig. 1 and fig. 34).

The entire shaper may be mounted on a three drawer steel cabinet. The top surface of the cabinet forms a tray or built-in chip pan. The drawers are provided with locks for storage of work, tools, and accessories. The cabinet should be bolted to the floor for elimination of vibration and excessive noise.

The first step after the work is mounted is to adjust the length of the stroke. The length of the stroke is regulated by the width of the work to be machined plus 1/4 inch at the end of the stroke and 1/2 inch at the beginning of the stroke (fig. 37). The 1/4 inch which the cutter travels over the end of the stroke allows ample chip clearance. The 1/2 inch at the beginning of the stroke allows the clapper block to drop back into its normal position for the beginning of the next cutting stroke. The first step in adjusting the length of the stroke is to turn the handwheel until the two arrows line up as shown in figure 35. Next, remove the cover plate from the left side of the column and loosen the square head locking screw (fig. 36). The graduated scale is marked off in inches. Move the sliding block, set the marker at the correct length and retighten the screw. Replace cover plate.

The stroke is now adjusted to the correct length--it may not however be regulated to the correct position. The ram must be located so that the stroke covers the work, (fig. 37). To do this, loosen the ram clamp handle in the upper slotted part of the ram. This will allow the ram to move to the desired position. To locate this position, turn the shaper with the handwheel until the crank is at its extreme forward position. Now, loosen the ram clamp handle and set the ram so that the tool clears the work by 1/4 inch. When this correct position of the ram has been reached, tighten the ram clamp handle.

The work is now mounted in the vise. The stroke has been adjusted for both length and position. You are now ready to set the horizontal travel for automatic feed.

Generally speaking a coarse feed is used for roughing cuts, while a fine feed is used for finishing. Set the eccentric (fig. 35) for a feed of approximately 0.004 by releasing the-locking screw, moving the feed rod with its graduated scale to the correct position and retightening the screw. Now, with the eccentric slot in a vertical position, loosen the setscrew releasing the lower end of the feed rod, and line up the feed pawl casting holding the horizontal feed pawl and gear. Turn it into position so that it is vertical and parallel to the slot in the feed crank. Retighten the setscrew locking the feed rod in position (fig. 38).

The scale on the eccentric is graduated in both directions from the center. This is necessary so that the horizontal travel can be regulated on the back stroke whether the table is traveling from left to right, or from right to left. The automatic feed must be set in this eccentric so that the ball crank advances while the ram is in its backward stroke. When it is correctly adjusted, the pawl lifts on the spring while the ram is in its forward or cutting stroke--engages the teeth and advances the ball crank when the ram is in its backward stroke. If this is incorrectly adjusted the table would be moving sideways as the tool is advancing in its cutting stroke. When changing from a left cut to a right cut the feed must be changed to the opposite side of dead-center in the slot of the eccentric.

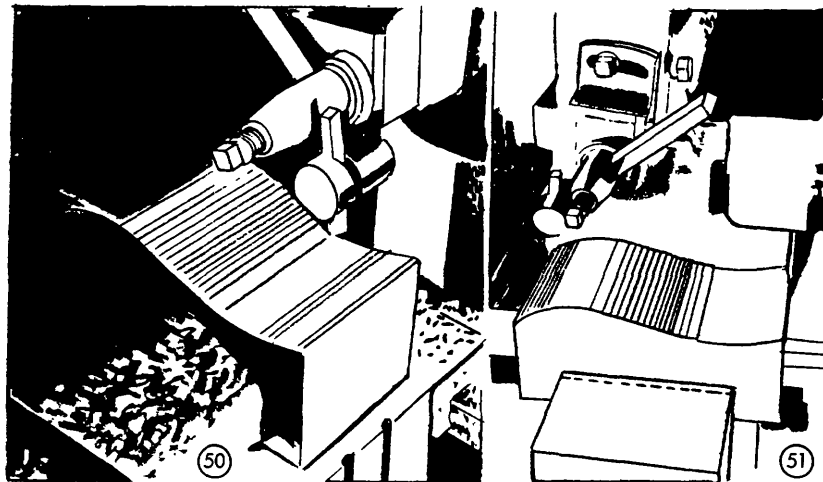

The arrow engraved in the top of the pawl indicates the direction which the work table will automatically travel when the automatic feed is engaged. When the pawl is lifted and turned so that the arrow points toward the handwheel the table may be moved back and forth on the cross rail by means of the ball crank. Assuming that you have a left cut tool in the tool holder crank the work over on the cross rail until the work is on the left side of the cutter. Move the cutting head down to the surface of the work and lock into position with the knurled lock-screw on the side of the head. The table support should be lowered and locked in contact with the machined surface on the base casting, figure 32. This surface should have a light coat of machine oil and should always be kept clear of metal chips. With the cutting tool slightly to the right side at the beginning of the work turn the cutter head down to the amount of feed desired using the graduated dial beneath the ball crank to obtain the correct depth.

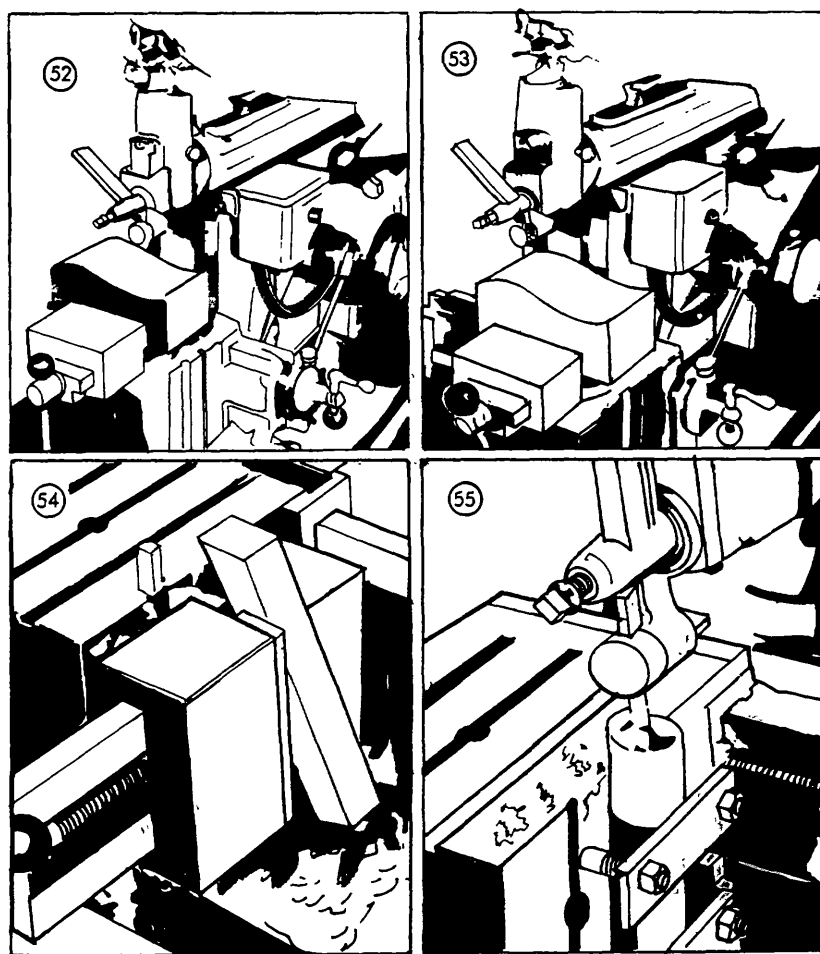

Lift and turn the pawl so that the arrow points in the direction of the proposed feed, in this case from left to right. Turn the handwheel making a complete stroke, forward and back, to make sure that everything is clear and in order that the ram does not strike the work. You are now ready to start the machine and make the first surface cut on the work.

If it becomes necessary at any time during the surfacing or machining of the work to stop the machine while it is still cutting, first lift the pawl disengaging the automatic feed (fig. 39) before stopping the machine. This will avoid stopping the ram in the middle of a cutting stroke which could damage the cutting edge of the tool.

THE ROUGHING CUT

A roughing cut is one made primarily to prepare the surface of the work for a final or finishing cut. The appearance of the surface is of minor importance. Roughing cuts may consist merely of taking one or more cuts in order to remove irregularities on castings leaving the surface fairly straight and level, or preparing it for a finishing cut. Roughing cuts may consist of several heavy cuts when excess metal is to be removed from the surface.

The edge at the end of the cut, especially on cast materials, is likely to break off leaving the edge ragged. This condition can be avoided by beveling the edge, using a file as shown in figure 40. Shaper must not be in operation when this is done.

THE FINISH CUT

The finishing cut is one made for the purpose of machining the work to size and at the same time giving it a good smooth surface.

The amount of material which must be removed in a finishing cut is dependent upon the surface left by the last roughing cut. Ordinarily between ten and fifteen thousandths is left for removal with the finishing cut.

THE VERTICAL CUT

Vertical cuts are used for squaring the ends of long cuts, for squaring shoulders, and for cutting slots in keyways etc. , (fig. 31-A).

There are two ways in which a vertical cut may be shaped. First, and most frequent, the tool is fed to the work in a downward direction by means of the down feed screw. In the second method, the work is fed to the tool, by means of the table elevating screw, (fig. 42). When using this second method be sure that the work is not elevated too far so that it is struck by the ram.

THE BEVEL CUT

The most common method of producing an angular or bevel cut is to swivel the tool head and produce the bevel by feeding in an angular direction with the down feed crank.

The tool head is swiveled by releasing the lock-screw (fig. 43) and turning the head to the desired angle using the graduated dial as shown. Retighten the lock-screw. The tool is then fed by turning the feed handle as shown in figure 44.

OTHER CUTS

Besides horizontal, vertical, and angular cuts, the shaper is often used for a variety of slotting, serrating, and simple form cutting.

A slot may be cut to any width; the sides of the slot may be straight or sloping. A tool may be ground to the exact width of the slot and then used to cut the slot in one operation. If the slot is wider than the tool, the tool can be set down to cut one side of the slot first. When this side is cut, the tool can be raised, the work moved over the correct distance, and the tool fed down to complete the second side of the slot. Another method is to make a roughing cut leaving excess stock at both sides and bottom. A finishing cut is then made as shown in figure 31A.

Serrating is the process of cutting a series of equally spaced grooves upon the surface of a job. Serrating may consist of two sets of grooves which cross each other and leave small regularly shaped areas between cuts. Figures 45 and 46 illustrate a serrating job. The work was mounted with a parallel block underneath for support and to raise the surface of the work above the jaws of the vise. The vise was first swiveled 30° to the right and clamped in place, (fig. 47). The slots were equally spaced by means of the graduated dial on the cross feed handle. The depth was regulated by the graduated dial on the down feed handle. The vise was then swiveled 30° to the left and the second series of grooves were cut. This resulted in a series of diamond shaped areas with 60° sides.

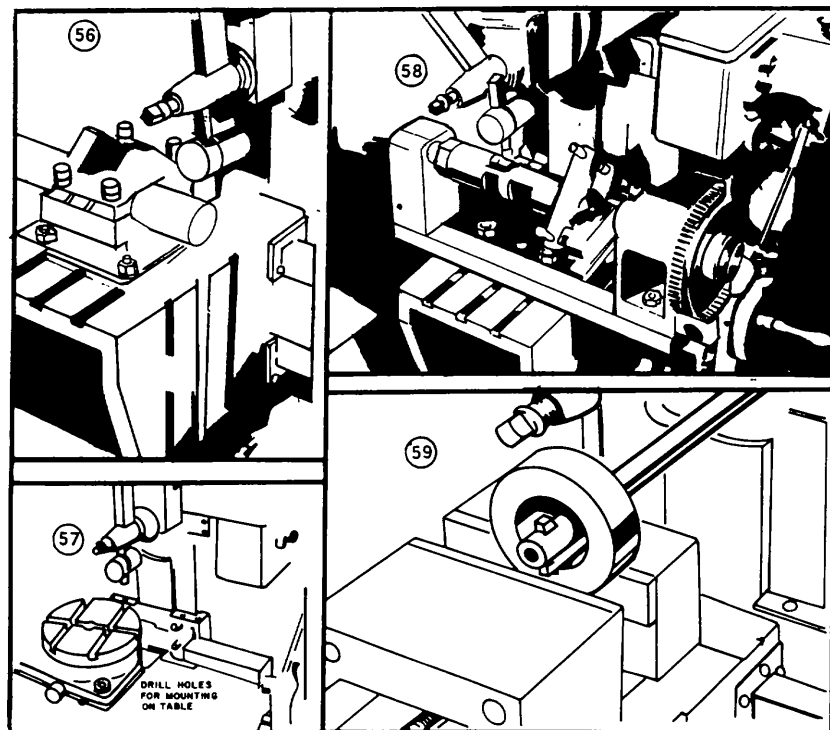

Contour or form cutting, indicates a curved surface or outline. Often the form of the contour is laid out on the end of the work. An example of contour cutting is shown in figure 48. The steps used in cutting the contour pictured are shown in figure 49.

The first step is to make a series of horizontal cuts using the automatic feed and removing excess metal as shown in figure 50. A left hand cutting tool was used to remove the metal on the right side of the work. A right-cut tool was used to remove the excess metal at the left side of the work as shown in figure 51.

A V-shaped cutting tool with a round nose was then clamped in the tool holder and a roughing cut made as follows; the table was moved in order to start the roughing cut at the right end of the work. The automatic feed was set so that the horizontal travel was relatively slow (approximately 0.002 per stroke). The belt was moved to the pulley step giving the lowest stroke speed. With the horizontal travel regulated automatically the operator now follows the contour of the work by gradually feeding the vertical feed crank up and down as the work travels across under the cutting tool. With a little practice and the machine slowed down the operator will find this process not as difficult as it first appears (figures 52 and 53).

After one or two light roughing cuts the cutting should have progressed to a fairly accurate line so that a finishing cut is now possible. If the curve of the final contour is fairly slow, the finishing tool may be ground to a more blunt curve allowing a more gradual slope to the finishing strokes.

SPECIAL CLAMPING JOBS

A hole is provided in the side of the work table for the vise stud so that the vise may be secured in the position shown in figure 54. Odd shaped castings or special setups may thus be made positioning the work under the cutter head where excessive over-hang might otherwise have been found objectionable.

Round work may be mounted vertically making use of the V-slot in the side of the work table, clamping plates, and bolts. The work is thus held securely for end machining operations (fig. 55)

ACCESSORIES

Various other accessories, jigs, and special fixtures are used for clamping specialized work to the work table of the shaper for machining operations.

Accurately machined V-blocks may be used to hold round stock securely in position for machining to various shapes, bevels, etc. (fig. 56) The rotary table with its T-slots for clamping is efficient and accurate for machining serrations, grooves, and hundreds of other beveling and machining operations at various angles from the standard stroke direction (fig. 57) The indexing head as shown in figure 58 is extremely efficient and practical for a wide variety of specialized shaper operations.

The extension shaper tool holder shown in figure 59 is a rigid tool for internal work. It is well adapted for internal die work, internal keyways, or for any work on the shaper in which extra clearance is needed. You will notice that the head is adjusted so that the rear of the extension goes into the opening at the top of the column on the return stroke of the ram. Adjust the head carefully and check with the hand wheel before turning on the power.

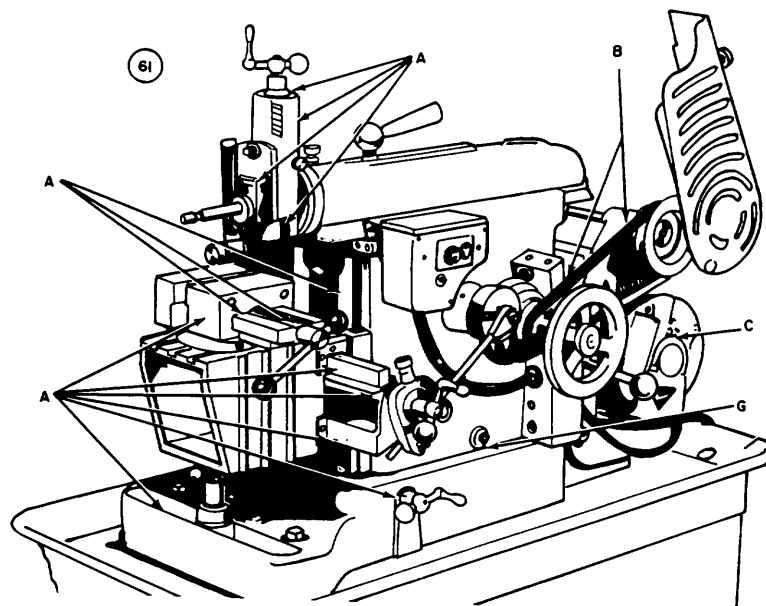
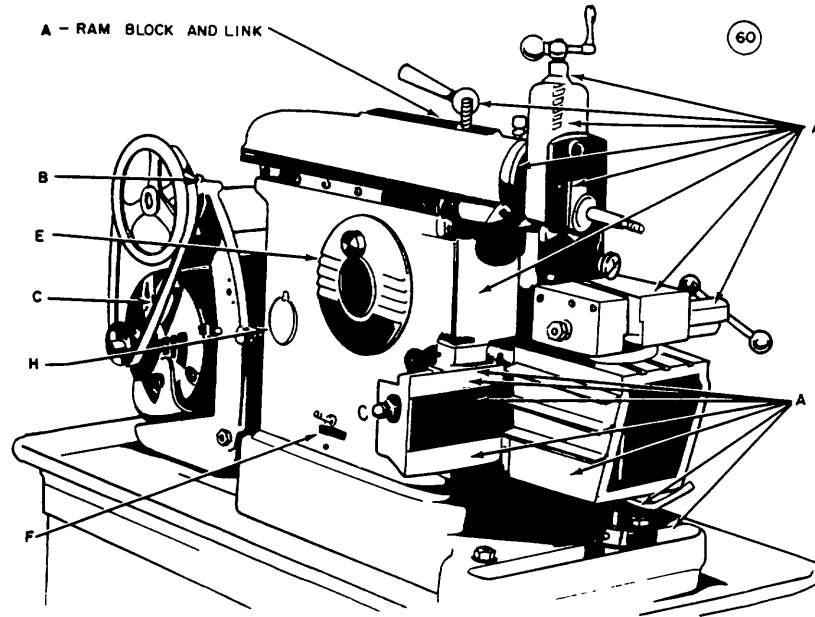

LUBRICATION OF SHAPER

Automatic lubrication of the bull gear, ram, rocker arm shoe and other important bearings is provided by an automatic pump which circulates oil through tubes leading from the oil reservoir in the base of the shaper to the various bearings. Oil holes are provided for manual lubrication of other bearings. Before operating the shaper, always make sure the oil reservoir is filled to the level indicated and the pump is circulating the oil properly.

OIL RESERVOIR

To fill the oil reservoir, remove cover plate E , figure 60, and oil level plug F . Pour oil in until it starts to run out of oil level hole. About one quart will be required. Use medium weight machine oil Saybolt Universal viscosity approximately 200 seconds at 100° F. Do not use automobile engine oil or other oil which may contain a detergent. When oil in reservoir becomes dirty, remove drain plug G, (fig. 61), drain and flush thoroughly, replace drain plug and fill reservoir with fresh oil.

OIL PUMP

The oil pump is properly adjusted at the factory and no readjustment should be made as long as it functions properly. However, if flow of oil is excessive or insufficient, adjust as follows:

1. Fill reservoir with correct grade of fresh oil.
2. Set shaper for maximum stroke at slowest speed.
3. Let shaper run idle for 30 minutes.
4. Recheck flow of oil and if necessary regulate with flow adjusting valves directly opposite opening H in shaper column. Use a screwdriver to turn valves. Valves are in maximum open position when screwdriver slot is vertical.

MANUAL LUBRICATION

All shafts, flat bearing surfaces, feed screws and other bearings not lubricated automatically should be oiled manually at regular intervals as indicated in chart below. Same oil as specified for the oil reservoir may be used.

LUBRICATION CHART (fig. 60 and 61)

KEY	DESCRIPTION	PERIOD
A	Ways, shafts, feed screws, machined surfaces	Daily or before each period of use
B	Countershaft and Belt Tension Release Cam	Once each week
C	Motor	Follow motor manufacturer's instructions

GENERAL MAINTENANCE

It is important that a good maintenance program is conducted to assure long life to any machine. The following are recommendations for proper maintenance.

The shaper is equipped with way wipers on the cross and vertical ways of the shaper knee, ram and tool slide. Periodically the wipers should be inspected and cleaned. Their function is to trap chips from entering between the ways. If a chip works its way past the wipers and gets between the way surfaces, scoring will occur.

I. Steps for cleaning wipers, gibs, and ways.

1. Remove the retainers and felt wipers, items 4, 6, 49 and 50 (Page 35).
2. Wash retainers and wipers in clean solvent.
3. Back off gib lock nuts and adjusting screws, items 42 and 55 (Page 35) and remove gib.
4. Wash gib in clean solvent. If any evidence of imbedded chips is present, remove and clean surface.
5. Clean slide area with solvent and repeat procedure for removing any imbedded chips if found on slide surface.
6. Oil slide surface and gib. Replace gib.
7. Adjust gib adjusting screws by starting at each end and working towards the center. Adjust all screws until they are snug, not tight. Check slide movement for free movement with no side play. When this is accomplished, tighten lock nuts while holding adjusting screws from turning for positive adjustment.
8. Reinstall retainers and wipers.

SHAPER REPAIR INSTRUCTIONS

Item numbers listed in the following instruction sheet will be found on Parts List for Column and Base on page 32 unless otherwise specified.

To Remove Ram from Shaper:

1. Remove ram block handle, item 1; spring washer, item 2; and ram block washer, item 3.
2. Loosen setscrew item 73, enough to permit removal of shaft, item 63.
3. Remove nut, item 69, and rocker arm shoe, item 71. With these items removed, the rocker arm, item 74, can be lowered enough to permit removal of ram to front of shaper.

Lost Motion in Shaper Ram 1. Set screws on pulley, item 28, must be locked tight on flat of shaft, item 21.

1. screws on drive pulley, item 12 (page 34). These must also be tight.
2. Test rocker arm shoe, item 71, and bull gear shank bushing, item 58, for wear.
3. Check assembly screws on the following items:
 - item 90, bull gear
 - item 91, bull gear hub
 - item 93, stroke adjusting plate

Replacement of worn parts will reduce lost motion in ram to the minimum.

INSTRUCTIONS TO CUSTOMER FOR ADJUSTING SHAPER OIL PUMP

1. SET SHAPER FOR MAXIMUM STROKE AND SLOWEST SPEED.
2. POUR 1 QUART OF OIL (AS SUPPLIED) IN RESERVOIR.
3. LET SHAPER RUN FOR 30 TO 40 MINUTES. CHECK RAMWAYS FOR OIL FILM. THE SHAPER OIL PUMP HAS BEEN ADJUSTED AT THE FACTORY; HOWEVER, IF OIL IS EXCESSIVE OR INSUFFICIENT, REFER TO DIAGRAM.

OIL SPECIFICATION

MEDIUM WEIGHT MACHINE OIL.

SAYBOLT UNIVERSAL VISCOSITY APPROXIMATELY 200 SECONDS AT 100°F.

OIL MUST BE FREE OF DETERGENT OR OTHER HARMFUL ADDITIVES.

FORCE-FEED LUBRICATION TO RAM HAYS, BULL GEAR AND ROCKER ARM SHOE. OTHER PARTS ARE MANUALLY LUBRICATED. SAME OIL MAY BE USED. .

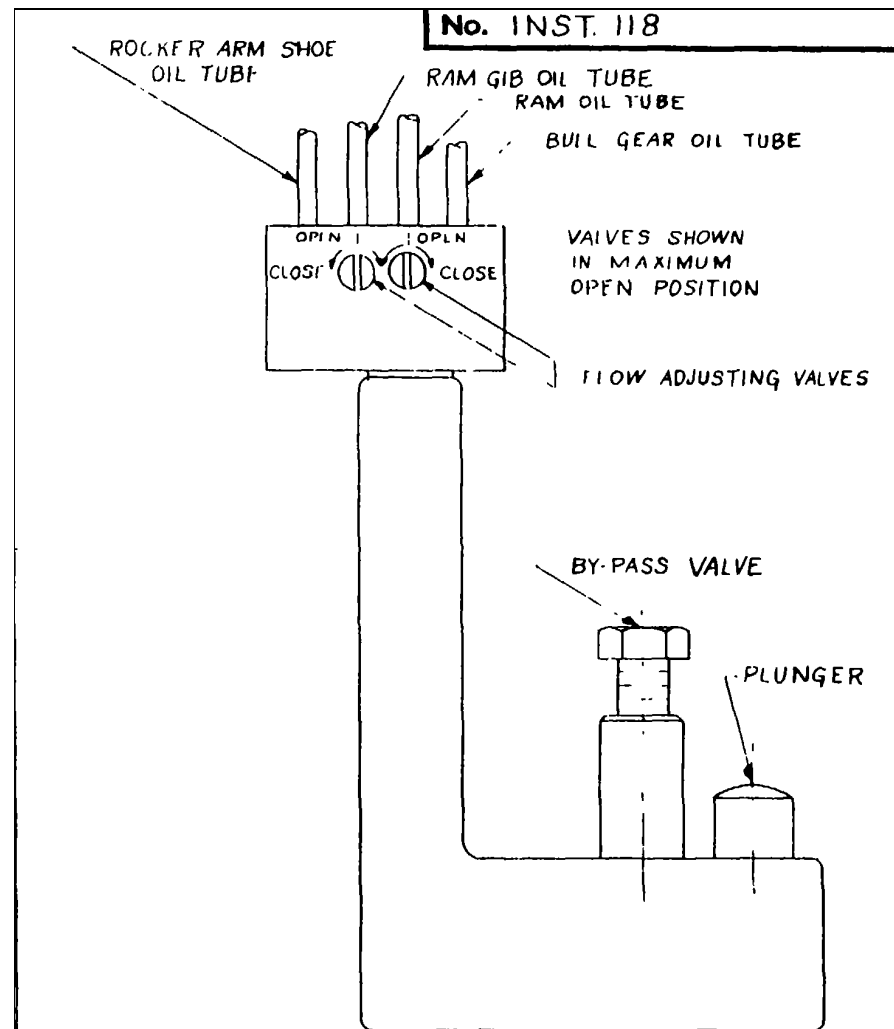

				UNIT			
				SHAPER OIL PUMP			
				SHEET NO.		NO. SHEETS	
				SCALE			
DRAWN BY		C'KD BY		TRACED BY		C'KD BY	
DATE	LET	WAS	DR	NOTICE			

IMPORTANT**PARTS AND ASSEMBLIES.**

The part numbers with prefixes "*" and "AS" identify assemblies and the parts included in these assemblies are indicated by the item numbers appearing in parenthesis after the part name. Such parts are not sent out individually, but as assemblies.

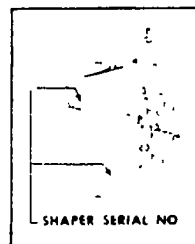
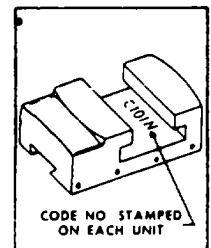

ORDERING INFORMATION. When ordering replacement parts, the serial number and code number are essential, but all of the following information is needed:

1. Serial No. & Model No.
2. Unit code number
3. Part number & name of part required
4. Quantity

PARTS LIST

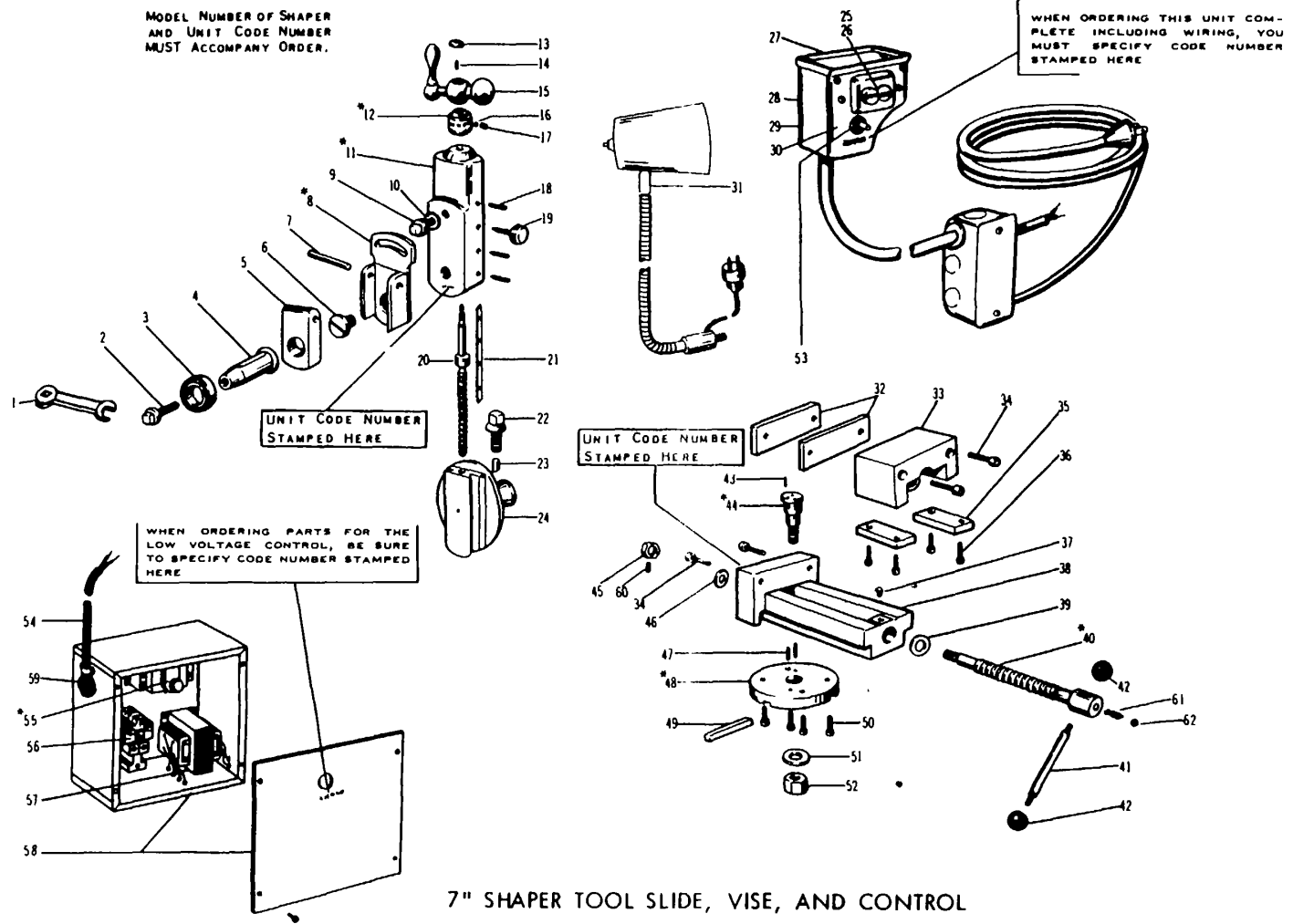

7" SHAPER TOOL SLIDE, VISE, AND CONTROL

PARTS LIST

7" Shaper Tool Slide, Vise and Control

ITEM	PART NO.	DESCRIPTION
1	CE2650NK	Wrench
2	PT233NK1	Tool Post Screw
3	PT5049S1	Tool Post Ring
4	PT250NK3	Tool Post
5	PT5048S1	Order Item No 8
6	PT5050S1	Swivel Screw
7	168 x 618	Taper Pin
8	*PA5047S2	Clapper Box (5-7)
9	PT5054S1	Lockscrew
10	161 x 17	Washer
11	*AS5012S1H	Tool Slide (18-19-21)
12	*AS5095S1	Graduated Collar (16-17)
13	PT295NR1	Crank Retaining Nut
14	160 x 17	Straight Pin
15	PA1264R1	Boll Crank
16	PT1076NR1	Binder Shoe
17	122 x 103	Setscrew
18	122 x 444	Setscrew
19	PT5052S1	Lockscrew
20	PT5043S1	Tool Head Screw
21	PT5051S1	Tool Slide Gib
22	PT5045S1	Clamp Bolt
23	PT5046S1	Clamp Shoe
24	PT5011S1	Tool Head Holder
25	PT4965S1	Push Button Switch 2 Pole
26	PT4995S1	Push Button Switch 3 Pole
27	PT5112S1	Tool Troy
28	PT5111S1	Switch Box
29	AS5111S1	Switch Box Assembly
30	PT5113S1	Switch Box Cover
31	PT5119S3	Work Table Light
32	PT4155S1	Vise Jaw
33	PT4151S1	Vise Jaw Frame
34	114 x 20	Capscrew
35	PT4154S1	Vise Jaw Gib
36	114 x 10	Capscrew
37	155 x 16	Ball Valve Oiler
38	PT4150S1	Vise Body
39	PT4158S1	Screw Washer
40	*AS4153S4	Vise Jaw Screw (39-45-46-60)
41	PT4161S1	Screw Handle
42	PT406NT1	Bakelite Boll
43	160 x 17	Pin
44	*AS5110S1	Hold Down Bolt (43)
45	138 x 29	Hex Jam Nut
46	PT4156S1	Thrust Washer
47	160 x 52	Straight Pin
48	*AS4152S1	Graduated Vise Base (47)
49	PT4160S1	Key
50	114 x 8	Capscrew
51	161 x 30	Finished Washer
52	136 x 31	Hex Full Nut
53	PT4063DP1	Toggle Switch
54	250 x 10	6 Wire Cable
55	AS4086DP1	Thermal Overload Relay And Base
56		Power Relay (Specify Power Characteristics)
57	PT4085DP1	Transformer
58	PT4083S1	Control Box and Cover
59	SE7300	Angle Connector
60	160 x 25	Pin
61	PT 36 39 LH1	Spring
62	PT1080NK1	Shoe

PARTS LIST

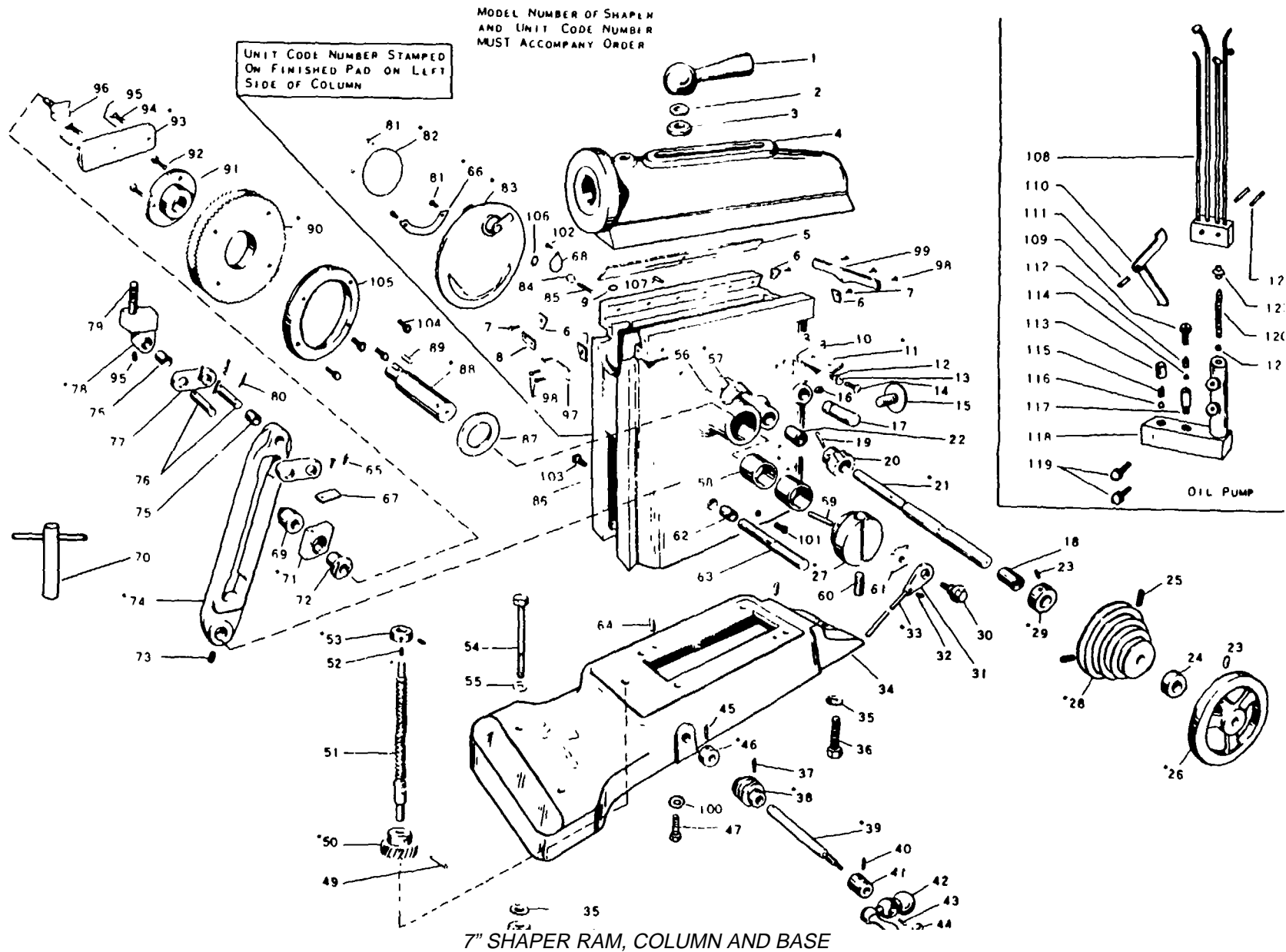

PARTS LIST

7" Shaper Ram, Column and Base

ITEM NO.	PART NO.	DESCRIPTION
1	PT5019S1	Ram Block Handle
2	PT5109S1	Spring Washer
3	PT5018S1	Ram Block Washer
4	PT5002S2	Ram
5	PT5007S3	Ram Gab
6	PT4892S1	Chip Scraper
7	132 x 1101	Phillips Screw-
8	PT4957S1	Left Front Oil Drain
9	PT4898-1	Plug
10	PT387NK1	Rubber Bumper
11	*AS5099S1	Guard Bracket (12-13-14)
12	160 x 20	Straight Pin
13	180 x 300	Lock Washer
14	101 x 608	Round Head Screw
15	PT4991S1	Corn
16	121 x 104	Setscrew
17	PT5092S1	Pivot Stud
18	PT5028S2	Drive Shaft Bushing (Long)
19	168 x 107	Taper Pin
20	PT5034S1	Pinion Gear
21	*PA5009S2	Drive Shaft (19-20)
22	PT5029S1	Drive Shaft Bushing (Short)
23	120 x 108	Setscrew
24	PT4963S1	Collar
25	120 x 8	Setscrew
26	*AS5005S1	Handwheel (23)
27	*AS5078S2	able Feed Eccentric (59) I
28	*AS5010S1	Pulley (25)
29	*AS5040S2	Drive Pulley Collar (23)
30	PT5077S2	Eccentric Lock Screw
31	PT5075S1	Order Item No 33
32	160 x 19	Pin
33	*AS5079S1	Feed Rod (31-32)
34	PT5000S4	Base
35	182 x 304	Lock Washer
36	112 x 424	Hex Bolt
37	168 x 107	Taper Pin
38	*AS5100S1	Worm (37)
39	*AS5056S1	Elevating Crank Shaft (40-41-42-43-44)
40	160 x 27	Straight Pin
41	PT5067S1	Crankshaft Collar
42	PA1264R1	C F Bill Crank
43	160 x 17	Pin
44	PT295NR1	Crank Rejoining Nut
45	168 x 107	Taper Pin
46	*AS5071S1	Collar (46)
47	112 x 214	Capscrew
48	138 x 31	Hex Nut
49	168 x 411	Toper Pin
50	*AS5101S1	Worm Gear (50)
51	PT5057S1	Elevating Screw
52	120 x 5	Setscrew
53	*AS5066S1	Elevating Screw Collar (52)
54	112 x 460	Hex. Bolt
55	161 x 26	Washer
56	130 x 103	Metallic Drive Screw
57	*AS5102S1	Stroke Adj Plate (56)
58	PT501552	Bull Gear Shank Bushing
59	168 x 618	Taper Pin
60	PT5041S1	Eccentric Lock Screw Nut
61	PT5096S1	Table Feed Pointer
62	PT5024S1	Rocker Arm Shaft Bushing
63	PT5037S1	Rocker Arm Shaft (Long)
64	153 x 2	Locating Pins

ITEM NO.	PART NO.	DESCRIPTION
65	101 x 6	Mach. Screw
66	AS4890S1	Oil Spec. Chart (81)
67	PT4893S1	Rocker Arm Shoe Oil Tray
68	PT2531RT1	Oil Hole Cover
69	PT5036S1	Stroke Adj. Stud Nut
70	CE2750	Tee Wrench
71	*AS5042S1	Rocker Arm Shoe (65-67)
72	PT5031S1	Shoe Lock Bushing
73	118 x 108	Setscrew
74	*AS500S1	Rocker Arm (73)
75	PT5030S1	Ram Block Bushing
76	PT5023S1	Rocker Arm Shaft (Short)
77	PT5022S1	Rocker Arm Link
78	*AS5021S2	Ram Block (75-79-95)
79	PT5020S2	Order Item No 78
80	170 x 310	Cotter Pin
81	130 x 103	Drive Screw
82	*AS3303	Insignia Plate (81)
83	PA5004S2	Cover Plate (81-82-66)
84	138 X 18	Hex Nut
85	PT2980-1	Setscrew
86	PT5001S7	Column
87	PT4895S1	Bull Gear Spacer
88	*AS5013S1	Bull Gear Shank (89)
89	160 x 74	Pin
90	PT5006S5	Bull Gear
91	PT5008S2	Pull Gear Hub
92	114 x 12	Capscrew
93	*AS5014S1	Stroke Adj Plate (94-95-96)
94	103 x 614	Machine Screw
95	160 x 19	Straight Pin
96	PT5038S1	Stroke Adj. Stud
97	PT4956S1	Right Front Oil Drain
98	114 x 1204	Screw
99	PT4958S1	Rear Oil Drain
100	161 x 16	Washer
101	152 x 62	Pipe Plug
102	101 x 306	Screw
103	PT1511-1	Rear Oil Drain
104	114 x 12	Capscrew
105	PT4961S1	Oil Pump Cam
106	PT4946-1	Plug
107	PT4897S1	Oil Tube Connector
108	AS4955S2	Junction Box Assembly
109	PT4952S1	Relief Valve Stem
110	PT4960S2	Oil Pump Lever
111	160 x 87	Pin
112	162 x 55	Spring
113	PT3090H1	Oil Pump Plunger
114	172 x 12	Steel Ball
115	162 x 49	Spring
116	172 x 14	Steel Ball
117	PT4951S1	Relief Valve Body
118	PT4950S1	Oil Pump
119	103 x 208	Screw
120	162 x 56	Spring
121	PT4894S1	Flow Adj Valve
122	172 x 12	Steel Ball
123	PT4953S1	Flanged Connector

PARTS LIST

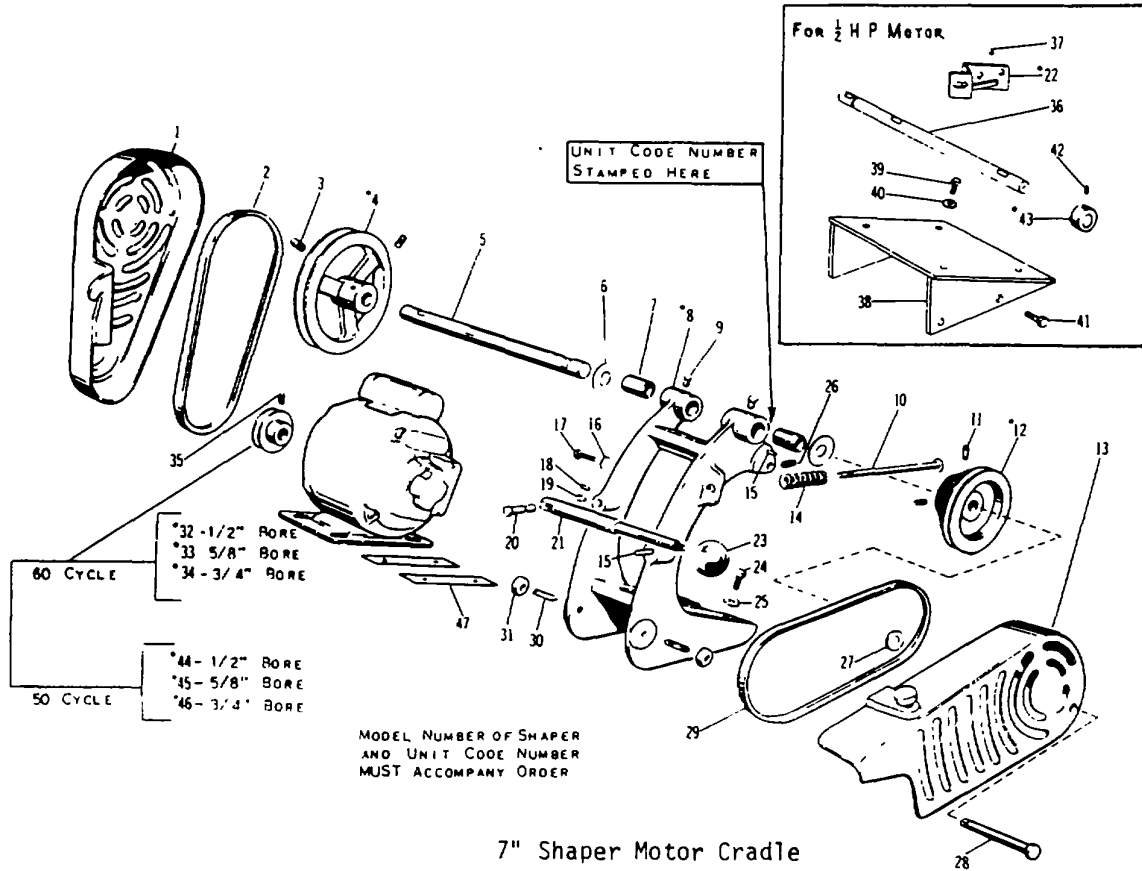

7" Shaper Motor Cradle

ITEM NO.	PART NO.	DESCRIPTION
1	PT5087S1	Motor Pulley Guard
2	CE4L280	V Belt
3	120 x 106	Setscrew
4	*AS5088S1	Countershaft Pulley (3)
5	PT5089S2	Countershaft, 1/3 H.P.
6	PT5108S1	Countershaft Washer
7	PT4997S1	Bushing
8	*AS5086S3	Motor Cradle (7 - 9 - 15 - 18)
9	155 x 20	Gits Oiler
10	PT4990S1	Cradle Tension Bolt
11	120 x 108	Setscrew
12	*AS5010S1	Drive Pulley (11)
13	PA5097S2	Drive Pulley Guard
14	PT4988S1	Cradle Tension Spring
15	160 x 90	Straight Pin
16	161 x 12	Washer
17	112 x 116	Capscrew
18	PT1803	Straight Pin
19	120 x 5	Setscrew
20	PT4987S1	Pin
21	PT4989S2	Cradle Adjusting Lever
22	*AS4992S2	Bracket (37)
23	PT406K&FHL	Bakelite Ball
24	112 x 112	Capscrew
25	161 x 12	Washer

ITEM NO.	PART NO.	DESCRIPTION
26	121 x 104	Setscrew
27	PT4985S1	Washer
28	PT5098S3	Guard Stud
29	CE4L290	V Belt
30	PT704DP1	Setscrew
31	138 x 27	Hex. Nut
	Shaper Electric Motor
32	*AS5400S1	Motor Pulley (35)
33	*AS5401S1	Motor Pulley (35)
34	*AS5402S1	Motor Pulley (35)
35	120 x 105	Setscrew
36	PT4983S2	Countershaft, 1/2 H P
37	160 x 236	Pin
38	PA4993S1	Motor Base Adapter, 1/2 H P
39	112 x 108	Capscrew
40	161 x 12	Washer
41	112 x 110	Capscrew
42	120 x 5	Screw
43	*AS4982S1	Collar (42)
44	*AS4979S1	Motor Pulley (35)
45	*AS4980S1	Motor Pulley (35)
46	*AS4981S1	Motor Pulley (15)
47	PT4999S1	Motor Shim

PARTS LIST

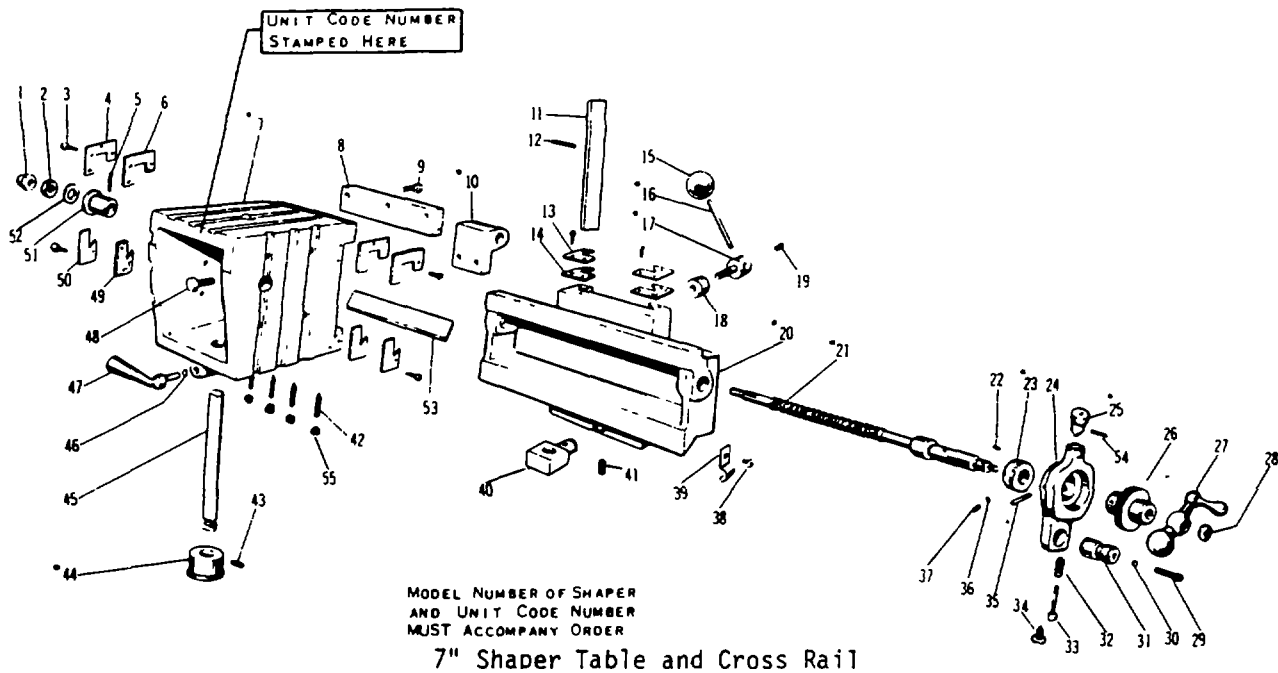

7" Shaper Table and Cross Rail

ITEM NO.	PART NO.	DESCRIPTION
1	PT4066DP1	Acorn Nut
2	139 x 27	Hex. Jam Nut
3	132 x 1103	Phillips Screw
4	PT4966S1	Sq. C. R Felt Retainer
5	160 x 16	Straight Pin
6	PT4967S1	Sq. C R. Felt Wiper
7	*AS5085S1	Table (3 - 4 - 6 - 8 - 9 42 - 49 - 50 - 53 - 55)
8	PT5070S1	Top Guide Gib
9	111 x 14	Capscrew
10	*AS5058S2	C F Screw Nut (48)
11	PT5068S2	Cross Rail Gib
12	121 x 1012	Setscrew
13	PT4968S1	Column Felt Retainer
14	PT4969S1	Column Felt Wiper
15	PT406NT1	Bakelite Ball
16	*AS5064S1	Cross Rail Lock Handle(15)
17	*AS5072S1	Cross Rail Lock Bolt (19)
18	PT5065S1	Cross Rail Lock Wedge
19	120 x 903	Setscrew
20	*AS5084S3	Cross Rail (11 - 12 - 13 -14)
21	*AS5055S3	Cross Feed Screw (22 - 23 - 24 -25 - 6 27 - 28 - 32 - 33 - 34 - 35 - 36 - 37 - 54)
22	160 x 17	Straight Pin
23	*AS5063S1	Cross Feed Grad Collar (36 - 37)
24	PT5082S2	Feed Pawl Lever
25	*AS5083S1	Pawl Lever Knob (32-33-54)

ITEM NO.	PART NO.	DESCRIPTION
26	PT5076S1	Rocker Arm Ratchet Wheel
27	PA1264R1	C F Ball Crank
28	PT295NR1	Crank Retaining Nut
29	118 x 16	Setscrew
30	PT1082FH1	Brass Shoe
31	PT5074S1	Rocker Arm Pivot
32	PT5105S1	Feed Pawl Spring
33	PT5080S1	Feed Pawl
34	PT4998S1	Rocker Arm Pivot Screw
35	PT1809	Straight Pin
36	PT1076NR1	Shoe
37	122 x 102	Setscrew
38	101 x 304	Machine Screw
39	PT3096H1	Oil Tube Clamp
40	PT5069S2	Elevating Screw Nut
41	120 x 6	Setscrew
42	121 x 1016	Setscrew
43	PT4972S1	Setscrew
44	*AS5060S3	Table Support Bracket (43)
45	PT5059S2	Table Support Shank
46	PT1084H1	Brass Shoe
47	PT5061S1	Binding Lever
48	112 x 116	Capscrew
49	PT4971S1	C K Felt Wiper
50	PT4970S1	C R Felt Retainer
51	PT5073S2	Bushing C F. Thrust
52	PT5026S2	Spring Washer
53	PT5062S1	Table Gib
54	160 x 260	Straight Pin
55	138 x 18	Nut

SPECIAL INFORMATION

CARE OF MACHINE TOOLS THAT ARE NOT IN USE

When a machine is taken out of service, such as in a school where they would not be used during the summer months or at some other vacation or off period, it should be properly taken care of as follows:

1. Thoroughly clean the machine, being sure that all surfaces are cleaned. It is as important to clean the painted surfaces as well as the machined surfaces. The machine should be cleaned with some type of solvent if the machine has accumulated hard to remove deposits. If all deposits are not removed and a protective coating is applied, it will make the machine doubly hard to clean when the machine is put back into service. A neutralizing agent should be used where finger printing is common or where the climate is very damp.
2. After the machine has been thoroughly cleaned all of the machined surfaces should be covered with either a good grade of medium weight MACHINE OIL (NOT AUTO ENGINE OIL) or if the machine is going to be out of service for a long period of time a light weight grease (commercial petroleum jelly that has been thinned with naphtha or mineral spirits is very good) should be used. When covering the machine surfaces care should be taken so that the machined surfaces are completely covered. Also you should try and keep the oil and grease off the painted surfaces.
3. If the machine has belts of any type, they should be loosened, so that they will not stretch while the machine is not in use.
4. All power to the machine should be disconnected. Some machines could be very easily damaged if run after being out of service for a long period of time.
5. The machine should be covered with a cover that will keep dust and dirt from accumulating on it. Also the cover should be liquid repellent to keep any liquid from coming into contact with the working parts of the machine.

By Order of the Secretary of the Army.

Official:

E. C. MEYER
General, United States Army
Chief of Staff

ROBERT M. JOYCE
Brigadier General, United States Army
The Adjutant General

Distribution:

To be distributed in accordance with Special List.

*US. GOVERNMENT PRINTING OFFICE: 1984-461-202/11533

RECOMMENDED CHANGES TO EQUIPMENT TECHNICAL PUBLICATIONS



THEN... JOT DOWN THE DOPE ABOUT IT ON THIS FORM, CAREFULLY TEAR IT OUT, FOLD IT AND DROP IT IN THE MAIL!

SOMETHING WRONG WITH THIS PUBLICATION?

FROM: (PRINT YOUR UNIT'S COMPLETE ADDRESS)

DATE SENT

PUBLICATION NUMBER

PUBLICATION DATE

PUBLICATION TITLE

BE EXACT... PIN-POINT WHERE IT IS

PAGE NO.

PARA-GRAPH

FIGURE NO.

TABLE NO.

IN THIS SPACE TELL WHAT IS WRONG AND WHAT SHOULD BE DONE ABOUT IT:

TEAR ALONG PERFORATED LINE

PRINTED NAME, GRADE OR TITLE, AND TELEPHONE NUMBER

SIGN HERE:

DA FORM 2028-2
1 JUL 79

PREVIOUS EDITIONS ARE OBSOLETE.

P.S.—IF YOUR OUTFIT WANTS TO KNOW ABOUT YOUR RECOMMENDATION MAKE A CARBON COPY OF THIS AND GIVE IT TO YOUR HEADQUARTERS.

