

SHOP NOTES

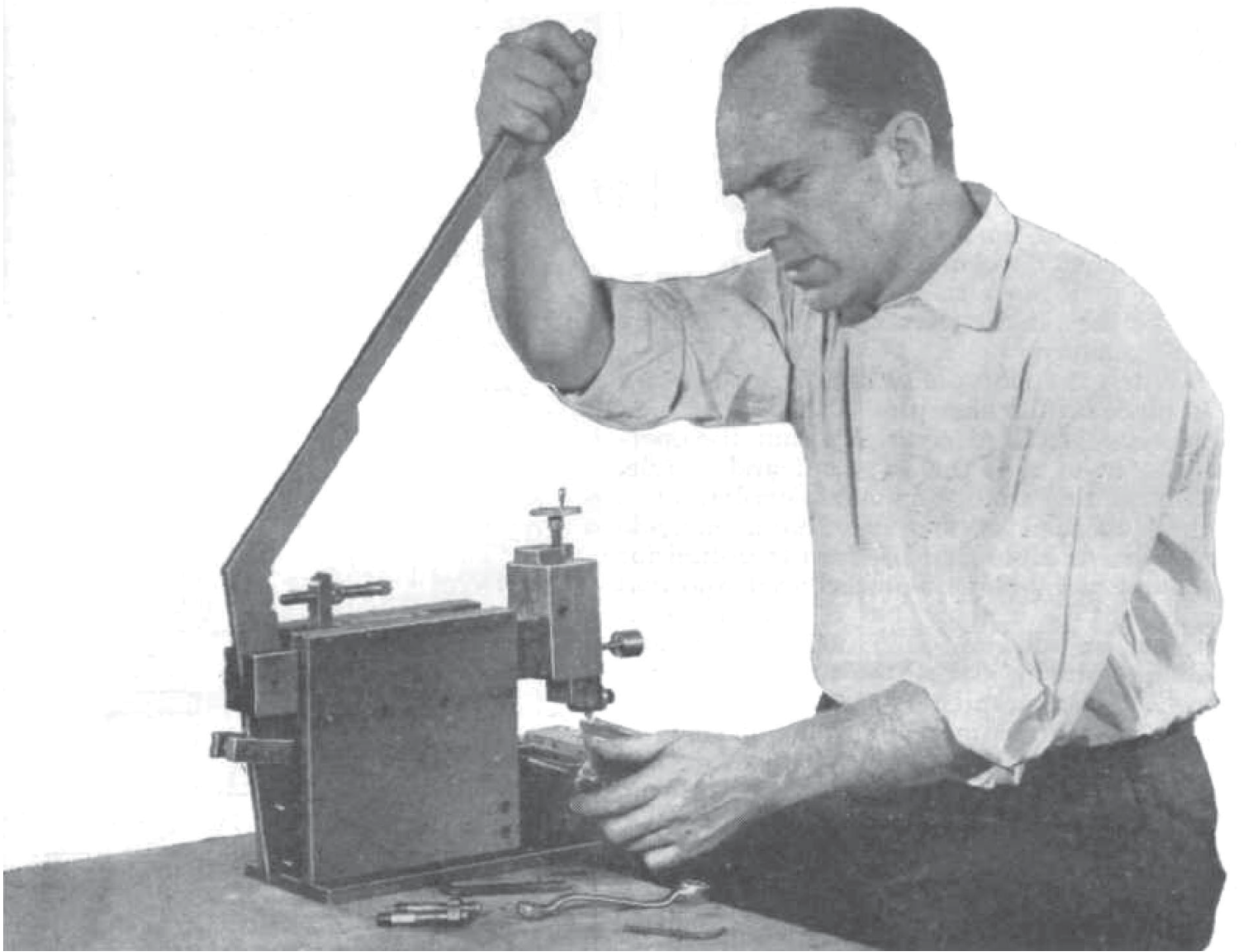

METAL SHAPER FOR YOUR SHOP

By S. S. Miner

A METAL SHAPER is indispensable for certain machining operations where flat surfaces must be produced within very close limits, such as machining flats on castings, cutting keyways, rabbets and grooves and reducing the thickness of stock to a given dimension. This one has a 3-in. stroke, is manually operated and has been especially designed to reduce machine operations in the construction to the minimum. Cold-rolled-steel flats and squares are utilized for nearly all operating parts and the frame and base. These parts you can purchase cut to size with "store" edges at a very reasonable cost per piece. Joining edges and flat surfaces can be finished by hand to remove saw or flame marks and square the surfaces for fitting.

One thing to keep in mind before beginning the construction: Hole layouts are given on the parts dimensioned on the following pages, but the hole sizes have been omitted. The reason is that you have a choice of two methods of assembly. On the original

machine the parts were joined with socket-head screws, the screwheads countersunk flush. The alternate method is to drill the body and tap holes only, omitting the counterbores. This latter method effects a considerable saving in construction time and does not impair the efficiency of the machine in any way. Use 1/4-in. socket-head screws or hex-head screws except where other thread sizes are given. The length of the screw is determined by the thickness of the stock and also the location of the screw.

Begin construction with the base plate, the two side plates and the feed block: Only the front edge of the base plate, the bottom edges of the side plates and the front end of the bed block are finished. This must be done with care to assure flat true surfaces. Next, lay out and drill the body-hole pattern in the base plate and side plates and then use these three members as jigs when drilling the tap holes in the ram guides and the bottom edges of the side plates. Note the location of the dowel-pin holes in the various parts. Holes for

the dowel pins are drilled and reamed so that the pins are a medium-tight drive fit. When body holes and holes for the dowel pins are drilled the parts must be clamped together securely. Then drill and ream the pinholes first. Drive the pins in part way before drilling the tap holes.

When the side plates and bed block are in place on the base plate the next parts to make and fit in place are the ram, the operating lever and the crossrail and saddle.

The saddle cannot be made complete until the cross-feed screw bracket has been made and fitted. Note that the ram is slotted for the operating lever, counterbored, and that a round, $63/64$ in. long and $1\ 1/2$ in. in dia., is turned on one end. This must be done in a metal lathe to assure the necessary accuracy.

The ram must be a smooth sliding fit in the guides. Some light filing and smoothing with abrasive will be necessary to achieve the required fit. Note in the ram detail that section A-A gives the oilhole plan. These holes must be drilled before final assembly.

Make the operating lever and link next. Note in the lever detail that it consists of three parts, two of which are brazed to the third at a 45-deg. angle. Section A-A shows how the meeting edges are beveled before brazing. Form a radius on the body of the lever to provide a landing for the stop screw. Top end of the lever can be fitted with a plastic knob, or a handhold is easily shaped by grinding and filing.

The link, which is a part of the lever assembly, consists of two steel squares pinned and screwed to a spacer. In this case the heads of the socket-head screws must be countersunk flush for clearance. Note also that the link pivot pin is grooved to provide a seat for the end of the retaining screw. The link is provided with bronze bushings.

The head assembly consists of the head block and the toolhead slide, the latter built up from steel squares and flats as detailed, the parts of the slide being assembled with screws and pins. The head block is a swiveling clamp which fits over the round turned on the end of the ram. When the assembly is complete with the down-feed bracket and tool block the entire assembly can be swiveled on the ram to locate the cutting tool at any desired angle with the work. Note that the toolhead is fitted with a spring-loaded drag, which has the effect of taking slack out of the down-feed screw and also to prevent chattering on heavy cuts.

Beginning construction of the assembly with the head block, bore the block to $1\ 1/2$ - in. dia. before slotting. The slot is cut with two hacksaw blades placed side by side in the saw frame. Take time to assure a straight cut and finish with a file. Then counterbore and tap for the clamping screw, the counterbore on one side of the slot, the tap hole on the other. Next, turn and thread the down-feed and cross-feed screws in the lathe. Now, note that the end of the toolhead is drilled to take the end of the down-feed screw and that the lower end of the down-feed screw is grooved

to take the shouldered end of a retaining screw. Drill this hole to a depth of about $9/16$ in. and test-fit the end of the down-feed screw before final assembly. There will be a slight amount of end play in the screw and it is necessary to make sure that it will clear when run up or down. If it should bind on the bottom of the hole you will have difficulty adjusting the cutting tool.

With the toolhead and slide completed and the parts fitted in the final assembly, disassemble and fit the down-feed screw bracket. Note that it is both pinned and screwed in place and care must be taken to assure a true fit on the upper end of the head block.

The head assembly is completed with the addition of the tool-holding block. Note especially the elongated hole in the upper end of this block. The elongation permits the block to swing outward on the back stroke of the ram. The counterweight drops it into cutting position again as it clears the edge of the stock being cut. This elongation of the hole must be worked with a file and several tests made as the job progresses to assure just the right amount of clearance. The cutting tool is held in place by means of the washer detailed and a socket-head screw turned into a tapped hole near the lower end of the block.

The cross-feed screw bracket is made by notching and bending a length of square stock. Note in the details that one leg of the bracket (after bending and brazing) is drilled $7/16$ in., the other $3/8$ in. Note also that the screw is shouldered to three diameters to permit it to be slipped into place after the bracket is bent to form. However, before assembling the screw in the bracket it is necessary to make the lug through which the screw is threaded at assembly. This lug has a bottom hole which fits over a fillister-head screw turned into a hole tapped into the bed block. When making these parts a careful layout is essential to assure correct location of the holes so that the screw runs freely throughout the length of the threaded section. This is important as it should be remembered the feed of the work is by hand. If the screw is correctly aligned when assembled, but still has considerable drag, disassemble, and remount the screw in the lathe. Take a light cut over the threads to reduce the contact to about 60 to 70 percent. Usually this will ease the fit sufficiently so that the screw will run freely. Three handwheels are required, one for the down-feed screw, the other two for the cross-feed screw.

The stop-screw bracket is not detailed as it is necessary to fit it to the machine in order to assure that the stop is correctly positioned to assure contact with the landing on the operating lever. Take measurements from the assembly and make the bracket accordingly from $1/2$ -in. stock.

The saddle and clamp plate are the last parts to be made and fitted. The clamp plate is carried on four studs made as detailed and screwed into holes tapped in the saddle. Clamping is done by tightening nuts run onto the threaded ends of the studs. After assembly, test all parts.

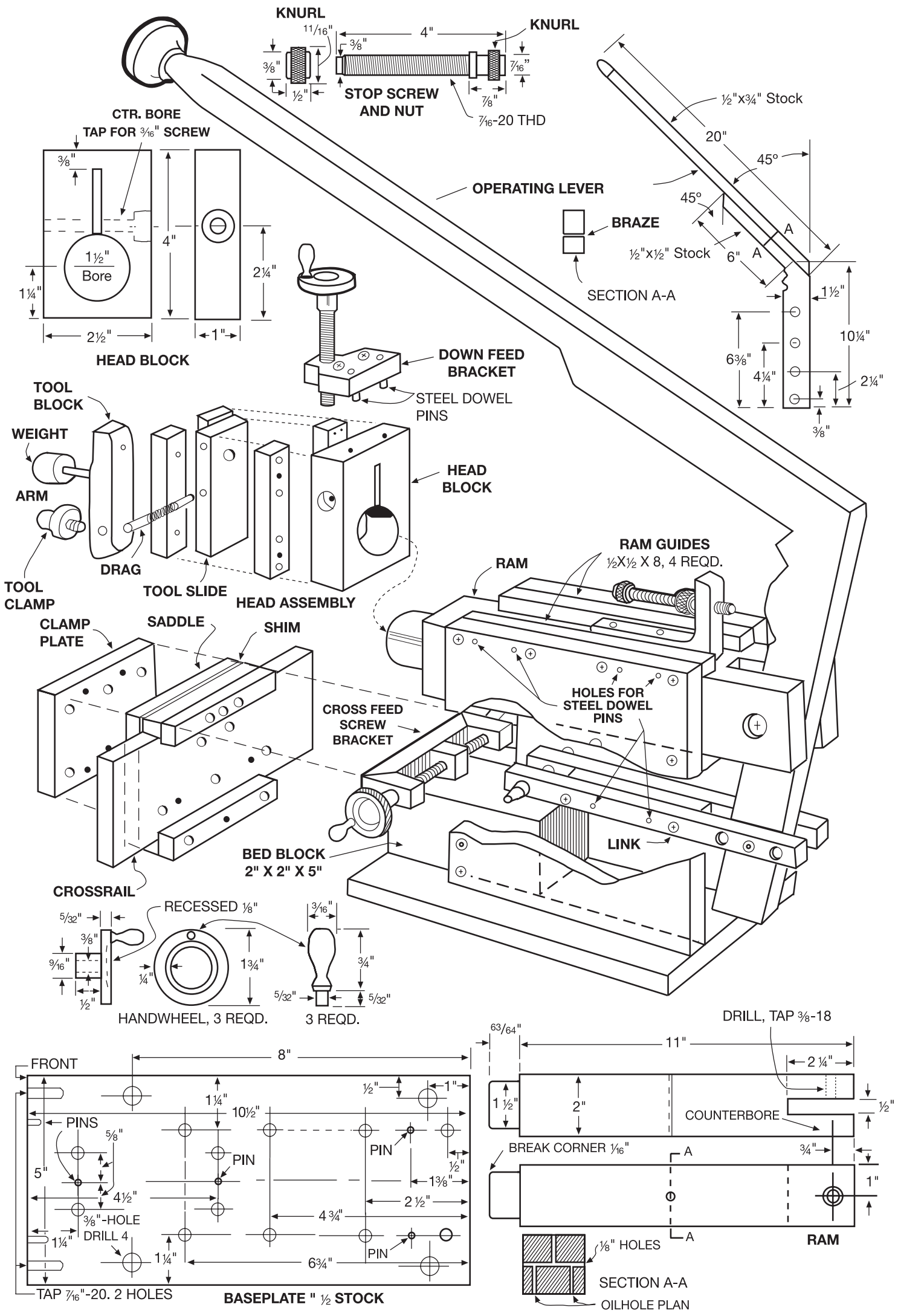

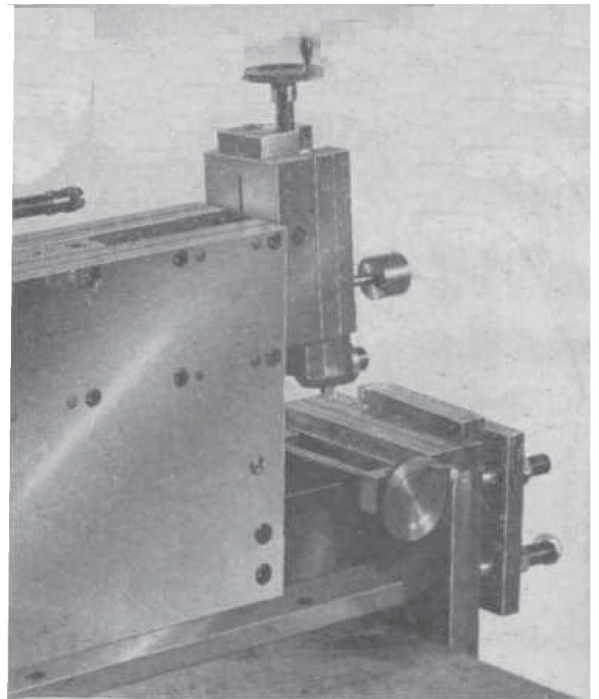
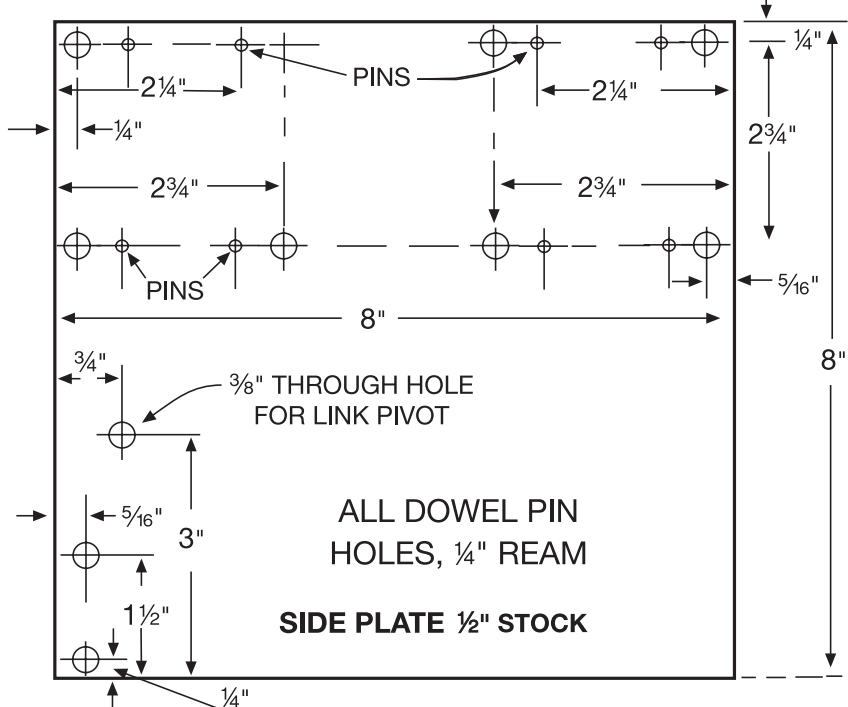
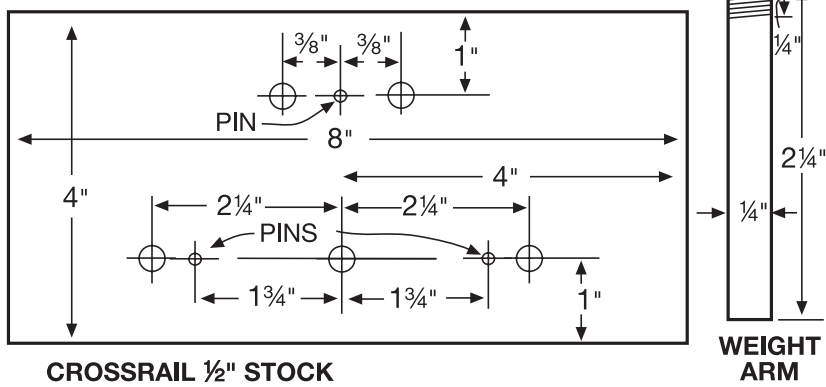
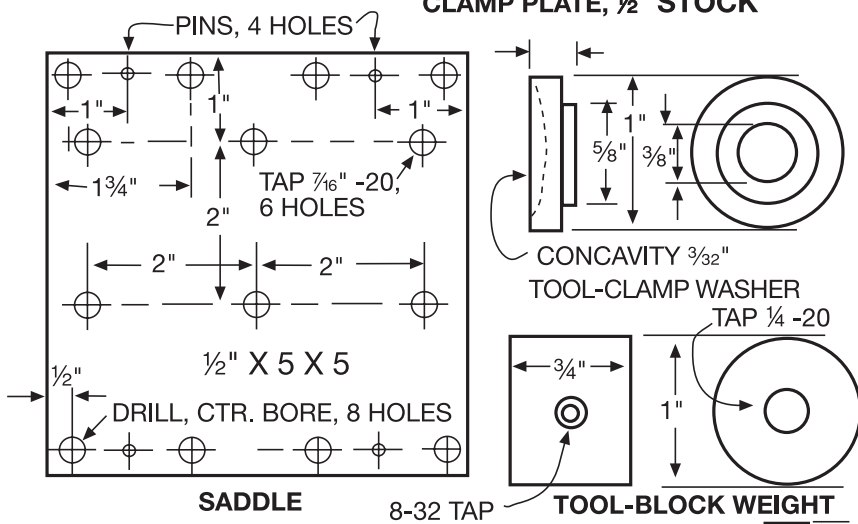
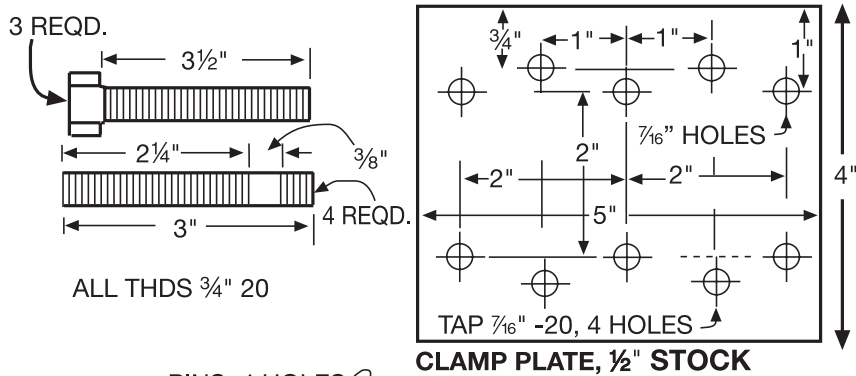
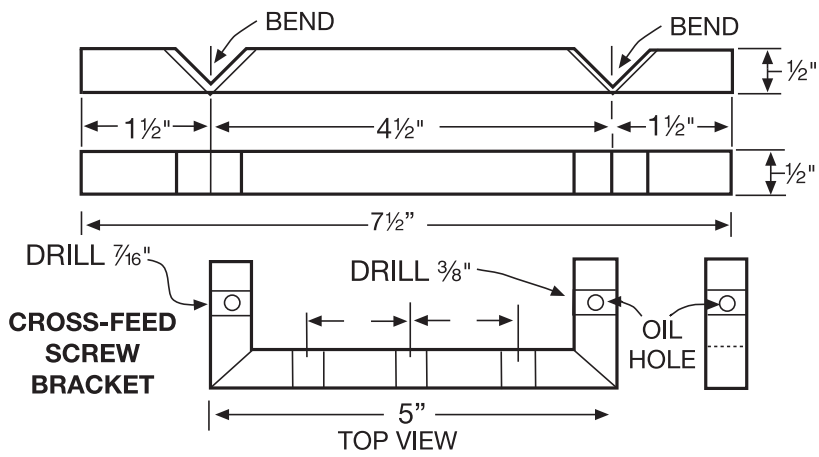
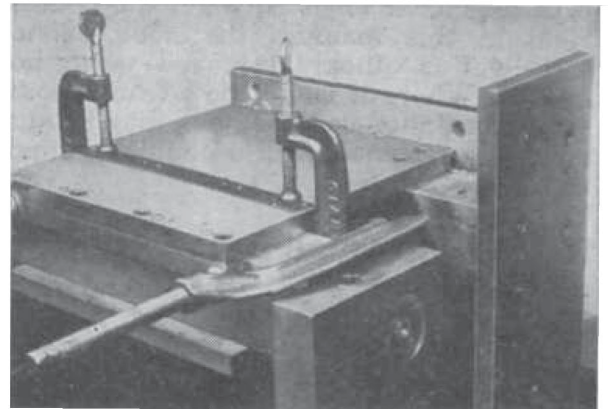
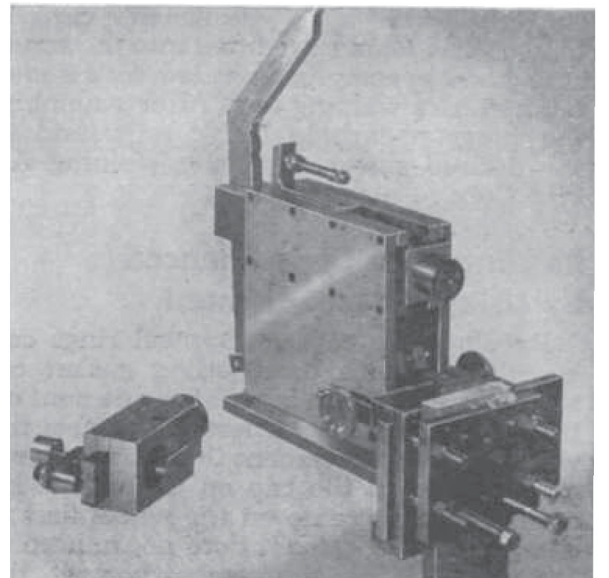

Photo shows head assembly and crossrail, saddle and clamp plate in position with work clamped in place



Method of clamping parts in position for fitting and drilling screw holes.



Head assembly removed showing round turned on end of square ram

