



*Now*

---

---

---

*Jacobs*

THE JACOBS MANUFACTURING COMPANY, WEST HARTFORD 10, CONNECTICUT, U.S.A.

BULLETIN  
57-LC

## UNEQUALLED GRIPPING POWER

Two to four times the gripping power of present split steel collet equipment. You can now use maximum speeds and feeds of your modern tool room lathes.

## LESS OVERHANG

The compact design permits chucking close to the spindle nose. It allows a saving of 1" to 1½" of overhang compared to the steel collet chucks now on the market.

## CAPACITY

This chuck with its set of eleven collets will chuck ANY BAR between 1/16" and 1 3/8" — no longer necessary to stock collets in 1/16", 1/32", 1/64", millimeter, and decimal sizes. Also permits use of full spindle hole diameter — thus increasing the bar capacity of your lathe.

## ULTRA ACCURACY

This precision built chuck and its collets deliver accuracy never before realized on lathe collet equipment. The most accurate collet chuck in the world today.

## SAFETY

When in closed position, the chuck is positively locked to the spindle. It cannot open when lathe is quickly stopped or reversed.

## DURABILITY

The Handwheel is solid aluminum and the forged alloy steel body is hardened and ground. All other parts of the chuck are of alloy steel, hardened and ground throughout.

## ECONOMY

You buy a chuck that will perform a COMPLETE job of chucking — you save both on original investment and maintenance.

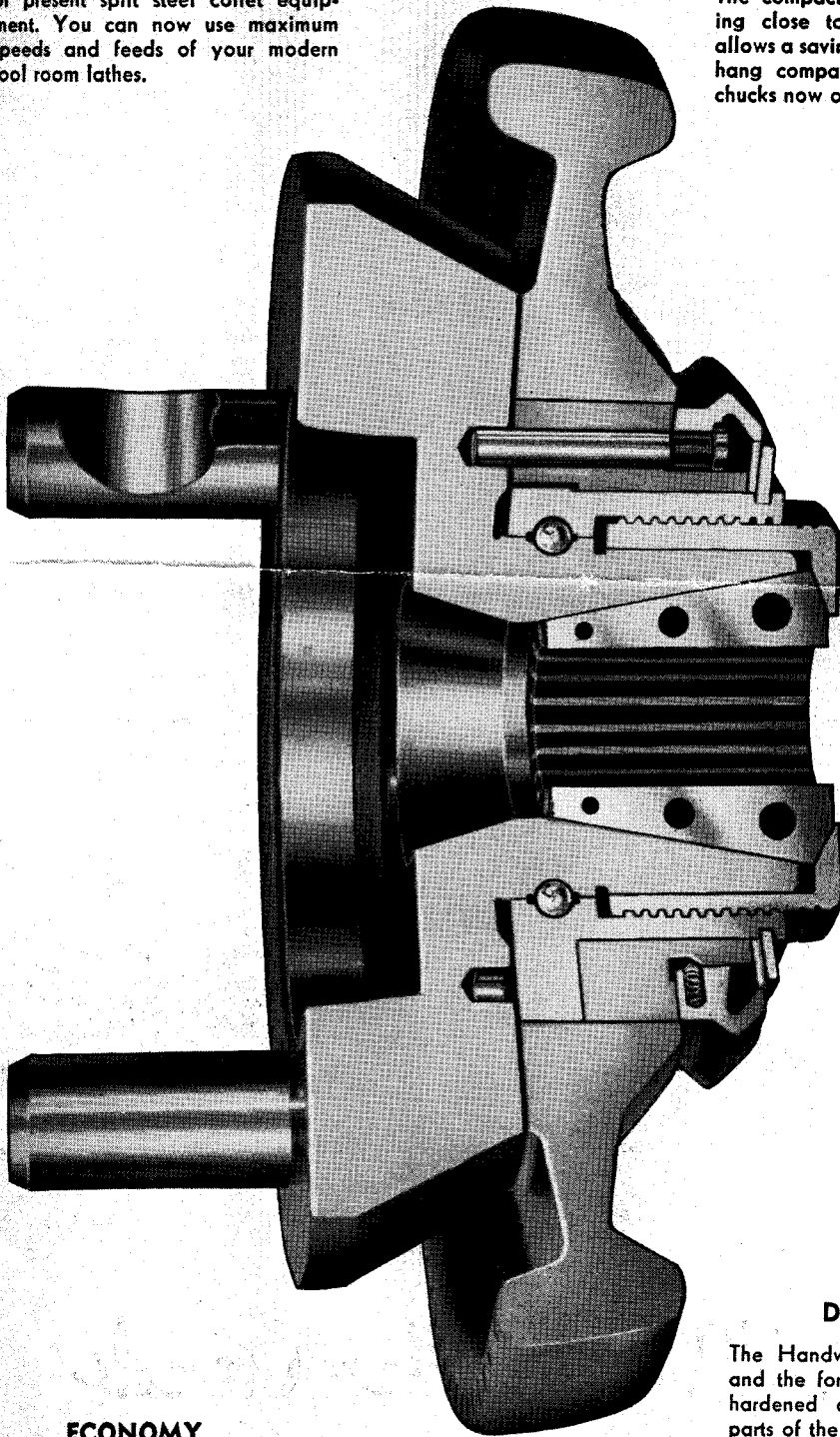

# Jacobs revolutionary Rubber-Flex<sup>®</sup> collet has tightest, most accurate grip ever devised!

1 Multiple parallel jaws with long bearing surfaces distribute the grip equally throughout the collet and do not allow concentration at the nose, as do steel collets, when they are closed down below nominal size.

2 The extra long bearing surface of all collet jaws (50%-75% longer than steel collets) are always parallel to the work and in full contact throughout the  $\frac{1}{8}$ " range of the collet.

3 All external and internal collet surfaces are precision ground.

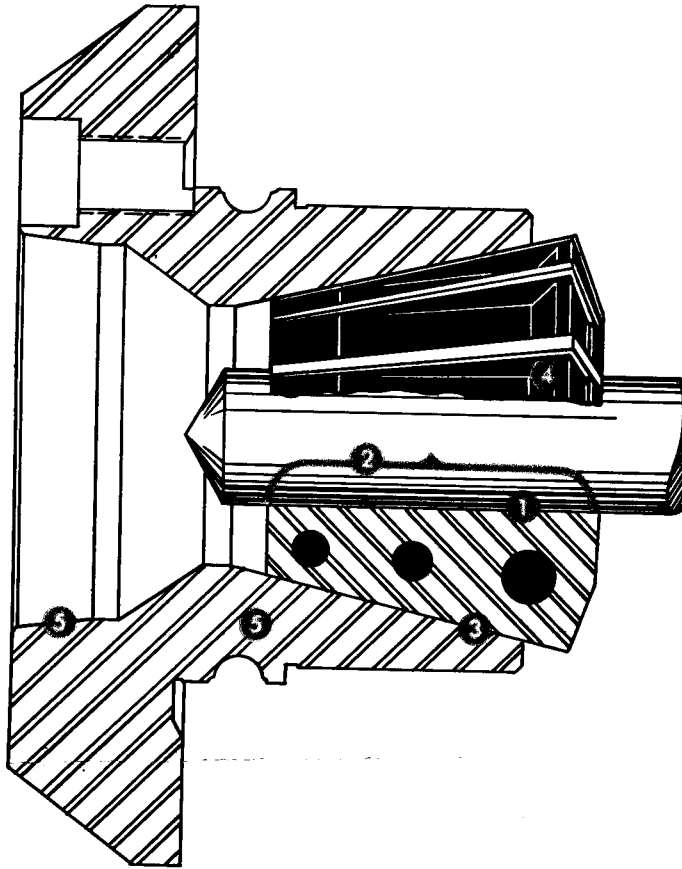

4 The Hycar synthetic rubber manufactured and moulded by Jacobs is not affected by heat, coolants, or cutting compounds. It will not lose its flexibility nor separate from the jaws during many years of hard use.

5 Entire chuck body, including back mounting surface and collet seating cone, is machined from a single alloy steel forging, hardened and precision ground throughout.

1 Unlike steel collets, no concession is necessary for spring temper and the alloy steel collet jaws are held to maximum hardness for long wear under rugged conditions.

2 The rubber in the collet is moulded to provide a complete seal over the work and thus prevent the entry of chips, dirt, and coolants into the chuck.

3 The rubber is permanently bonded and mechanically locked to the jaws.

4 Even when tightened for your heaviest cuts, these collets will not score the outside of the bar being chucked.

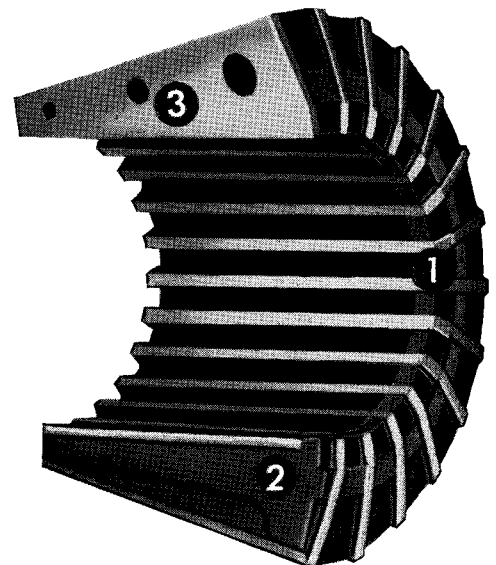

# One collet has the gripping range of nine or more

cover a  $\frac{1}{8}$ "  
e, you need —

Steel Collets  
4ths

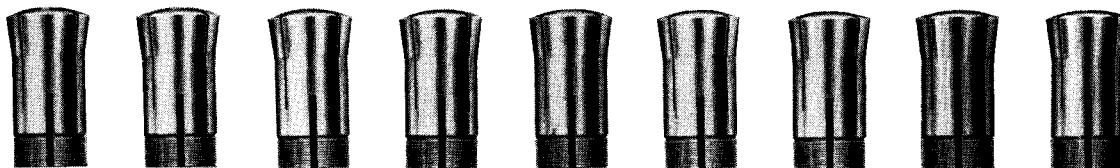

Steel Collets  
2nds

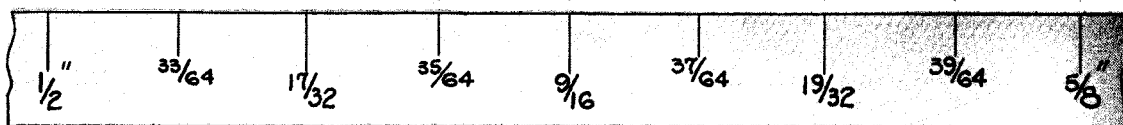
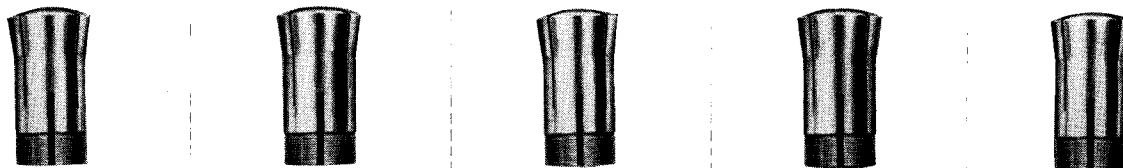

Jacobs Rubber-Flex Collet



Consider the number of conventional steel collets required to equal the  $\frac{1}{8}$ " range and performance of a single Jacobs Rubber-Flex Collet. Even a set of eighty-eight (by  $\frac{1}{64}$ ths) will not equal the capacity of our complete set of eleven. This Jacobs Collet eliminates the expensive stocking and maintenance of collets in  $\frac{1}{16}$ ",  $\frac{1}{32}$ ",  $\frac{1}{64}$ ", millimeter, and decimal sizes. It also gives you those plus values in accuracy, gripping power, and durability.

## THE JACOBS COLLET DOES THIS

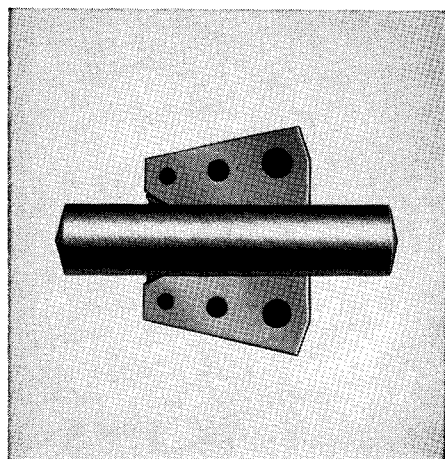

In closing down the collet throughout the entire  $\frac{1}{8}$ " range, perfect parallelism is maintained between the extra long collet bearing surfaces and the work — accuracy and gripping pressure are constant throughout the entire range.

## AND NOT THIS

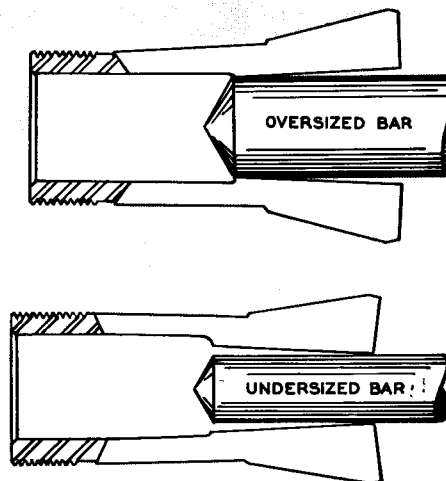

The split steel type collet can only provide maximum grip and accuracy at its actual bored or nominal capacity. In chucking bars even a few thousandths over or under this dimension, parallelism is lost. Gripping power and accuracy are therefore greatly reduced.

## Another first . . . impact tightening

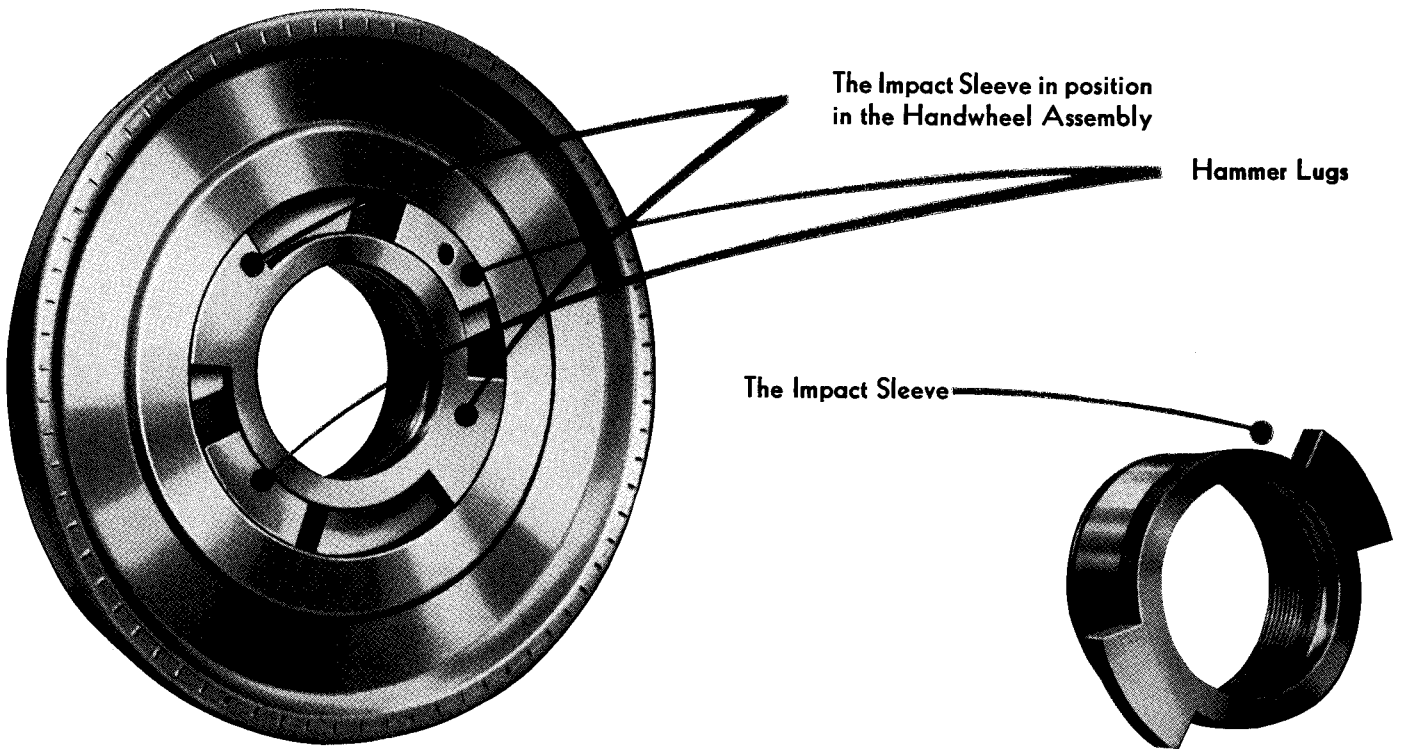

The Handwheel is used to draw the collet down firmly onto the bar. In order to establish the rugged grip of the collet, an impact or hammer blow, which travels through a 90° arc, is delivered onto the Impact Sleeve by the Handwheel hammer lugs. The force exerted is several times greater than that developed when a chuck is tightened down by hand. In order to open the collet, the impact blow is exerted in the reverse direction.

Even when tightened for your heaviest cuts, this chuck can be opened with very little physical effort — merely a flick of the wrist.

It is not necessary that the spindle be locked when tightening this chuck onto the bar — **IMPACT TIGHTENING ALLOWS SECURE CLOSING ON A FREE SPINDLE.**

The Jacobs handwheel operated chuck keeps the operator in front of his work — it eliminates reaching for draw-bar lever or wheel.

## IMPROVE THE PERFORMANCE AND CAPACITY OF ANY LATHE IN YOUR SHOP

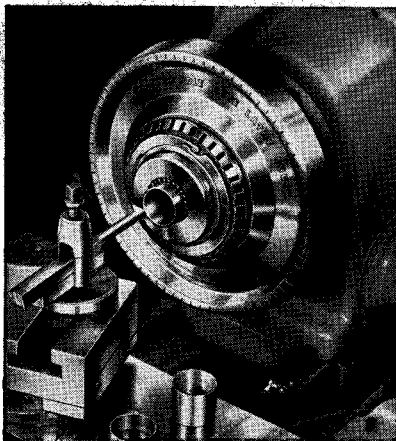

THIN SHELL PIECES

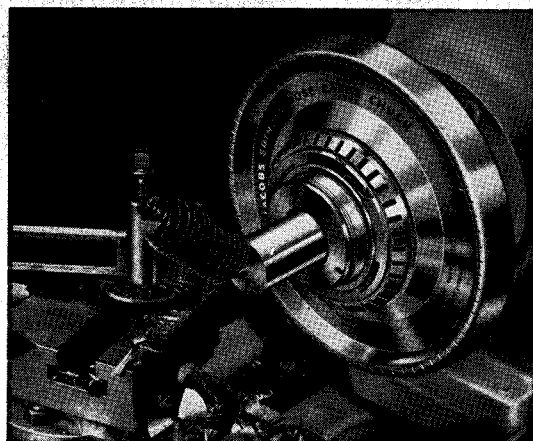

HEAVY DUTY TURNING

The great gripping area of this collet provides a rigid yet gentle hold on the work because the pressure at one point is no greater than at any other. In chucking the work it is kept perfectly round and will not develop an eccentric or out-of-round condition. This chuck is particularly adapted for holding **THIN WALLED PARTS, TUBING, FRAGILE MATERIALS, PLASTICS, WOOD, and SOFT METALS.**

Despite its very tight grip, this collet will not mar the surface of the part being chucked. Thin shelled pieces can be firmly held without distortion or crumpling.

**Simple construction - designed for years of rugged duty and low maintenance costs**

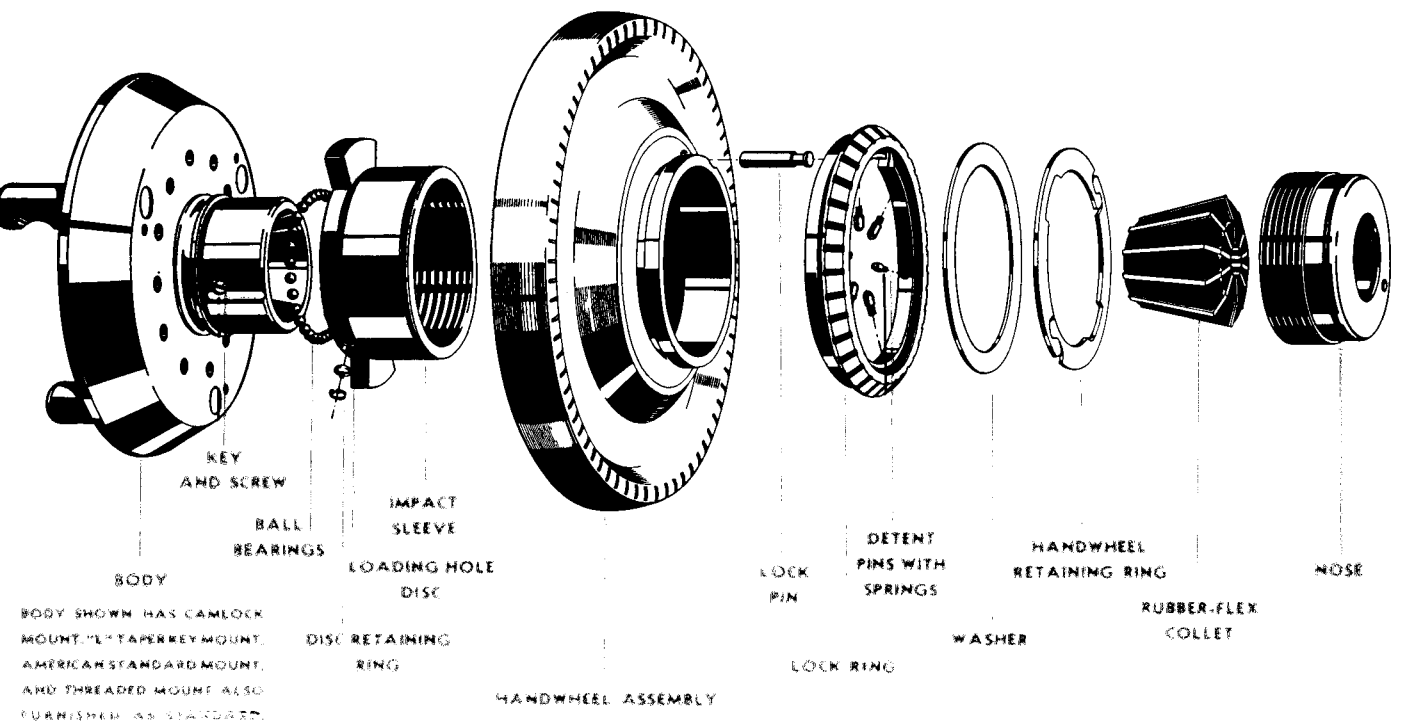

## Check these features!

The simple design and rugged construction reduces maintenance to a minimum. The chuck can be easily dismantled and assembled without endangering its accuracy or operation. Complete illustrated instructions covering operation and maintenance are supplied with each chuck.

In the above drawing, note that the chuck body which comprises the back mount and the collet seating cone is of one piece construction — machined from an alloy steel forging. This feature is largely responsible for the accuracy of this chuck.

The assembly drawing also clearly shows the hardened and ground Locking Pin which is attached to the Lock Ring and which passes through the Handwheel Assembly and seats in the Body. This device positively locks the chuck closed when in operation. We have purposely left enough stock in the collet seating cone so that should this surface ever become damaged the chuck can be returned for reconditioning.

## PARTS PRICE LIST

Part Name	Part Number	Price	Part Name	Part Number	Price
<b>Bodies for Models</b>			<b>Lock Ring Assembly (includes Detent Pins and Springs)</b>	R91	\$15.00
91-A6	B91-A6	\$115.00	<b>Washer</b>	W91	2.50
91-C3	B91-C3	110.00	<b>Truarc Handwheel Retaining Ring</b>	HR91	3.00
91-C4	B91-C4	110.00	<b>Rubber-Flex Collets (see back page)</b>		
91-C5	B91-C5	115.00	<b>Nose</b>	N91	30.00
91-C6	B91-C6	115.00	<b>Camlock Studs and Lock Screws</b>		
91-T00	B91-T00	110.00	Set of 3 for Model 91-C3	CS91-C3	4.75
91-T0	B91-T0	115.00	Set of 3 for Model 91-C4	CS91-C4	5.00
91-T1	B91-T1	135.00	Set of 3 for Model 91-C5	CS91-C5	5.50
91-F1	B91-F1	105.00	Set of 3 for Model 91-C6	CS91-C6	5.75
<b>Key and Screw</b>	G91	2.00	<b>Socket Head Cap Screws</b>		
<b>Ball Bearings with Loading Disc and Retaining Ring</b>	RP91	1.50	Set of 6 for Model 91-A6		1.00
<b>Impact Sleeve</b>	S91	35.00	(These are standard 1/2 x 13 x 1/4" Socket Head Cap Screws)		
<b>9" Handwheel Assembly</b>	HW91	70.00			
<b>7 1/2" Handwheel Assembly</b>	SHW91	70.00			
<b>Lock Pin</b>	SP91	1.50			

# Eleven collets cover the complete range of the chuck

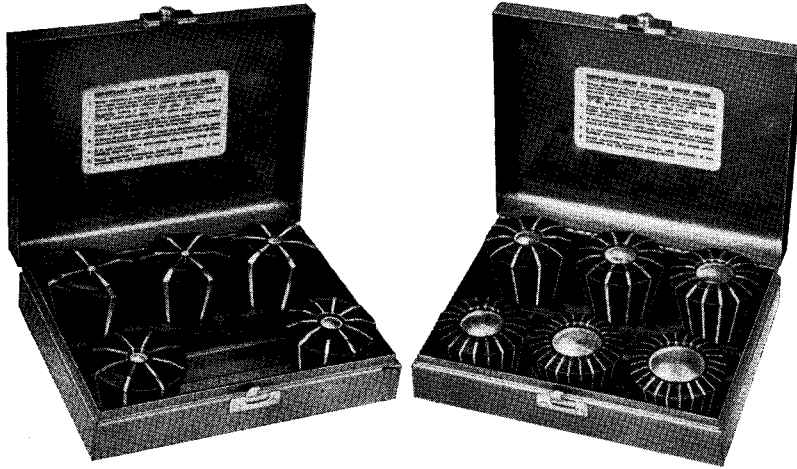

## ASSORTMENT "A"

This set of eleven collets (J-910 through J-920) will handle any fractional, decimal, or millimeter size bar between  $\frac{1}{16}$ " and  $1\frac{3}{8}$ " (1.6 millimeters and 35.0 millimeters). The set of collets is packed in two durable, compact, attractive, moisture resistant boxes, each of which measures 6" x 9" x 3". Provision has been made in the bottom of these boxes to allow the drilling of bolt holes to permit mounting these boxes to the lathe collet rack.

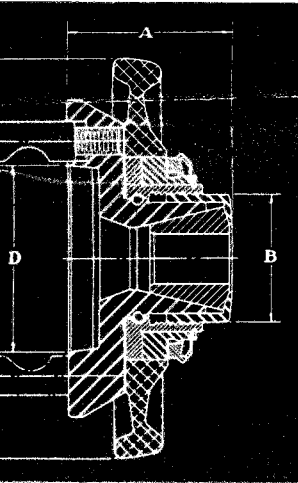

American Standard Camlock  
Type D1

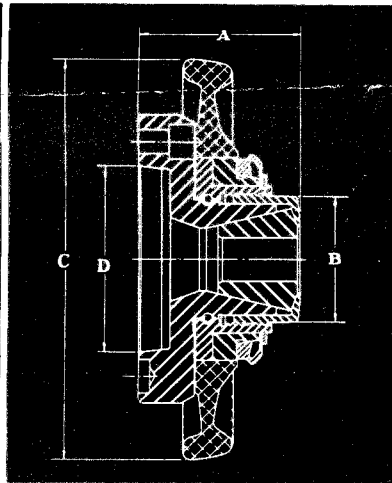

American Standard Type A2

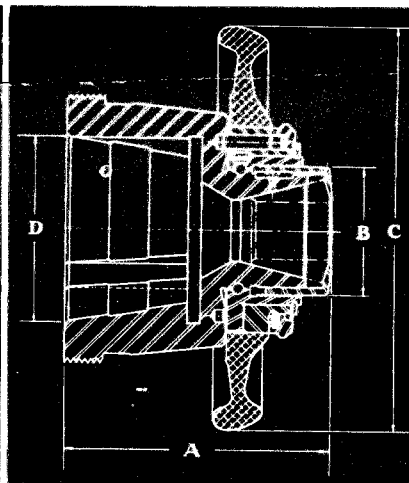

American Standard Taper Key  
Drive Type L

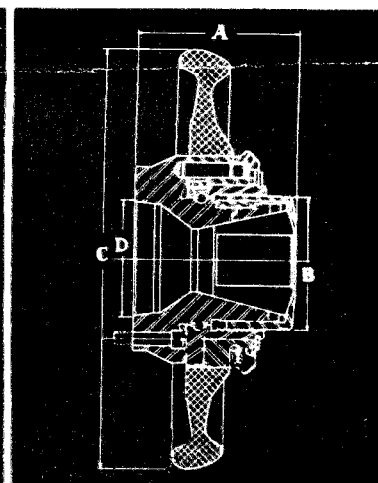

Model 91-F1 with 4"  
flange mount

Model No.	Type	A	B	C*	D	E**
91-C3	3" Camlock	3 $\frac{7}{16}$ "	2 $\frac{7}{8}$ "	9" or 7 $\frac{1}{2}$ "	2 $\frac{1}{8}$ "	2 $\frac{15}{16}$ "
91-C4	4" Camlock	3 $\frac{9}{16}$ "	2 $\frac{7}{8}$ "	9" or 7 $\frac{1}{2}$ "	2 $\frac{1}{2}$ "	3 $\frac{1}{16}$ "
91-C5	5" Camlock	4"	2 $\frac{7}{8}$ "	9"	3 $\frac{1}{4}$ "	3 $\frac{1}{2}$ "
91-C6	6" Camlock	3 $\frac{3}{4}$ "	2 $\frac{7}{8}$ "	9"	4 $\frac{3}{16}$ "	3 $\frac{1}{16}$ "
91-T1	L1 Taper Key	6"	2 $\frac{7}{8}$ "	9"	4 $\frac{1}{8}$ "	3 $\frac{1}{4}$ "
91-T0	L0 Taper Key	5 $\frac{3}{8}$ "	2 $\frac{7}{8}$ "	9" or 7 $\frac{1}{2}$ "	3 $\frac{1}{4}$ "	3 $\frac{1}{8}$ "
91-T00	L00 Taper Key	5"	2 $\frac{7}{8}$ "	9" or 7 $\frac{1}{2}$ "	2 $\frac{3}{4}$ "	3 $\frac{1}{8}$ "
91-A6	6" Am. Std.	3 $\frac{3}{4}$ "	2 $\frac{7}{8}$ "	9"	4 $\frac{3}{16}$ "	2 $\frac{15}{16}$ "
91-F1	4" Flange Mount	3 $\frac{9}{16}$ "	2 $\frac{7}{8}$ "	9" or 7 $\frac{1}{2}$ "	2 $\frac{1}{2}$ "	3 $\frac{1}{16}$ "

\* A 7 $\frac{1}{2}$ " Handwheel can be supplied as optional equipment at no extra charge and this handwheel makes an excellent application when clearance is limited. The 7 $\frac{1}{2}$ " Handwheel can only be used on the models indicated. Wherever clearance permits, the 9" Handwheel should be used as it provides maximum gripping power.

\*\* Shows distance chuck extends beyond spindle nose at maximum capacity. Extension is  $\frac{5}{16}$ " less when collet is at minimum capacity.

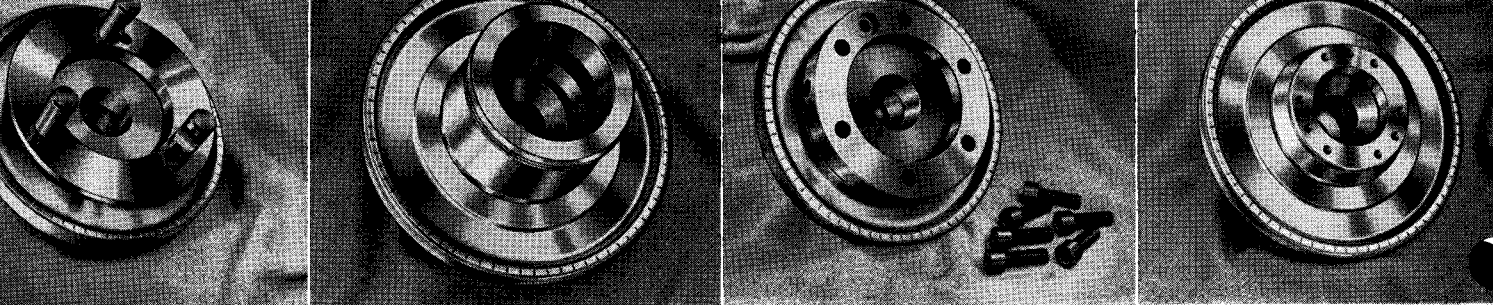

For American Standard Camlock Spindles Type D1

For American Standard Taper Key Drive Spindles Type L

For American Standard Spindles Type A2 and threaded Spindles

Model 91-F1 with 4" flange mount recommended for special applications including small diameter threaded Spindles.

## CHUCK PRICES

Model Number	Spindle Mount	Capacity	Weight Lbs. Ozs.	Metric Capacity	Price
<b>FOR AMERICAN STANDARD CAMLOCK SPINDLES TYPE D1</b>					
91-C3	D1-3" Camlock	1/16" — 1 3/8"	11 — 8	1.6 MM — 35.0 MM	\$240.00
91-C4	D1-4" Camlock	1/16" — 1 3/8"	12 — 9	1.6 MM — 35.0 MM	245.00
91-C5	D1-5" Camlock	1/16" — 1 3/8"	17 — 2	1.6 MM — 35.0 MM	250.00
91-C6	D1-6" Camlock	1/16" — 1 3/8"	18 — 8	1.6 MM — 35.0 MM	250.00
<b>FOR AMERICAN STANDARD TAPER KEY DRIVE SPINDLES TYPE L</b>					
91-T00	L00 Taper Key Drive	1/16" — 1 3/8"	14 — 8	1.6 MM — 35.0 MM	240.00
91-T0	L0 Taper Key Drive	1/16" — 1 3/8"	25 — 0	1.6 MM — 35.0 MM	250.00
91-T1	L1 Taper Key Drive	1/16" — 1 3/8"	30 — 8	1.6 MM — 35.0 MM	270.00
<b>FOR AMERICAN STANDARD SPINDLES TYPE A2</b>					
91-A6	American Standard A2-6"	1/16" — 1 3/8"	18 — 8	1.6 MM — 35.0 MM	250.00
<b>FOR THREADED SPINDLES</b>					
91-A6	Threaded or Special Mount	1/16" — 1 3/8"	18 — 8	1.6 MM — 35.0 MM	250.00
91-F1	Threaded or Special Mount	1/16" — 1 3/8"	11 — 8	1.6 MM — 35.0 MM	240.00

Model 91-A6 is recommended when the spindle thread O.D. is 2 1/16" or larger.

Model 91-F1 is suggested when mounting on threaded spindles having a thread O.D. of 2" or smaller.

## ADAPTERS

Because of the small diameter of the flange on chuck model 91-F1, no blank is supplied for making the adapter, however it can be readily made up from any 4" diameter bar in accordance with our instructions furnished with the chuck.

An adapter plate casting (model AD6T) for mounting model 91-A6 on threaded spindles can be furnished at a price of \$5.00. This adapter is rough-machined, but in order to secure the full accuracy of our chuck the adapter should be finished on the spindle of the machine upon which it will be ultimately used. The threaded machine tool spindle acts as the gauge. Complete machining instructions furnished with each chuck and also upon request.

## RUBBER-FLEX<sup>®</sup> COLLET PRICES

Model Number	Capacity (Inches)	Capacity (Metric)	Price
J-910	1/16" — 1/8"	1.6 MM — 3.2 MM	\$ 14.50
J-911	1/8" — 1/4"	3.2 MM — 6.4 MM	14.50
J-912	1/4" — 3/8"	6.4 MM — 9.5 MM	14.50
J-913	3/8" — 1/2"	9.5 MM — 12.7 MM	14.50
J-914	1/2" — 5/8"	12.7 MM — 15.9 MM	14.50
J-915	5/8" — 3/4"	15.9 MM — 19.0 MM	14.50
J-916	3/4" — 7/8"	19.0 MM — 22.2 MM	14.50
J-917	7/8" — 1"	22.2 MM — 25.4 MM	14.50
J-918	1" — 1 1/8"	25.4 MM — 28.6 MM	14.50
J-919	1 1/8" — 1 1/4"	28.6 MM — 31.8 MM	14.50
J-920	1 1/4" — 1 3/8"	31.8 MM — 35.0 MM	14.50

ASSORTMENT "A" (See page 7)

A complete set of collets (J-910 through J-920) packed in two boxes containing the molded Rubber Collet Plugs.

\$139.50

### HEXAGON AND SQUARE COLLETS

Hexagon Collets are available from 1/4" to 1" by 1/16ths. Square Collets are available from 1/4" to 3/4" by 1/16ths. Both Hexagon and Square Collets in these listed sizes are priced at \$16.00 each. These collets are of split steel construction and are designed to be used on lathes whose spindle hole I.D. is 1 3/8" or larger.

### RUBBER COLLET PLUGS

CP012	(for use with J-910, J-911 and J-912 Collets)	\$.75
CP913-CP914	(for use with J-913 and J-914 Collets)	.75
CP915-CP916	(for use with J-915 and J-916 Collets)	.75
CP917-CP918	(for use with J-917 and J-918 Collets)	.75
CP919-CP920	(for use with J-919 and J-920 Collets)	.75

### COLLET BOXES

CB1	(Collets J-910 through J-914)	\$5.00
CB2	(Collets J-915 through J-920)	5.00

The Jacobs Spindle Nose Lathe Chuck and Rubber-Flex Collets are protected by the following United States and Foreign Patents:

UNITED STATES	CANADIAN	GERMAN	BRITISH	BELGIAN	FRENCH	JAPANESE
2,346,706	Patented	829,397	584,258	506,293	Brevete S.G.D.G.	200,194
2,346,707	1946, 1947, 1951	845,890	617,964		912,726	
2,459,899		859,400	672,006	BRAZILIAN		
2,459,900				31,959	SWEDISH	AUSTRIAN
					125,251	186,947