

INSTRUCTION & PARTS MANUAL

HARRISON Model 10-AA high-speed precision lathe

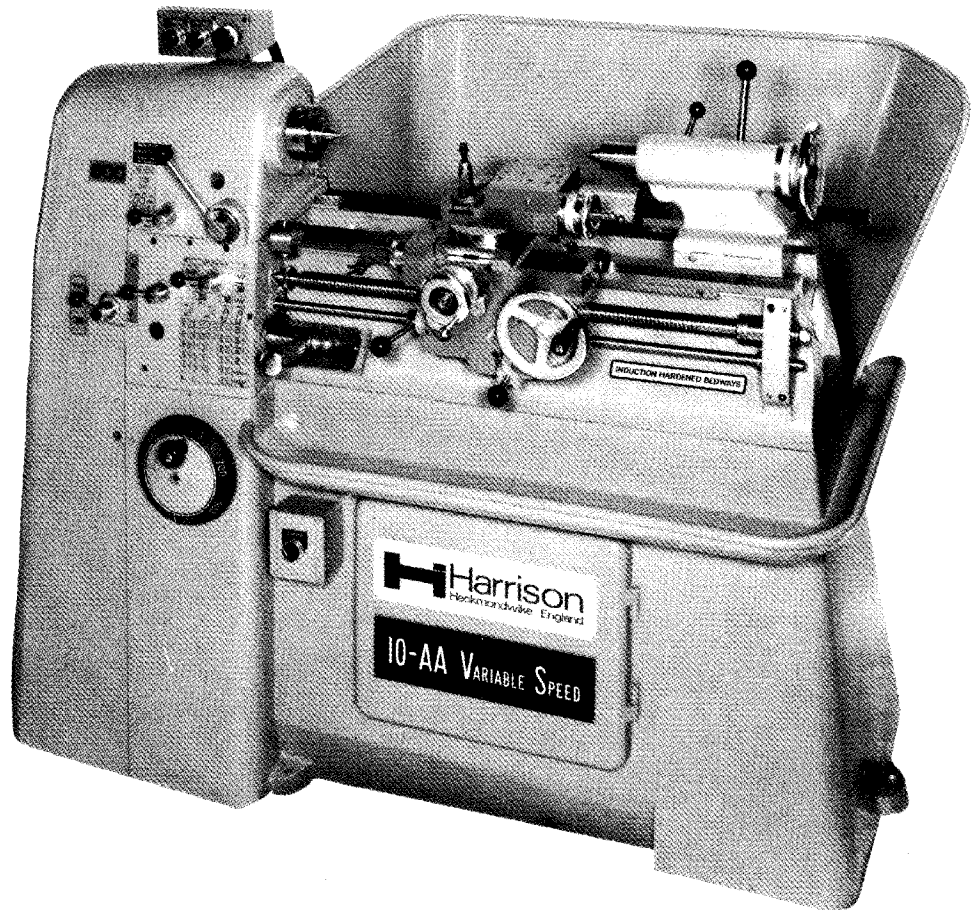

This manual applies only to the machine having the serial number shown; this is carried on a red disc affixed on each major assembly and must be quoted in all communications regarding the lathe or repair parts.

Machine serial number

Printed in England

REM SALES INCORPORATED
WEST HARTFORD - CONNECTICUT 06107

INDEX

	Page
Specification	3
Know your lathe	4
Foundation Plan	5
Installation	
Cleaning	6
Lifting	6
Installing	6
Electric supply connection	6
Lubrication checks	7
Chuck mounting	7
Operation	
Lathe controls	8
Electrical controls	8
Speed controls	9
Threads and feeds	9
Threads available	10
Threading dial indicator	10
Special and multi-start threads	10
Multi-start thread cutting	10
Apron	10
Carriage	11
Tailstock	11
Lathe Bed	11
Coolant system	12
Soluble oil emulsions	12
Soluble oil & machine maintenance	12
Bed alignment	13
Headstock alignment	13
Tailstock alignment	13
Servicing and Maintenance	
End gears	14
Shear pin	14
Lubrication	15
Lube grades	15
Lubrication chart	16
Wiring diagram	17
Variable speed unit	18
Accessory list and details	19
Repair parts section	
Appendix 1 - standard items	

SPECIFICATION

CAPACITIES

Height of centres	5 $\frac{5}{8}$ in
Swing	
Over bed	11 $\frac{1}{4}$ in
Over cross slide	7 in
Distance between centres	20 in
Diameter of faceplate	10 $\frac{5}{8}$ in
Diameter of driving plate	6 in
Capacity of travelling steady	1 $\frac{3}{8}$ in
Overall length	59 $\frac{1}{4}$ in
Overall width	29 in
Approximate weight	1148 lb

HEADSTOCK

Spindle bore (Max. bar dia.)	1 $\frac{3}{8}$ in
Spindle nose, Camlock	3 in D.I.
Taper in spindle nose bush	No. 3 M.T.
Spindle speeds - infinitely variable	35-3000 r.p.m.

CARRIAGE

Total travel of cross slide	6 $\frac{3}{8}$ in
Total travel of top slide	3 $\frac{3}{8}$ in
Height from top of topline to centre line of spindle	1 $\frac{1}{8}$ in
Max. tool shank size	$\frac{1}{2}$ in x 1 in

THREADS AND FEEDS

Pitch of leadscrew	4 t.p.i.
Number of threads	44
Range	2-120 t.p.i.
Number of feeds	27
Range per rev. of spindle—	
Longitudinal	0.001 in-0.008 in
Cross	0.0005 in-0.004 in

TAILSTOCK

Spindle travel (No. 3 M.T. Centre fitted) ...	4 in
Spindle travel (Standard tang drill fitted)	3 $\frac{1}{2}$ in
Taper in spindle	No. 3 M.T.

DRIVE

2 h.p. continuously rated single speed motor driving Kopp variable speed unit of 9:1 ratio.

STANDARD EQUIPMENT SUPPLIED WITH THE MACHINE

One 10" diameter faceplate
 One 6" diameter driving plate
 Two No. 3 Morse taper centres
 Centre bush
 Travelling steady
 Spanners and keys

(for details of accessories see page 19.)

KNOW YOUR LATHE

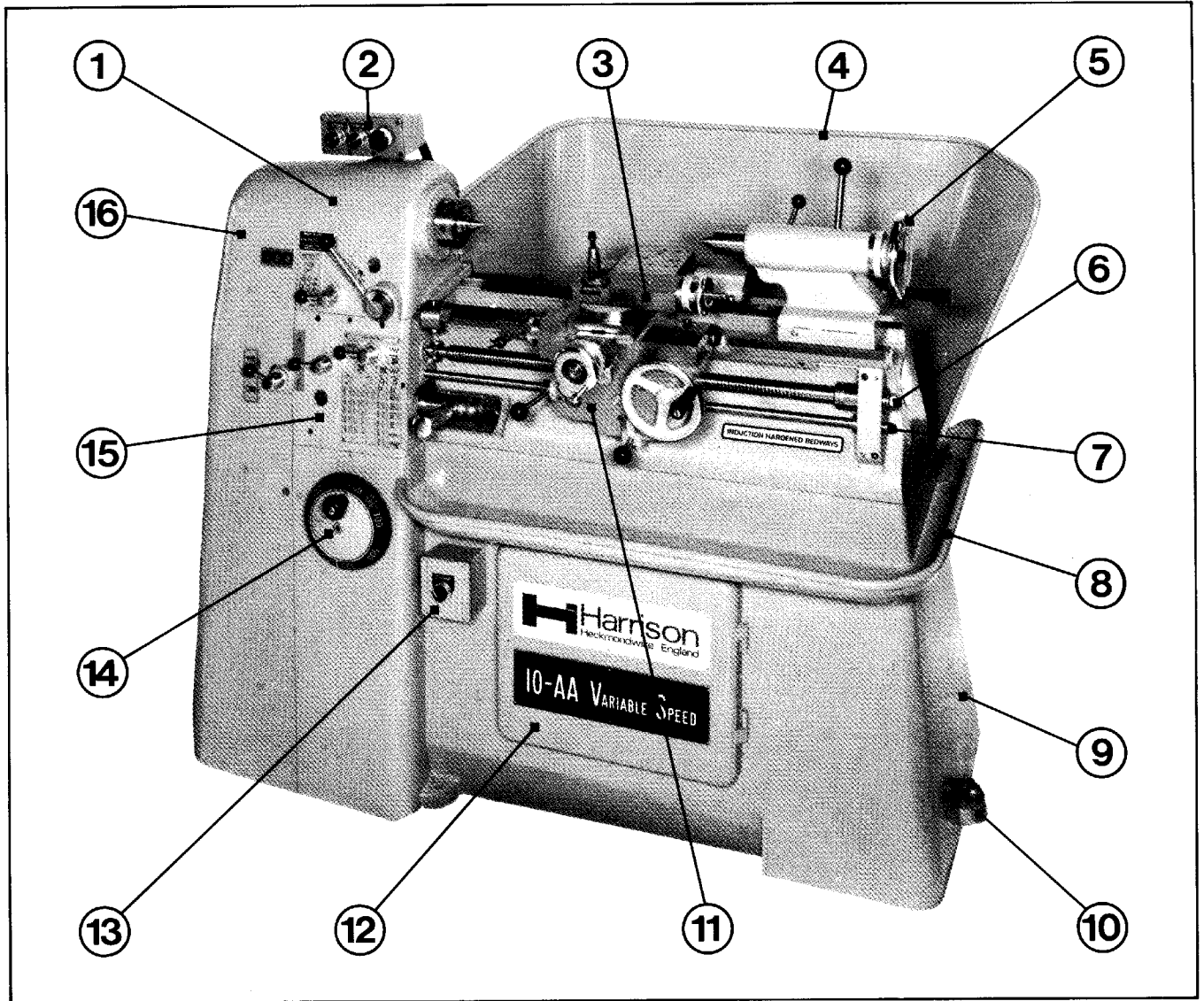

Fig.1

LEGEND

- | | |
|------------------------|--------------------|
| 1. Headstock | 9. Cabinet base |
| 2. Electrical controls | 10. Mounting feet |
| 3. Carriage | 11. Apron |
| 4. Splashguard | 12. Cupboard |
| 5. Tailstock | 13. Coolant switch |
| 6. Leadscrew | 14. Speed control |
| 7. Splineshaft | 15. Gearbox |
| 8. Coolant tray | 16. Endguard |



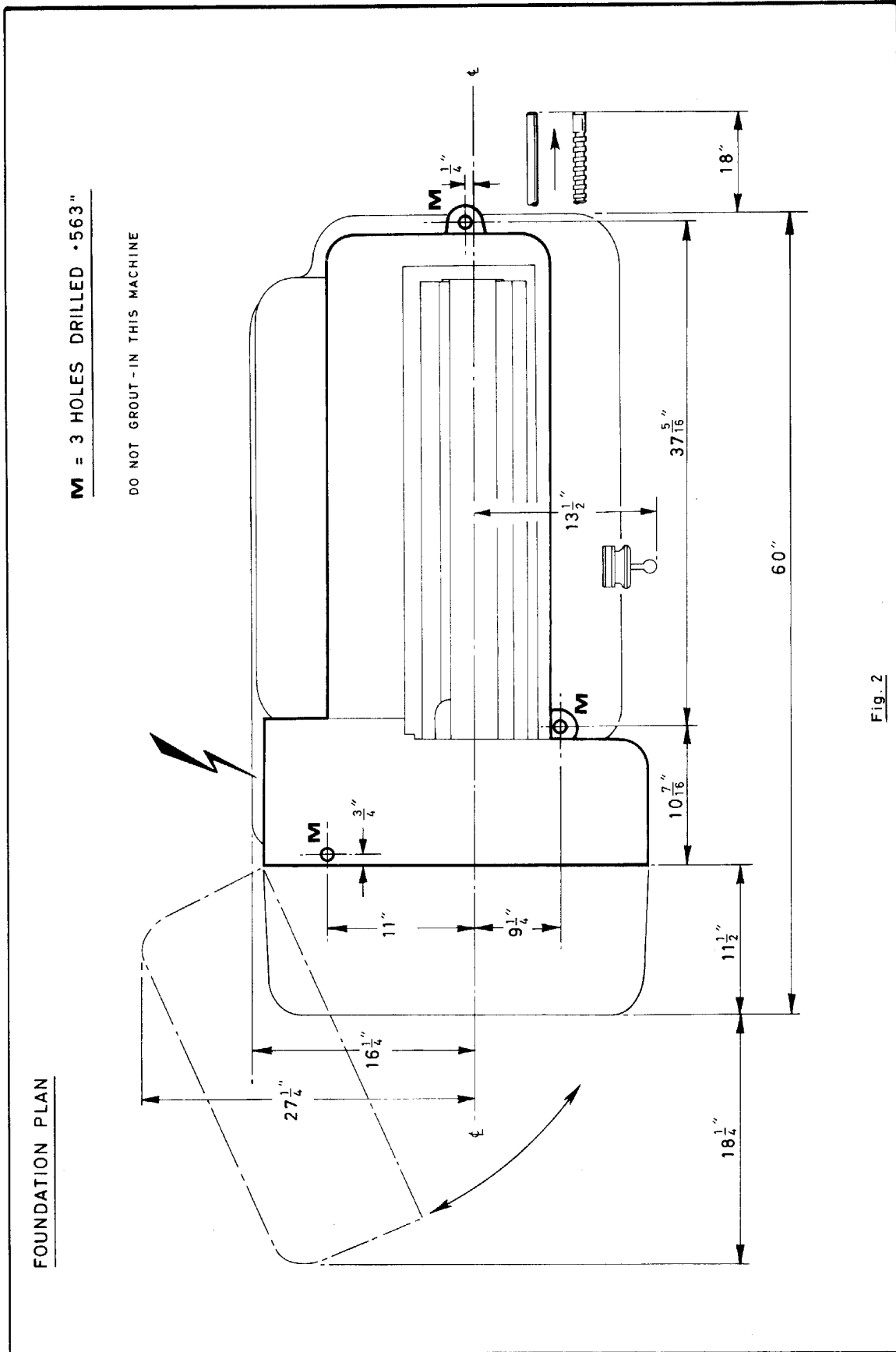

Fig. 2

Fig. 2

CLEANING

Before operating any controls, remove the anti-corrosion coating from all slideways and from end-gear train, Fig. 3.

Use white spirit or kerosene for cleaning.

DO NOT USE CELLULOSE SOLVENTS FOR CLEANING AS THESE CAN DAMAGE THE PAINT FINISH.

Oil all bright machined surfaces immediately after cleaning using machine oil or way lubricant; oil end-gears and apply oil can to oiler on idler gear stud. Note: remove silica-gel bag from matrix clutch.

LIFTING

Use the cross-bar immediately in front of the headstock for lifting, see Fig. 4. Position saddle and tailstock along bed to obtain balance before lifting. Under no circumstances use a pinch-bar for manoeuvring the machine.

IMPORTANT: DO NOT SLING FROM ANY OTHER POINT.

INSTALLING

Locate the lathe on a solid foundation allowing sufficient area all round for easy working and maintenance, bearing in mind that swarf removal is from the back. Main dimensions and recommended minimum area for efficient operation are shown on the Foundation Plan, Fig. 2. The lathe may be used free standing or bolted to the foundation.

Free-standing: Position lathe on the foundation, then raise it and set the compound-rubber pads under the mounting bases (M) Fig. 5. As the lathe normally stands firmly on three feet no further levelling should be necessary.

Fixed-installation: Position lathe over three 1/2 in. bolts set to dimensions shown in the Foundation Plan (Fig. 2). Pierce the mounting pads to enable bolts to pass through. Tighten bolts evenly, then with a precision level across the bedway check that lathe stands true.

THE MACHINE SHOULD NOT BE GROUTED-IN.

ELECTRIC SUPPLY CONNECTION

Power supply should be connected to mains terminals of the disconnect box at the back of the headstock. It is essential to provide an efficient ground (earth), as shown in the Wiring Diagram (see Servicing & Maintenance Section).

The lathe spindle must rotate in forward direction when the Forward selector button is pressed and clutch lever (Fig. 9) is set to the right. To rectify incorrect rotation, interchange any two phase lines.

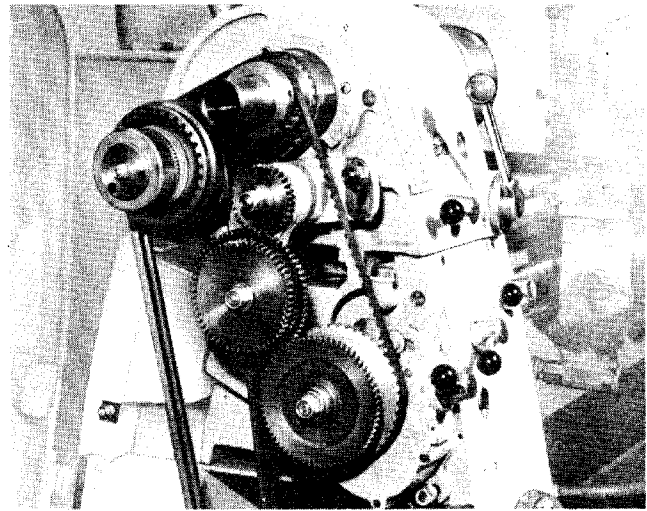

Fig. 3

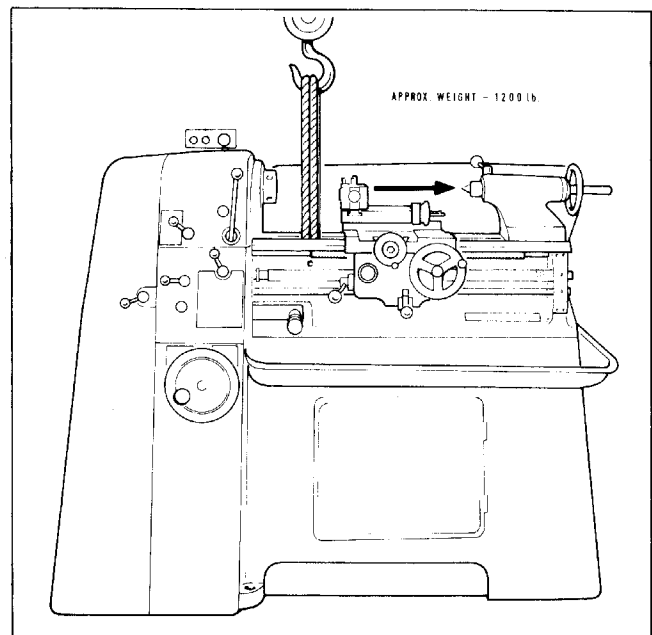

Fig. 4

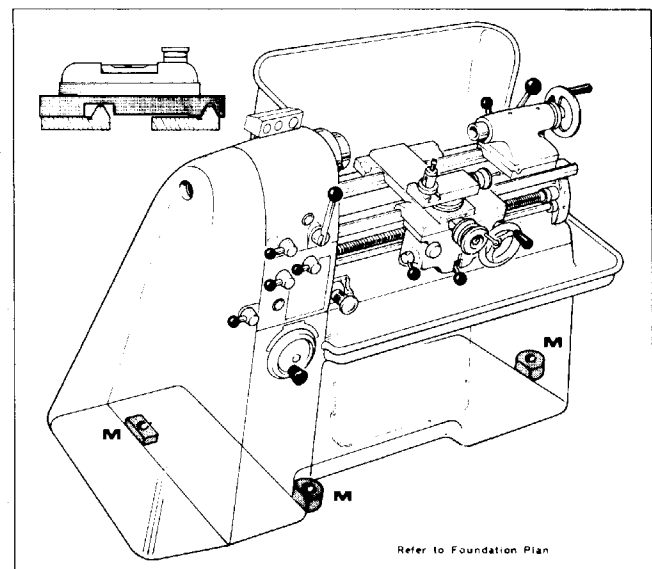

Fig. 5

LUBRICATION CHECKS

Before attempting to start the machine make the following important checks:—

1. That headstock is filled to correct level (sight glass) with Shell Tellus Oil 15.
2. That gearbox is filled to correct level (sight glass) with Shell Tellus Oil 33.
3. That variator is filled to correct level (sight indicator) with Shell Tellus Oil 15.
4. That carriage apron is filled to correct level (sight glass) with Shell Tonna Oil 33.
5. That saddle-lubrication reservoir is topped up with Shell Tonna Oil 33 and thumb-pump operates (see page 15).
6. Apply oil can to the points shown on Lubrication Diagram requiring daily attention. Use light machine oil or way-lubricant.

CHUCK MOUNTING

When fitting chucks or faceplates, first ensure spindle and chuck tapers are scrupulously clean and that all cams lock in the correct position, Fig. 6.

It may be necessary when fitting a new chuck to reset the camlock studs (A). To do this; remove the locking screws (B) and set each stud so that the scribed ring (C) is flush with the rear face of the chuck, with the slot aligned with the lock-screw hole (inset, Fig. 6).

Mount the chuck or faceplate on the spindle nose and tighten the three cams in turn. When fully tightened, the cam lock line on each should be between the two Vee marks (Fig. 6). If any cam does not tighten fully within these marks, remove chuck or faceplate and re-adjust the stud as indicated. Fix and tighten the lock screw (B) at each stud before remounting the chuck.

A reference mark should be made on the correctly fitted chuck or face-plate to coincide with the reference mark scribed on the spindle nose. This will assist subsequent remounting.

DO NOT INTERCHANGE CHUCKS OR FACE-PLATES BETWEEN LATHES WITHOUT FIRST CHECKING FOR CORRECT CAM LOCKING.

Fig. 6

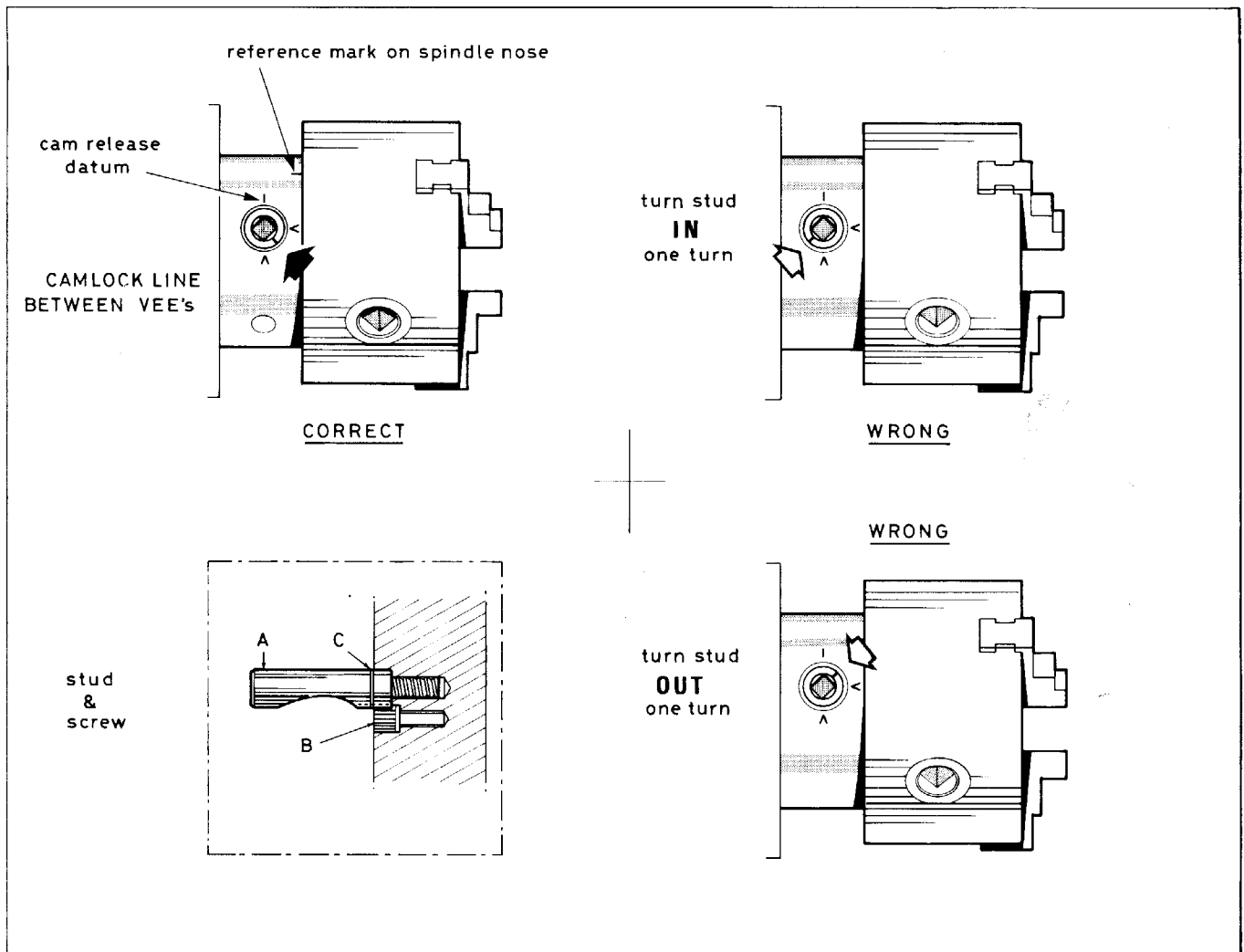

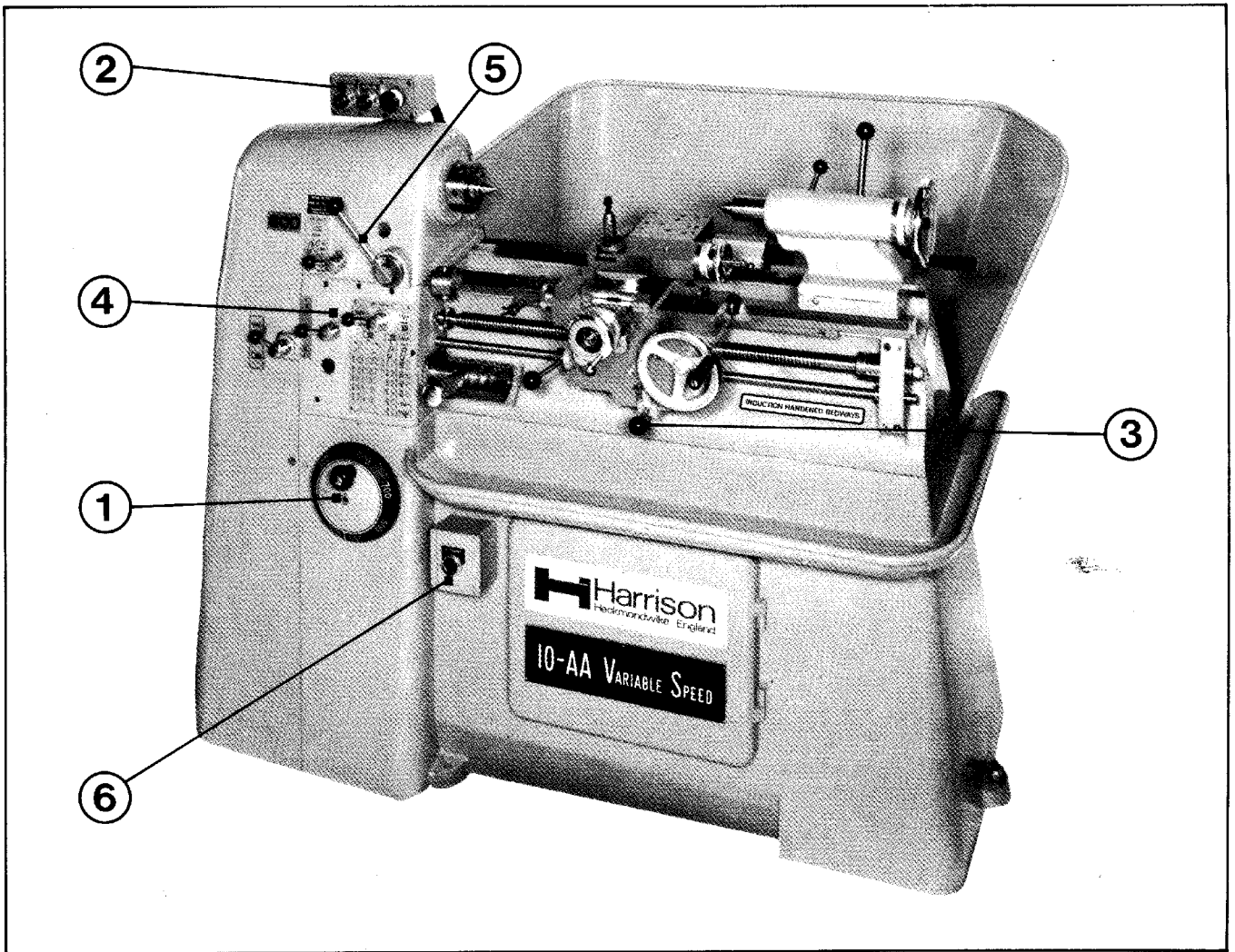

Fig.7

LATHE CONTROLS (Fig. 7)

1. Spindle speed selector
2. Electrical push buttons
3. Apron, surfacing or sliding feeds
4. Gearbox, threads and feeds
5. Spindle rotation
6. Coolant pump switch

ELECTRICAL CONTROLS (Fig. 8)

With exception of the disconnect switch, all electrical controls are accessible from the front of the lathe.

To start main motor:—

1. Press FORWARD button (on headstock panel) for forward rotation.
2. Press REVERSE button for reverse rotation.
3. Press the RED mushroom-head button to stop the main motor and also electrical supply to ancillary services.
4. Coolant pump ON/OFF switch.

Fig. 8

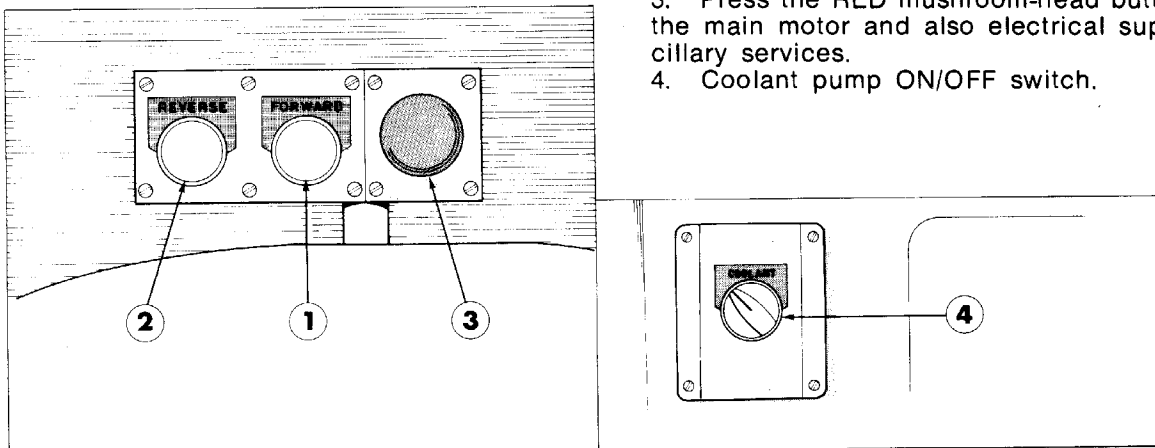

SPEED CONTROLS

Speed Range is selected by lever (C), See Fig. 9. Move the lever out and up for low-speed range (35 to 300 rev/min) through the geared headstock. Move lever out and down for high-speed range (350 to 3000 rev/min) through direct belt-drive from clutch to main spindle.

DO NOT ATTEMPT TO MOVE THIS LEVER WITH THE MAIN SPINDLE ROTATING. A SAFETY LOCK PREVENTS INADVERTANT OPERATION.

Speed Selection rotate the handwheel speed-selector (1 of Fig. 7) on the front of the cabinet to obtain the desired speed. **DO NOT OPERATE WHILST THE MAIN MOTOR IS AT REST.** A slipping clutch is incorporated in the selector mechanism to prevent damage to the variable speed unit through inadvertant operation.

Spindle Rotation: is achieved by moving lever (B) Fig. 9. Move the lever out and upward to engage the drive clutch. To disengage, move the lever left and downward to the safety-lock position. Further downward pressure on the lever in this position will operate the retarding brake.

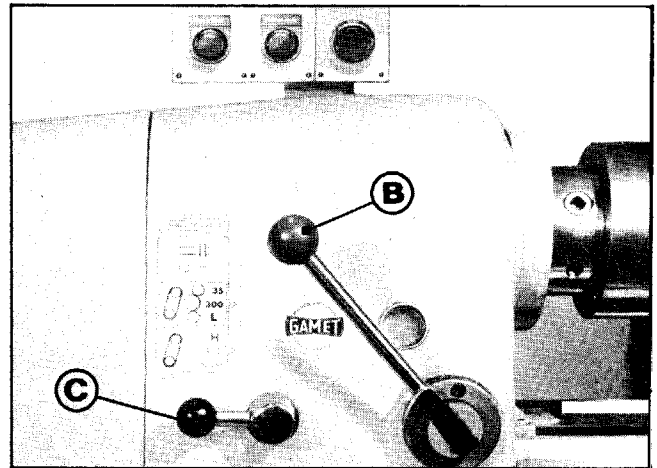

Fig. 9

* * *

THREADS AND FEEDS

All threads and feeds directly available through the gearbox are shown on the data plate fitted on the gearbox, Fig. 10.

Control of the gearbox is by three levers and a tumbler shaft, Fig. 11.

To select threads and feeds; set the tumbler shaft (5) in conjunction with selector lever (1) in accordance with data plate directions, engaging the tumbler shaft in the slotted tumbler bearing extension to the right of the gearbox.

Lever (3) is used in conjunction with the speed range selector (C of Fig. 9) to transmit drive from the end train. For coarse, multi-start or special threads set lever (C) to position L and lever 3 to the lower position — threading only. Standard fine threads to 16 t.p.i. single start may be cut with lever (C) set to position H and lever 3 to the upper position — threads and feeds.

Lever (2) reverses the direction of rotation of leadscrew and feedshaft. A dog-clutch (4) is provided for disengaging the leadscrew, which should not be engaged except when thread-cutting.

SPINDLE AND HEADSTOCK GEARING MUST BE STOPPED BEFORE ANY GEARBOX LEVERS ARE MOVED.

SMELL TELLUS OIL 33

60 LC9	14 LA8 LCB	3 1/2 LA7	80 HC4	0016 HC9
56 LCB	13 LA7 LCB	3 LA6	72 HC2	0012 HC7
48 LC6	12 LA6 LC6	2 3/4 LA5	64 HC1	0013 HC6
44 LC5	11 LA5 LC5	2 1/2 LA4	60 HB9	002 HC1
40 LC4	10 LA4 LC4	2 LA1	56 HB8	0028 HB7
36 LC2	9 LA2 LC2		48 HB6	003 HB6
32 LC1	8 LA1 LC1		44 HB5	0038 HB3
28 LBB	7 1/2 L — LBP		40 HB4	004 HB1
26 LB7	7 — LBB		36 HB2	005 HA7
24 LB6	6 — LB6		32 HB1	006 HA6
22 LB5	5 — LB4		28 HA8	007 HA3
20 LB4	4 1/2 — LB2		26 HA7	008 HA1
19 LB3	4 — LB1		24 HA6	1/2
18 LB2	3 1/2 — LA9		22 HA5	
16 LB1	3 1/2 — LA8		20 HA4	
			19 HA3	
			18 HA2	
			16 HA1	

Fig. 10

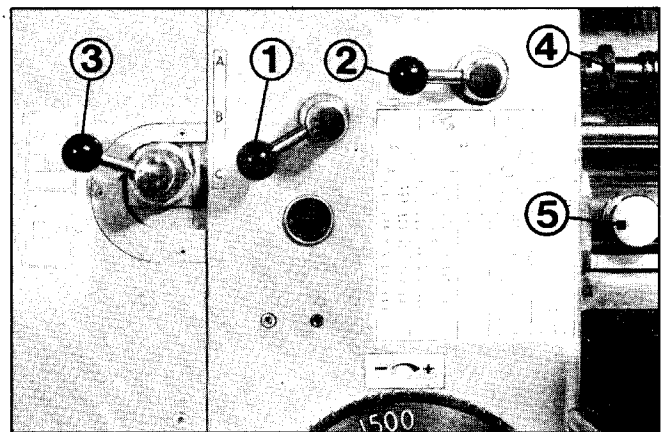

Fig. 11

THREADS AVAILABLE

44 Whitworth 2 - 120 t.p.i.
 14 Metric 0.5 - 12 mm

Metric pitches can be obtained by compounding the end-gear train as shown on the separate data plate fixed to the lathe endguard.

THREADING DIAL INDICATOR

Located on front face of the apron (D) Fig. 12. To cut threads of even number per inch close the leadscrew nut as ANY line passes the datum mark. To cut threads of odd numbers per inch close the leadscrew nut on any numbered line. Fractional threads of 1/2 or 1/4 t.p.i. may be cut by closing the nut at the same numbered line at each pass of the tool.

The dial cannot be used in cutting metric threads, D.P., module pitches nor fractional threads other than those shown. For these, the leadscrew nut must be kept closed and the machine reversed by the switch button on the headstock after each cut and tool withdrawal.

SPECIAL AND MULTI-START THREADS

To cut special or multi-start threads, where special change gears may be required the following formula is used:—

$$\frac{\text{DRIVERS}}{\text{DRIVEN}} = \frac{X}{Y \times \text{threads per inch}}$$

Where X = 16, 18, 19, 20, 22, 24, 26, 28 or 30
 (Corresponding to hole locations 9, 8, 7, 6, 5, 4, 3, 2, or 1. and Y = lever position: a = 4, b = 2, c = 1.

Example: Required to cut 11 1/2 t.p.i.

Choose X = 22, then $\frac{22}{4 \times 11\frac{1}{2}} = \frac{11}{23} = \frac{33}{69}$

33T is the standard change wheel, therefore a 69T gear will be required.

MULTI-START THREAD CUTTING

These can be cut in three ways:—

(a) by repositioning the compound slide one pitch forward for each start. Accuracy, however, depends upon operators experience.

(b) by using an accurately-divided driver plate and turning the workpiece one division forward for each start.

(c) by advancing the driver gear a calculated number of turns to advance the spindle by one pitch of the thread to be cut. The accuracy of this method is that of the machine.

The ratio between spindle and driver gear shaft is 2 : 1 i.e. for 1 revolution of the spindle the driver gear shaft rotates 2 revolutions.

To use this method, therefore, the number of teeth in the driver gear must be divisible by the number of starts required. The driver gear is then advanced by twice this number of teeth to cut each thread start.

Example:—Required to cut 3-Start thread.

Cut one start. Mark meshing teeth on all gears. Count number of teeth in driver gear; if there are, say, 33 teeth mark the 22nd tooth $\frac{(33 \times 2)}{2}$ from the

original mark. Remove the idler. Turn driver to mark on 22nd tooth and re-mesh idler. Check the marks. Then cut the next start and repeat process for third start.

It must be appreciated that although this last is the best method to use, in certain cases the number of starts may not be a factor of the number of teeth in the driver gear. In such cases a choice must be made of methods (a) and (b).

Fig. 12

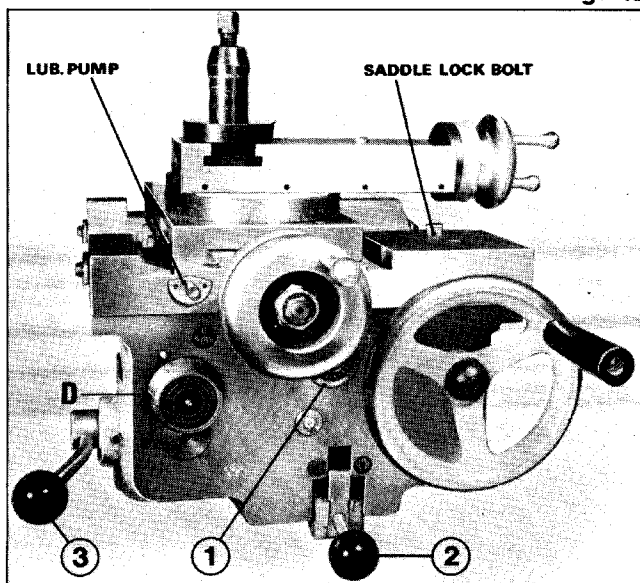

APRON

In addition to handwheel-traverse the carriage can be power-operated through apron controls, see Figs. 12 and 13.

Surfacing and sliding feeds are selected by plunger (1) Fig. 12, surfacing (cross) feeds with the plunger fully extended and sliding (longitudinal) feeds with the plunger fully depressed. Power feed is engaged by raising lever (2) to the latched position. This engages a wormbox which incorporates a safety device to prevent overloading. It also permits the use of feed stops which automatically disengage the feed mechanism on contact with a pre-set limit stop.

CARRIAGE

The carriage is secured to the bed by adjustable gibs at front and rear. It can be locked on the bed in any position by the saddle lock bolt, Fig. 12.

A slotted topslide is fitted to the crossslide, carried on a rotatable base which is marked 90-0-90 degrees for accurate indexing, Fig. 13.

The American pillar-type toolpost is fitted as standard equipment, suitable for $\frac{1}{2}$ in. x 1 in. tooling.

Handwheel dials are graduated in 0.001 in. divisions.

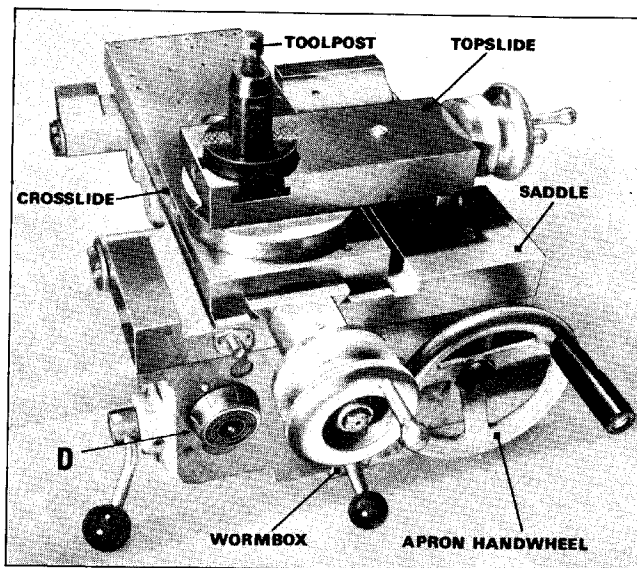

Fig. 13

TAILSTOCK

Can be freed for movement along the bed by unlocking the clamp lever B (Fig. 14). The barrel is clamped by lever C.

The tailstock can be set over for production of shallow tapers or re-alignment. Release the bed clamp lever and adjust the set-over screws to move the tailstock laterally across the base. An indication of set-over is given by the datum mark on the tailstock end face. Apply the bed clamp lever after adjustment and before using the tailstock.

The barrel is graduated in inch divisions and has a No. 3 Morse taper bore. All standard tang drills are driven by the tang and eject at zero graduation. A tool-height indication line is scribed on the barrel to assist in correct setting of tools to lathe centre height when workpiece is held between centres.

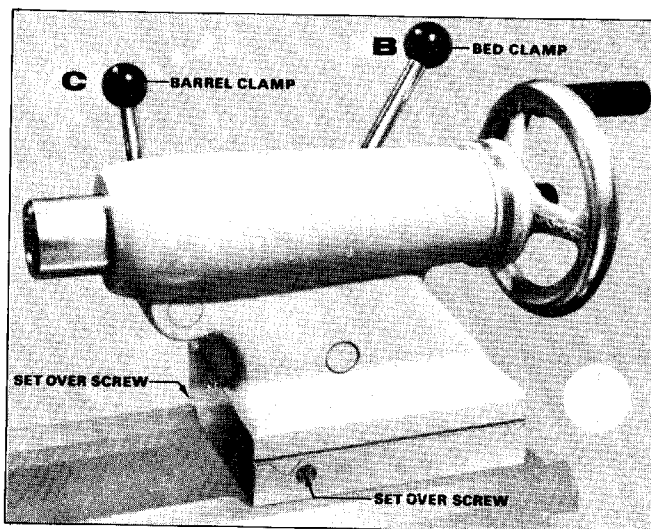

Fig. 14

LATHE BED

The bed is a seasoned casting with all bearing surfaces induction hardened and precision ground. The pyramid construction gives great rigidity under the heaviest cutting conditions and the ported openings provide for easy fall of chips and coolant to the rear of the machine. The front wall of the bed is shaped and recessed to provide maximum protection for the leadscrew and feedshaft. A ground pad with tapped holes is provided on the rear face for the mounting of either a taper turning attachment or hydraulic profiling unit without the need for skilled fitting. The bed casting is mounted on a heavy cabinet base, also of pyramid design, which incorporates a suds tray and two-shelf cupboard and housing the drive unit.

COOLANT SYSTEM

The bed and cabinet are so designed that swarf and coolant fall away into a disposal area in back of the lathe, with the coolant sump at the head-stock end fitted with a perforated cover to prevent ingress of swarf.

The electric pump has a separate switch box mounted beneath the tray at the front of the lathe (see Fig. 1) power being supplied from the main electrical panel (refer to Wiring Diagram for details).

The pump motor must be switched off if the sump runs dry or if coolant is not used for long periods. Clean out the sump at regular intervals. Avoid splashing coolant over the pump when refilling.

Coolant can be fed to any required position through a universal delivery system controlled by a ball-valve. The standpipe is attached to the back of the saddle and connected to the pump by tough polythene tubing.

SOLUBLE OIL EMULSIONS

For most work a soluble oil emulsion should be chosen since this will almost always be adequate for general usage and will be preferred by machine operators.

When screwing with a die-head, tapping or reaming, some extra coolant or cutting fluid applied locally may be required. If much work of this nature is contemplated, it may be better to use an emulsion of extreme-pressure soluble oil in the coolant sump. A good quality oil of this type will give results equal to neat cutting oil whilst retaining all the advantages (cleanliness, etc.) of soluble oil.

Good quality soluble oil should be chosen and mixed in accordance with suppliers' recommendations. The following grades have been tested and used in our own works with satisfaction:—

Shell Drommus Oil B—conventional milky soluble oil, mixed with water in ratio 25/30: 1.

Shell Drommus Oil D—translucent soluble oil, mixed with water in ratio 40 : 1.

Shell Drommus Oil F—extreme pressure oil, mixed with water in ratio 10/15 : 1.

SOLUBLE OILS & MACHINE MAINTENANCE

No soluble oil, however good, can completely prevent rust without help from the operator.

The lathe should therefore be cleaned down often and all bright parts kept lubricated with machine oil. The machine should never be left, especially over week-ends or holidays, with wet swarf on bed or slides.

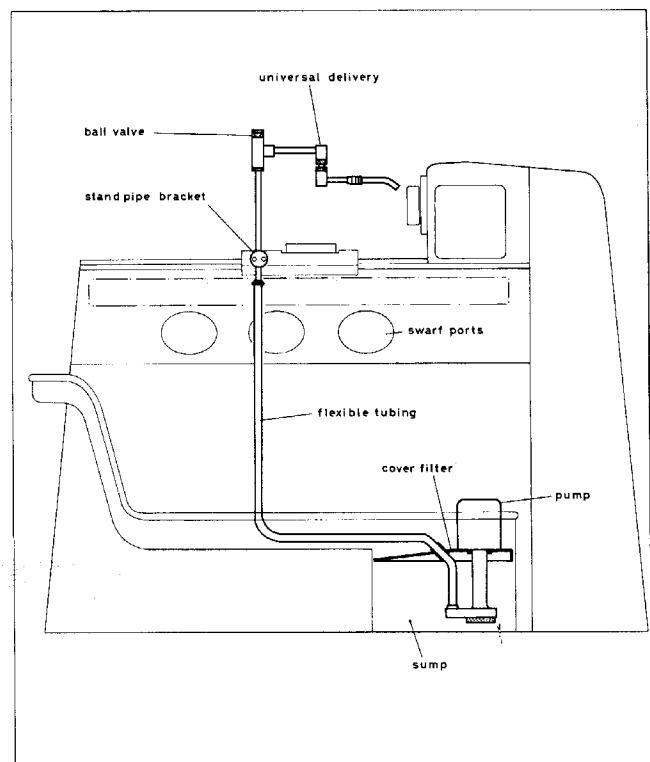

Should the work require that the carriage is locked in position for long periods, it is advisable to spread machine oil or way-lubricant on the bed-ways before-hand, thus ensuring an anti-corrosive film between surfaces.

The sump should be emptied completely, cleaned out and re-filled with fresh-mixed coolant at regular intervals.

These simple precautions will avoid damage and subsequent failure and help ensure long, trouble-free life for all parts.

ALIGNMENT CHECKS

When the machine has been completely installed it is advisable to check the alignment of the headstock and tail stock. All machines are accurately aligned before despatch but transit shocks may necessitate adjustments.

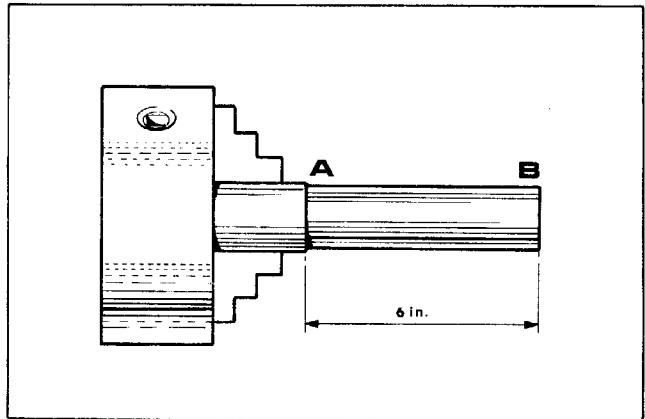

Fig. 15

HEADSTOCK ALIGNMENT

Set a length of mild steel stock about 2 in. dia. in the chuck and take a light cut with a keen tool over a 6 in. length (Fig. 15). Do not support at the free end. Micrometer readings at each end of turned length (A and B) should be the same.

To correct a difference in readings, slacken off headstock hold-down bolts (1) see Fig. 16, and pivot the headstock around dowel (2). As a guide, with a dial indicator set against point B of Fig. 15 it will be necessary to swing the headstock about 2½ times the difference in micrometer readings between A and B.

It is important that after adjustment all hold-down bolts are securely re-tightened.

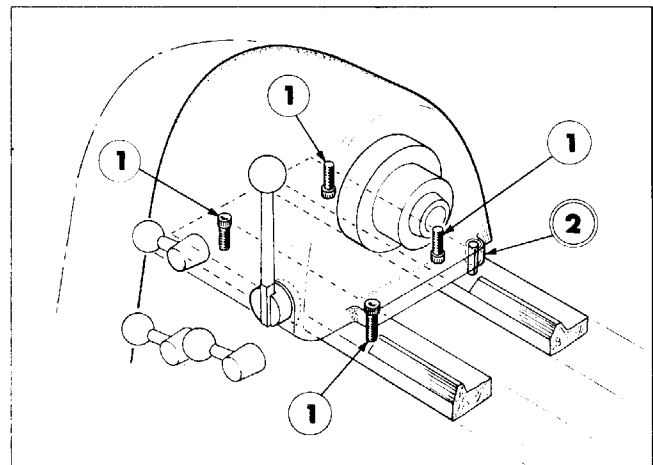

Fig. 16

TAILSTOCK ALIGNMENT

Using a 12 in. ground steel bar between headstock and tailstock centres (Fig. 17) check alignment by fixing a dial test indicator to the topline then traversing the centre-line of the test bar.

To correct any error, release tailstock clamp lever and adjust set-over screws (refer to Fig. 14). Continue checking and correction until alignment is perfect.

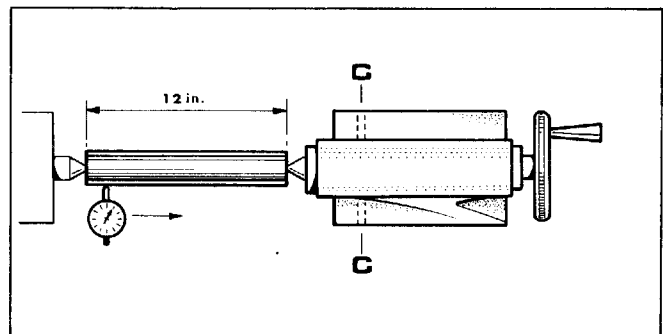

Fig. 17

TRANSMISSION

The single-speed motor (1) Fig. 18 is coupled to a variable-speed unit (2) by a toothed rubber timing belt, the motor being mounted on the underside of the mounting bracket to form a compact drive unit.

From the variable-speed unit, vee-belts transmit drive to a machine-tool clutch (3) on the headstock. Spindle speeds are controlled through gearing from the handwheel (4) on the front of the cabinet base.

Drive from headstock to gearbox is transmitted through a gear train carried on an adjustable swing-frame.

Gears must be thoroughly cleaned before fitting and backlash maintained at .005 in. for correct meshing. Lubricate gears regularly with gear oil. Oil idler gear stud every day.

Access to the drive unit and end-gears is by unlocking the end-guard and swinging it back on a spring stay. After attention or inspection, close and lock the end-guard before starting the lathe.

DRIVING BELTS

Maintain Vee-driving belt tension to $\frac{3}{4}$ in. deflection at a point midway between pulleys, using finger pressure only.

To alter tension, adjust the three jack-bolts at the base of the mounting bracket. Ensure that adjustment does not cause binding of the speed selector against the cabinet base.

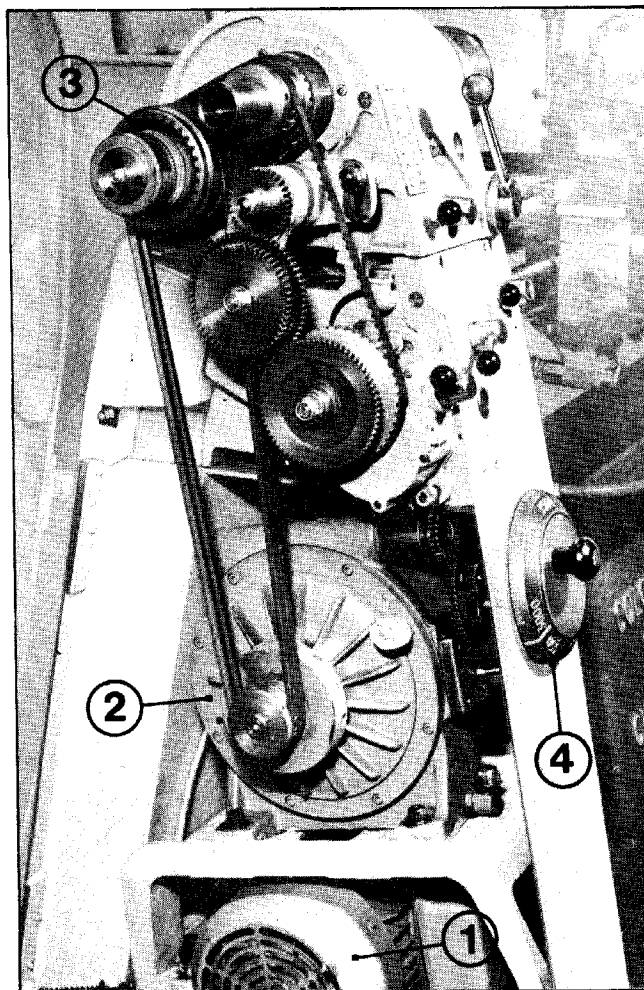

Fig. 18

SHEAR PIN

To protect the leadscrew against overload in the low speed range a shear pin is incorporated in the driving gear sleeve and shaft; immediately below the spindle, Fig. 19.

Fig. 19

To replace a broken pin:—

- (a) Remove the driving gear and shearpin sleeve. Tap out the headed portion of pin.
- (b) Rotate the driving shaft until the remaining portion of pin is in line with the slot in the shaft housing. Tap the pin into the slot.
- (c) Re-assemble the shear pin sleeve and fit new pin.
- (d) Complete gear re-assembly.

In case of difficulty in obtaining new shear pins, they may be manufactured from $\frac{1}{8}$ in. dia. Mild Steel rod to B.S. EN1A (shear strength 20 tons per sq. in.). No other material should be used.

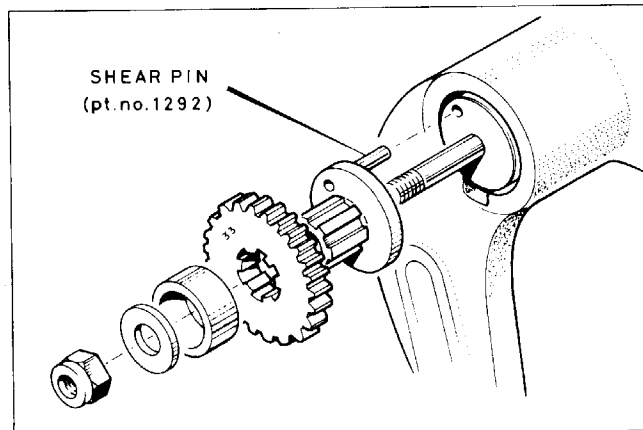

LUBRICATION

Accuracy and trouble-free life of the lathe depend to great extent on correct lubrication.

All oiling points (see Lubrication Diagram) and the oil levels in headstock, gearbox, variator and apron should be regularly checked. When checking headstock and gearbox, stop the machine and allow oil to settle so that a true reading can be obtained. Overfilling will result in risk of excessive heat and loss of oil through leakage.

INITIAL RUN

After the lathe has been in operation for an initial period of 160 hours or four weeks (whichever is shorter) the headstock, gearbox and variator should be drained, flushed with clean flushing oil, then refilled to correct levels with fresh oil of appropriate grade (see "lube grades"). This procedure should be repeated every 500 running hours or every three months.

VARIATOR

Top up weekly to level on the column indicator at base of the variator. Use only correct grade of oil: wrong grades can cause serious loss of efficiency or permanent damage. Capacity is one pint. Leave the unit at rest for 30 minutes after use before checking oil level.

CLUTCH

The matrix clutch bearing should be lubricated every three months with Shell Alvania 3 grease, a grease nipple is provided at top of the bearing housing, against the headstock end-wall.

DRIVE MOTOR

Shaft bearings at front and rear are pre-packed with Shell Alvania Epro grease, with grease nipples provided at each point. Renew lubricant every twelve months. Avoid over-lubrication.

LUBE GRADES

When the machine is despatched from the factory, the headstock, gearbox, variator and apron are filled with the following grades of lubricant:—

Headstock:	Shell Tellus Oil 15.
Gearbox:	Shell Tellus Oil 33.
Variator:	Shell Tellus Oil 15.
Apron:	Shell Tonna Oil 33.

These oils, each with matched and recommended characteristics, may be obtained from Shell Oil depots throughout the world. In case of difficulty in supply these particular grades are summarised by physical properties as follows:—

	Tellus 15	Tellus 33	Tonna 33
Spec. grav at 60°F	0.845	0.876	0.881
Flash point closed	300°F	410°F	430°F
Pour point	-20°F	-20°F	-15°F
Viscosity Redwood			
No. 1 ...			
70°F	100 secs.	750 secs.	750 secs.
140°F	42 secs.	112 secs.	105 secs.
200°F	—	52 secs.	50 secs.

USE OF INCORRECT GRADES OF OIL IS LIABLE TO CAUSE OVERHEATING AND POSSIBLE DAMAGE.

SADDLE LUBRICATION

A one-shot type manual pump system for lubrication of carriage slideways is incorporated to assure adequate and periodic oiling with the correct grade oil.

On the front of the saddle casting is a thumb-button pump (see Fig. 12) which draws oil from a separate reservoir inside the apron. Operate the pump every hour, pressing and releasing the spring-loaded button until oil issues from the tell-tale hole at right-hand side of the saddle casting.

Be sure to top up the apron reservoir every few days to ensure trouble-free slide movement.

GENERAL LUBRICATION

In addition to pump-fed lubrication, oiler points are provided on saddle crossslide and topslide for weekly attention. Use a standard pump-type can filled with light machine oil or way lubricant.

On the tailstock, oiler points are provided for weekly attention.

It is recommended that after every work period the slideways, leadscrew and feedshaft are cleaned off and lightly oiled.

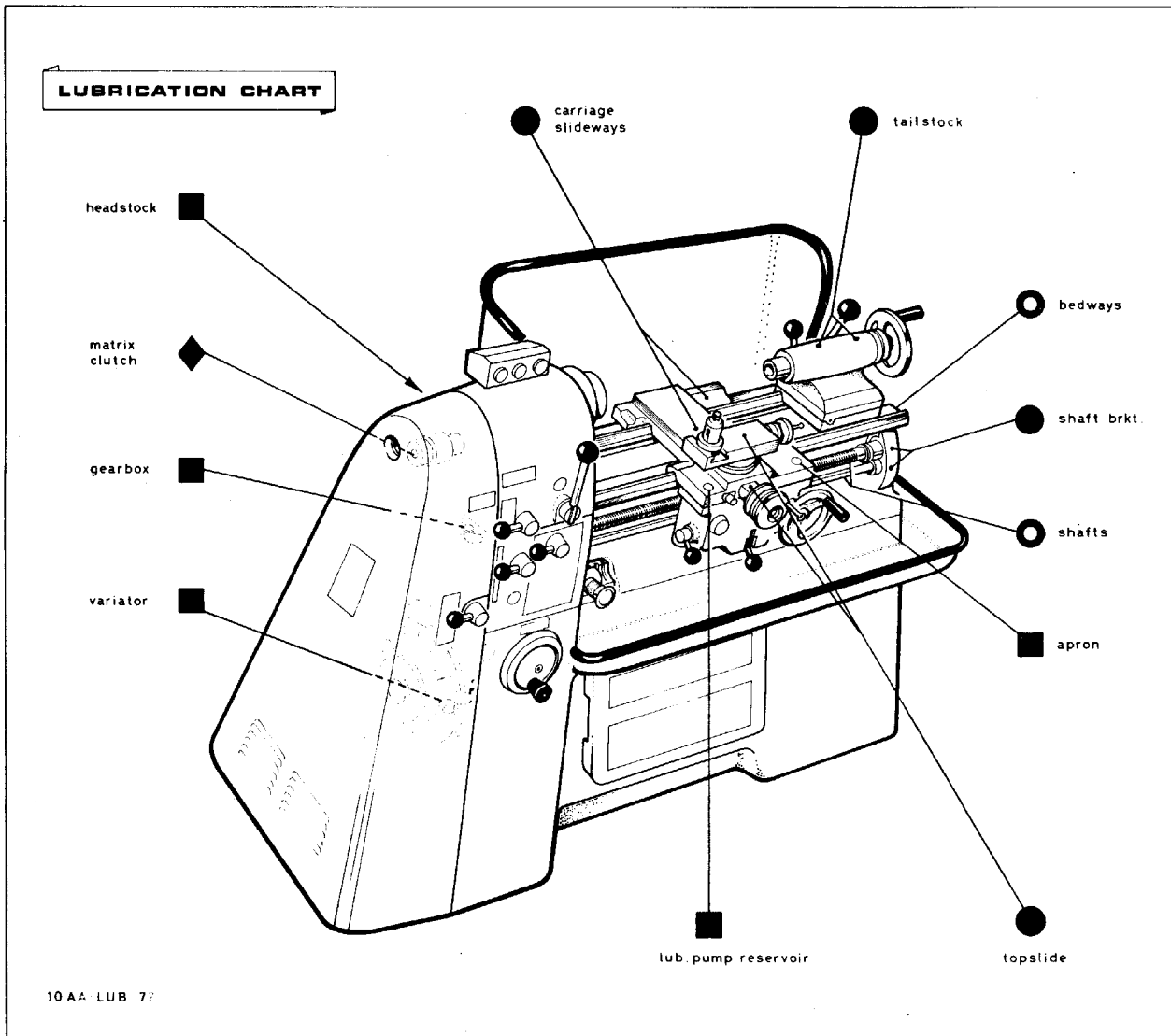

10-AA Variable speed Lathe

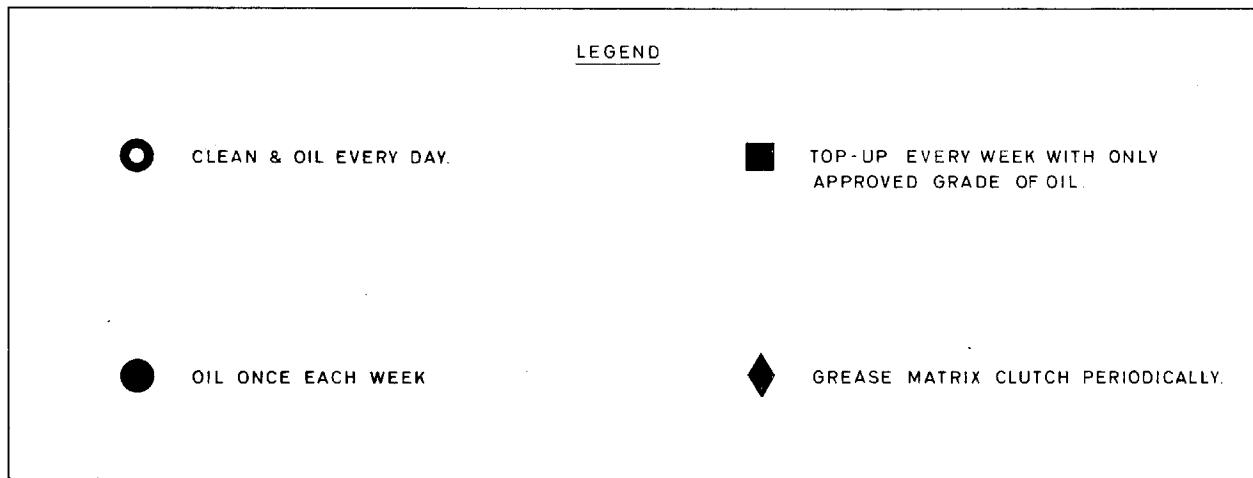

10-AA LATHE
SCHEMATIC
WIRING
DIAGRAM



IMPORTANT --
DISCONNECT INPUT
BEFORE REPAIRING
OR REPLACING ANY
COMPONENT.

STATE SUPPLY VOLT -
AGE ON ALL ENQUIRIES
OR PARTS ORDERS.

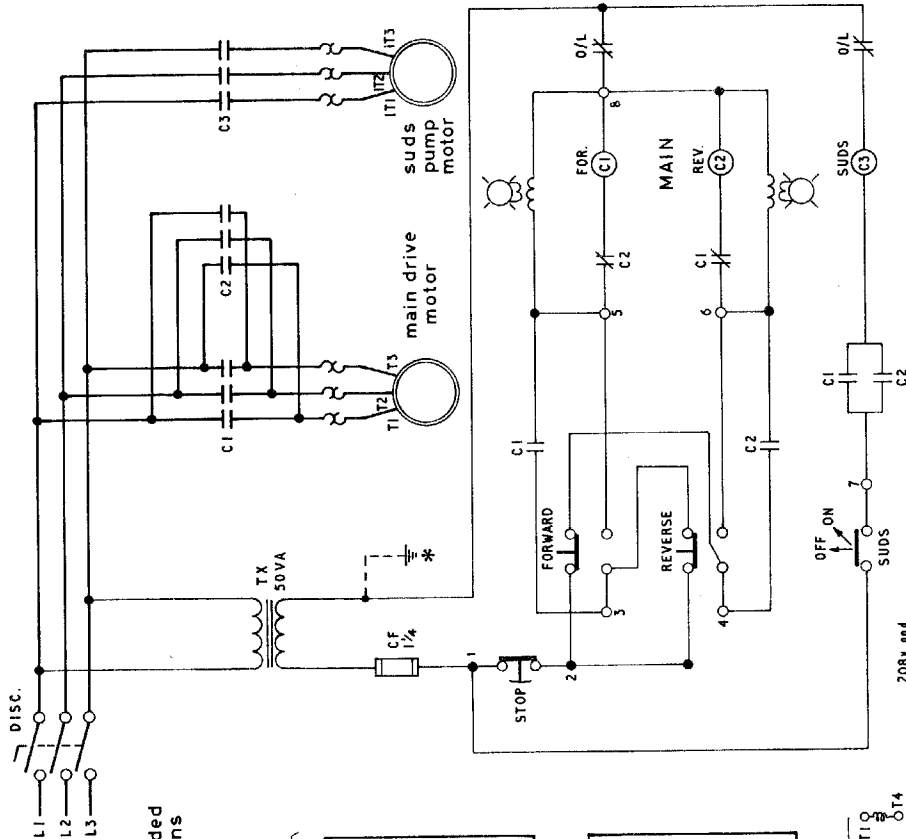
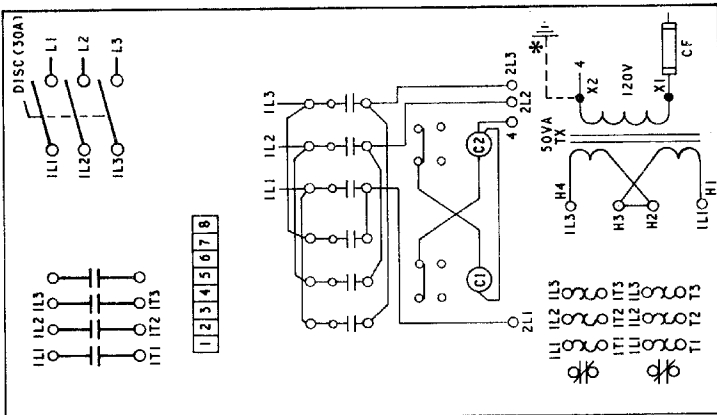

* Note :- to be grounded
by user if conditions
permit.

**TRANSFORMER
ALTERNATIVES**

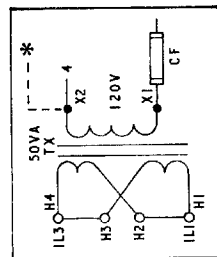
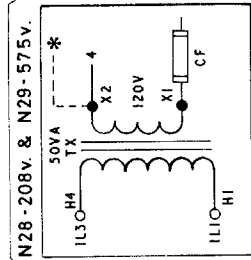

460 V.

EXTERNAL DEVICES

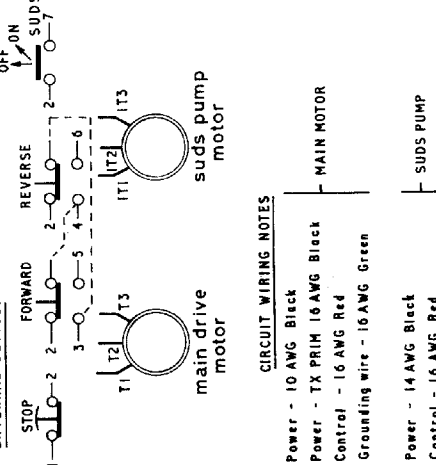

CIRCUIT WIRING NOTES

- Power - 10 AWG Black
- Power - TX PRIM 16 AWG Black
- Control - 16 AWG Red
- Grounding wire - 16 AWG Green
- Power - 14 AWG Black
- Control - 16 AWG Red
- SUDS PUMP
- MAIN MOTOR

all wires UL approved

COMPONENTS LIST

Ident.	Specification
DISC	BUL 1494 RN30 - 30A.
C1, C2	BUL 705 A0D 23
TX	BUL 1497-N27 230/460V. or BUL 1497-N28 208V. or BUL 1497-N29 575V.
C3	BUL 702-T0D93
CF	BUL 1492 CE6
CF	Fusestron FNM 1-4
O/L	BUL 815 BOV16
O/L	BUL 1492 CA2
STOP	BUL 800T D6 D2
FORWARD	BUL 800T PB-16A
REVERSE	BUL 800T PB-16A
OFF/ON	BUL 800T H2 D1

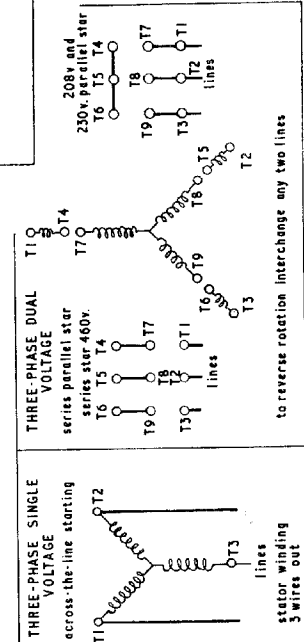

HEATERS for main start overload :-
208v N32 230v N30 460v N22 575v N21
MAIN MOTOR - UL APPROVED - 3H.P. - 3PHASE - 60 CYCLES - 1800 R.P.M.
FRAME SIZE 182T / DC 1512 BBA - 208 or 230/460 or 575 volts.

VARIABLE-SPEED UNIT SERVICING

MECHANICAL PRINCIPLES

From the diagrams it will be apparent that when ball spindles are parallel to drive shafts (Fig. 1) the ratio input/output is 1:1, as the effective diameters on drive balls at point of contact with drive cones are equal. When ball spindles are tilted, by movement of the iris-plate, relative diameters on drive balls at points of contact with drive cones become changed. One direction of tilt (Fig. 2) reduces output speed whilst reverse direction of tilt (Fig. 3) increases output speed.

2. Test for rotational backlash between input and output shafts by rotating them by hand in opposite directions. Perceptible backlash (more than two degrees) must be eliminated by adjusting the cap immediately behind the output pulley.
3. To adjust, slacken the Allen screw located in the rim of the cap and turn clockwise by tommy-bar inserted in one of the radial holes. Retighten the securing screw when adjustment is completed. Alternative screw positions are provided in the cap for ease of access.
4. Refill variator to correct oil level.
5. After a running-in period, recheck adjustment and the tightness of end-cover fixing screws. Should the variator tend to lose speed under load, further adjustment should be made until slipping is eliminated.

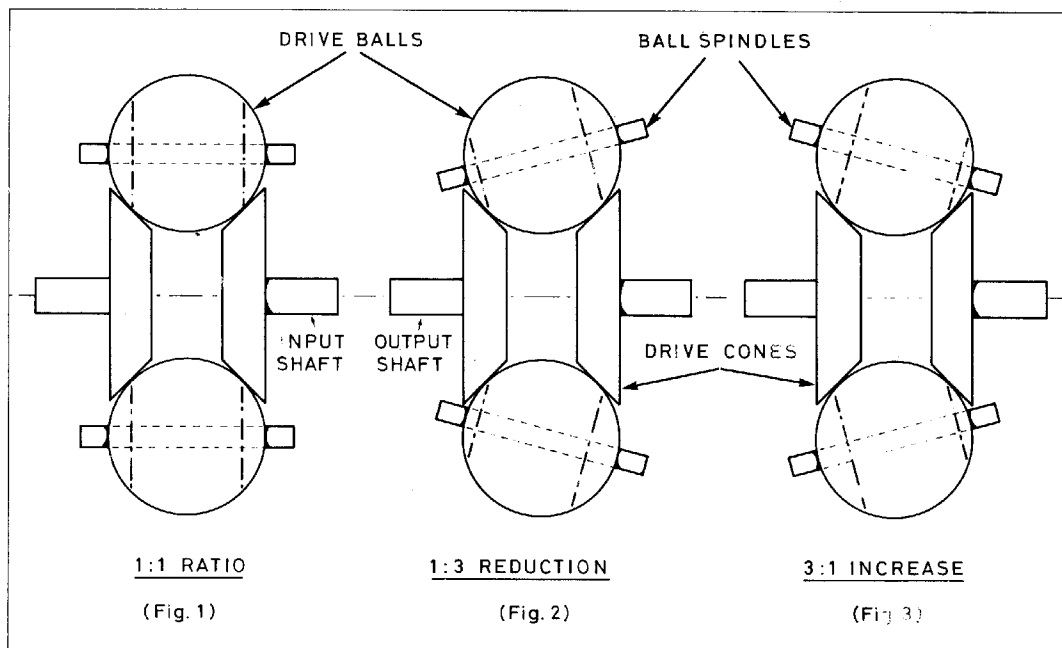

PRESSURE DEVICE (Fig. 4)

A hard steel disc (N) is located on splined drive-shaft (O). The drive cone (P) is free to rotate on the shaft and both drive cone and splined disc have a series of vee-shaped ramps in their faces. Between these faces is a cage holding rollers (R), one of which is located between each pair of ramps; in addition, a pair of conical spring washers (Q) is fitted in recesses in drive cones and splined discs.

Under "no-load" conditions, the roller is located at bottom of the vee-ramps and no axial pressure is being exerted other than the initial pre-load by the conical spring washers (Q) which produces the necessary starting traction.

As torque is applied during "on-load", the rollers ride the ramps and produce a wedging action to give a resulting axial pressure between drive balls and drive cones.

ADJUSTMENT

1. Rotate output shaft by hand and carefully move speed control to highest output speed position.

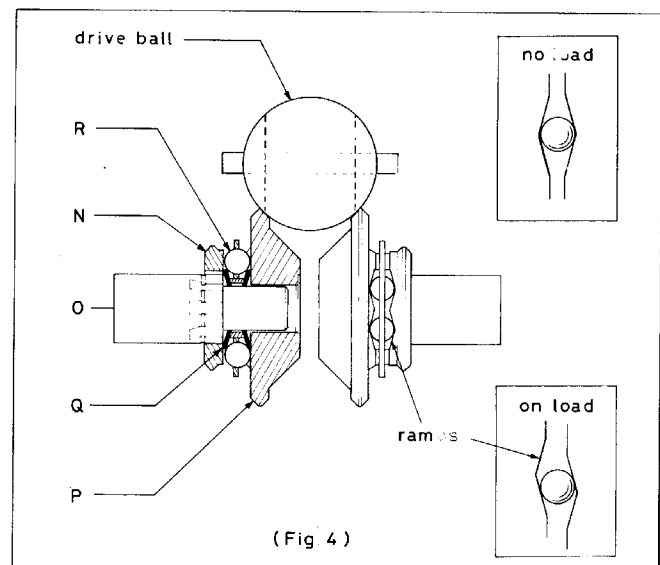

ACCESSORIES

A comprehensive range of attachments and accessories is available for this machine, specifically designed and engineered for rugged reliability, to make your lathe even more versatile.

A brief list is given below with Code Numbers for ordering. More detailed information is given on certain items in subsequent pages.

Hydraulic copying unit	167
Collet chuck 1½in capacity	152
Collets (round bore)	153
Chuck, 3-jaw 125mm	101
Chuck, 4-jaw 205mm	102
Chuck/chip guard	164
Rear toolpost (quick-change)	146
Steady rest, 3-point	109
Low volt lighting	110
Rotating centre — 3 M.T.	117
Work driving dogs (Set of 7)	120
Drill chuck — 3 M.T.	122
Feed stops, cross-feed	124
Feed stops, long-feed	125
Backplate	127
Taper-turning attachment	132
Spring-loaded safety chuck key	106
Multi-position longitudinal bedstop	183
Trav-a-dial positioning accessory	188
Lever-operated tailstock quill	185
Centring centre — 3 M.T.	116
Magnetic-base chip guard	165
Change-wheels for special threads	119

All accessories listed can be fitted to your lathe after it has left the plant and do not in any way detract from normal usage.

QUICK CHANGE TOOLPOST

This type of toolpost may be fitted to existing standard slotted topslides without alteration. It enables any number of toolholders to be used and any lathe operation to be carried out. Designed to cut down time on repetition work, the Quick Change Toolpost is outstanding in its versatility and ease of use. It consists of a basic clamping head to which a variety of toolholders may be fitted.

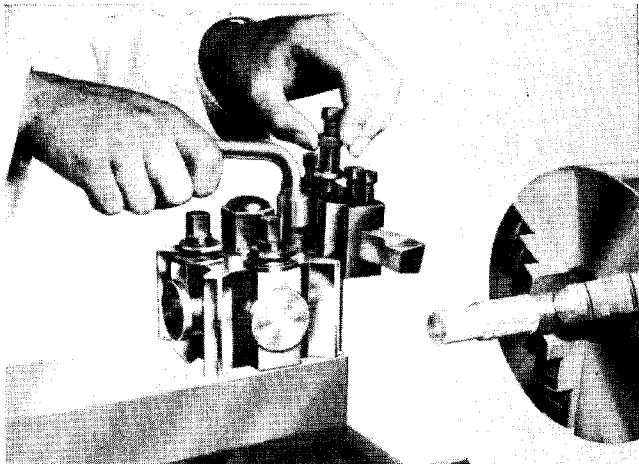

Three types of toolholder are available.

The standard toolholder will accommodate all normal types of tool up to a maximum size of $\frac{3}{4}$ in x $\frac{1}{2}$ in (19mm x 12.5mm). The vee toolholder will accommodate boring tools with parallel shanks up to $\frac{1}{2}$ in. (16mm) diameter. A morse taper holder is also available suitable for all tools having a No. 1 M.T. shank.

Each toolholder has a vertical adjusting screw and when a tool in its holder has been set to centre height it may be removed and replaced any number of times in the sure knowledge that the tool will be at exact centre height each time it is returned to the clamping head.

The toolholders listed above are included with the toolpost as standard equipment.

An additional range of holders are also available. Brief details are as follows:

- Oversize morse taper holder No. 83152
- Plain bore holder No. 83149
- Knurling toolholder No. 83146
- Throw away tip toolholder 0° approach No. 83001
- Throw away tip toolholder 15° approach No. 83004
- Throw away tip toolholder 45° approach No. 83007
- Throw away tip toolholder 90° approach No. 83010

FEED STOPS

To provide an accurate and reliable means of repeating shoulder lengths single type or five-position type feed stops are available. A five-position stop can also be supplied for repeating diameters. With these units the saddle of cross slide can be stopped in any desired position, the feed mechanism in the apron disengaging immediately contact is made.

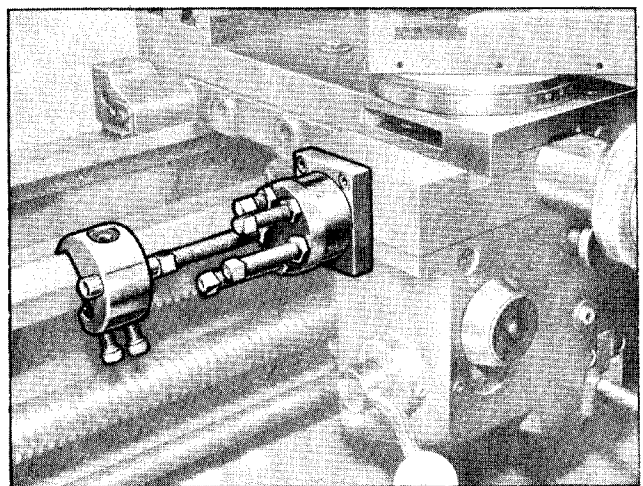

Stops on lathe bed (lengths)

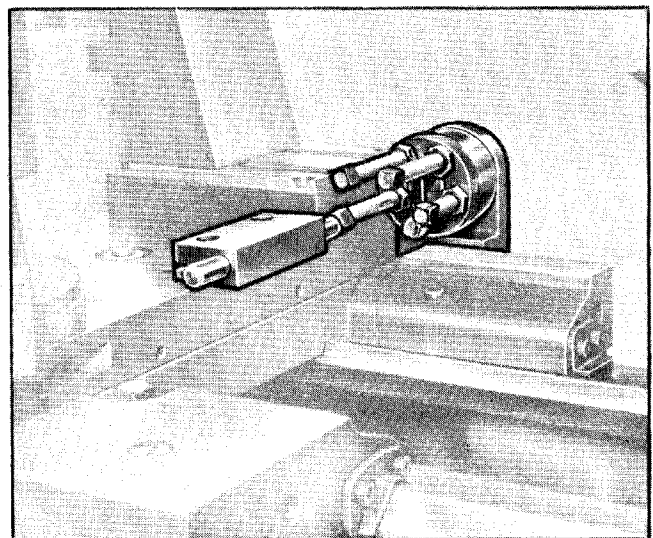

Stops on cross-slide (diameters)

TELESCOPIC TAPER ATTACHMENT

This attachment can be used for producing tapers up to 10° in either direction.

It can be mounted directly onto the rear of the saddle without any modification other than the fitting of a new saddle screw and nut which is supplied with the unit.

The swivel is graduated in degrees of arc and great sensitivity of control is obtained when setting a taper by the use of the micro adjustment screw.

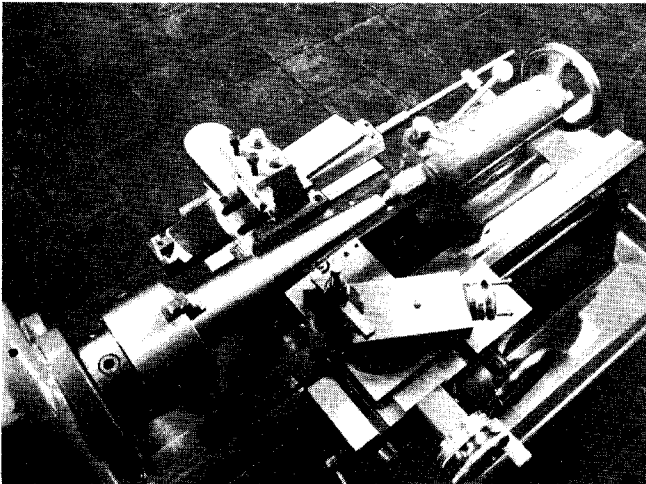

The cross slide handwheel is always used to control the tool and the base slide can be adjusted along the bed so that the taper may be cut in any position. The attachment will deal with a length of 12in of taper at any one setting.

After attaching to the machine, all that is required to prepare the taper turner for use is the clamping of the connecting rod in the anchor bracket by means of the knurled thumb-screw.

The fitting of this attachment in no way detracts from the use of the machine as a normal centre lathe. Change over can be simply accomplished by loosening the connecting rod clamping screw and traversing the saddle towards the headstock to disengage the connecting rod from the clamp. Then remove the anchor bracket from the bed so that there is no obstruction to foul the connecting rod. By replacing the bracket and engaging the connecting rod the taper turner is rapidly reset for use.

Great care should be taken when readjusting or altering the fit of the base slide in the taper turner bracket, as any slackness will result in incorrect tapers.

To fit the taper attachment

1. The saddle and cross slide are ready drilled to receive the attachment, the necessary holes being drilled and tapped during manufacture.
2. Clean down the rear end of the saddle to receive the taper turner bracket.

3. Release the locknut in the centre of the cross slide handwheel.
4. Slide the cross slide to the rear of the saddle.
5. Remove the saddle screw nut fixing bolt and withdraw the screw and nut from the rear.
6. Insert the taper turner saddle screw and nut and secure the nut with the fixing bolt.
7. Pull the cross slide forward and engage the saddle screw in the handwheel pinion. (Note: The lock nut from the original saddle screw is not replaced, but should be retained in case it is needed when refitting the original screw.)
8. The slide block assembly can now be fitted to the thrust block on the rear of the saddle screw assembly. Engage the slides in the bracket and the slide block assembly on the slides. This will enable the bracket to be bolted to the rear of the saddle using the pre-tapped holes provided.
9. Finally, bolt the bottom slide extension piece to the rear of the bottom slide. Fit the connecting rod to the taper turner slide and the connecting rod clamp to the machined face on the back of the bed.

STEADY REST

Of extremely rigid design and having a maximum capacity of 4in bar diameter, this attachment is rapidly clamped on to the bed by a plate and bolt and easily removed when not required.

The top section is locked by a knurled screw and the adjustable fingers are fitted with replaceable sintered bronze press fit inserts.

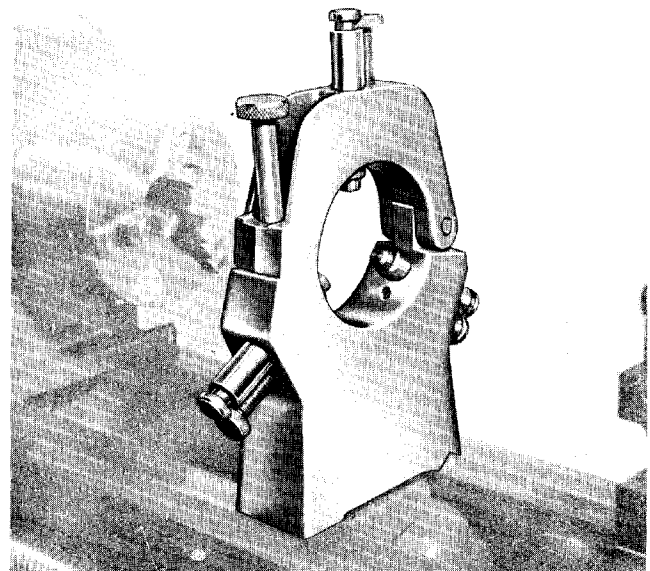

HYDRAULIC PROFILING UNIT

Designed for faster and more accurate profiling, the standard equipment comprises a profile slide assembly, a rear beam assembly for round or flat masters, a free standing hydraulic power unit and a set of connecting hoses housed in a single flexible armoured conduit.

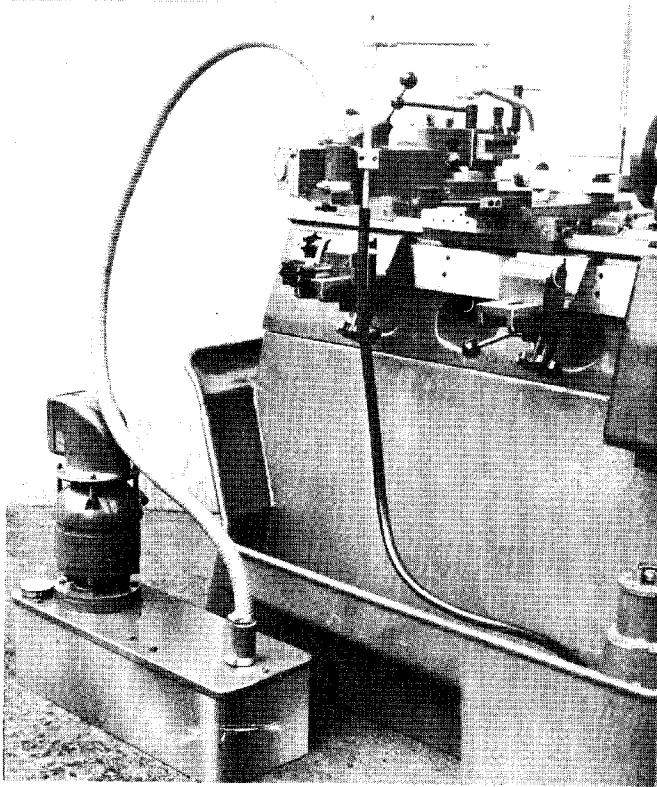

Profile Slide Assembly

Mounted on the cross slide of the lathe, this is an integral unit consisting of the operating cylinder, cartridge type servo valve, stylus lever mechanism and a swivelling Multi-type Toolpost complete with one turning toolholder.

The cylinder has a 3in (76mm) stroke and a maximum approach/retraction speed of 110ins (279cm) per minute. The low stylus pressure of 6 oz. (170 g) allows soft masters to be used if necessary, and the in-feed rate is lever controlled.

A swivelling Multi-type Toolpost allows tooling to be pre-set and enables tool changes to be made without re-setting the slide assembly. Sufficient height adjustment is provided to allow the tool to be set for forward or reverse cutting.

The assembly can be set at five alternative angles to the axis of the machine — either 90°, 60°, 30°, 0° or -30°, depending on the work to be produced and a copying accuracy of $\pm .0005$ ins. can be achieved. The change in copy diameter at 90° is 5½in and at 60° 5in.

The Rear Beam Assembly

The beam fixes directly to the rear face of the lathe bed and provides a rigid datum surface for carrying the master parallel to the axis of the machine.

Two beam brackets slide on the rear beam and provide a locating surface for the tailstocks which accommodate round masters or flat templates. The tailstocks are adjustable for the micrometer setting of the master or template.

Hydraulic Power Unit

A free standing unit, designed to fit neatly at the rear of the lathe, has a ½ H.P. pump producing a working pressure of 300 lbs/sq. in. A pressure gauge is fitted and independent switch gear is also incorporated.

The pump and oil filter can be removed as an assembly for inspection.

Turret Stop

An indexing turret stop is available as an optional extra to enable progressive in-feed to be applied between roughing cuts. Six stops provide for five roughing cuts and one finishing cut to be pre-set. Progressive settings of the turret stop enable roughing cuts to be taken at uniform depth. The final cut follows the full form of the copy master.

Facing Beam

A facing beam is also available as an optional extra. Designed for flat templates, it is secured to the saddle of the machine and incorporates micrometer lateral adjustment.

REAR TOOLPOST

As an aid to production, a rear toolpost is available for fitting direct to the cross slide, which is drilled and tapped ready to receive it.

Two tool positions are provided so that the tool may be fitted in the conventional manner or in the inverted position.

Using this toolpost (with the tool fitted in the conventional manner) left-hand threads can be very easily cut.

Supplied complete with all the necessary fixing screws, the only fitting required is the physical bolting of the base pad to the cross slide. Tee slots are provided in the base pad so that the toolpost may be adjusted in position on the base. Maximum tool depth that can be accommodated in either position is ¾in.

The standard Allen keys and spanners supplied with the machine will fit all the nuts and screws in this assembly.

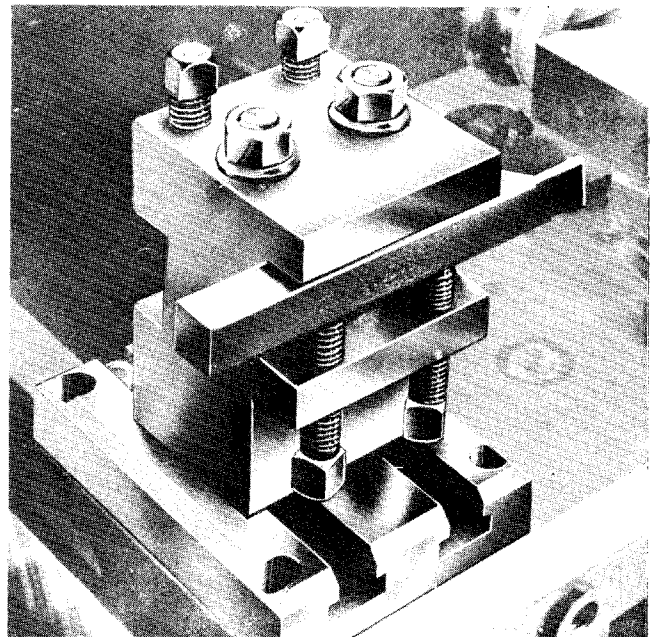

CAPSTAN ATTACHMENT

The five station, manually operated, inclined head capstan attachment is built on a base plate which utilises the existing tailstock ways on the bed and requires no fitting prior to use.

Having a maximum working stroke of $4\frac{1}{2}$ in, the length of travel can be adjusted for each station by setting the stop screws and the turret slide may be locked in any position by a lever situated at the rear of the attachment. Standard single spindle auto toolholders with $\frac{3}{4}$ in shanks (or 20mm shanks if the attachment is supplied with metric bores) are accommodated in the turret, which is positioned and locked after each indexing to an accuracy of 0.0002in (0.005mm) three inches (76mm) from the turret face.

Whilst indexing is normally achieved by returning the slide fully to the right by the handwheel the turret can be rotated by hand if required.

NOTE—

Tooling should be obtained through your usual supplier

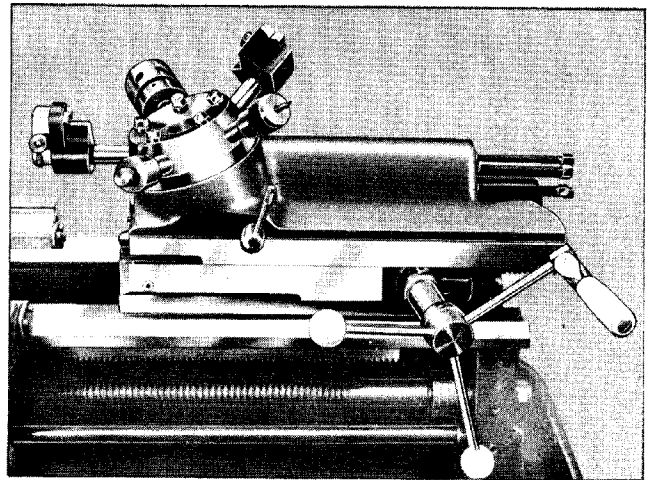

HARRISON Model 10-AA

PARTS SECTION

IMPORTANT WHEN ORDERING—

1. Quote component Order Number and description against each parts illustration for all component parts required.
2. Some parts are standard items which can generally be purchased locally; e.g. nuts, bolts, screws, washers. In such instances, the component Order Number

and description is followed by a code reference e.g. (47-231) which can be referred to Appendix 1 to furnish a full specification.

3. Always quote the lathe Serial Number in all parts-orders or technical enquiries. This number is on a red disc on all major lathe components.

REM SALES INCORPORATED
HARTFORD CONNECTICUT 06107

HEADSTOCK CASTING & LEVERS

FROM SER. No. 5900
TO SER. No.

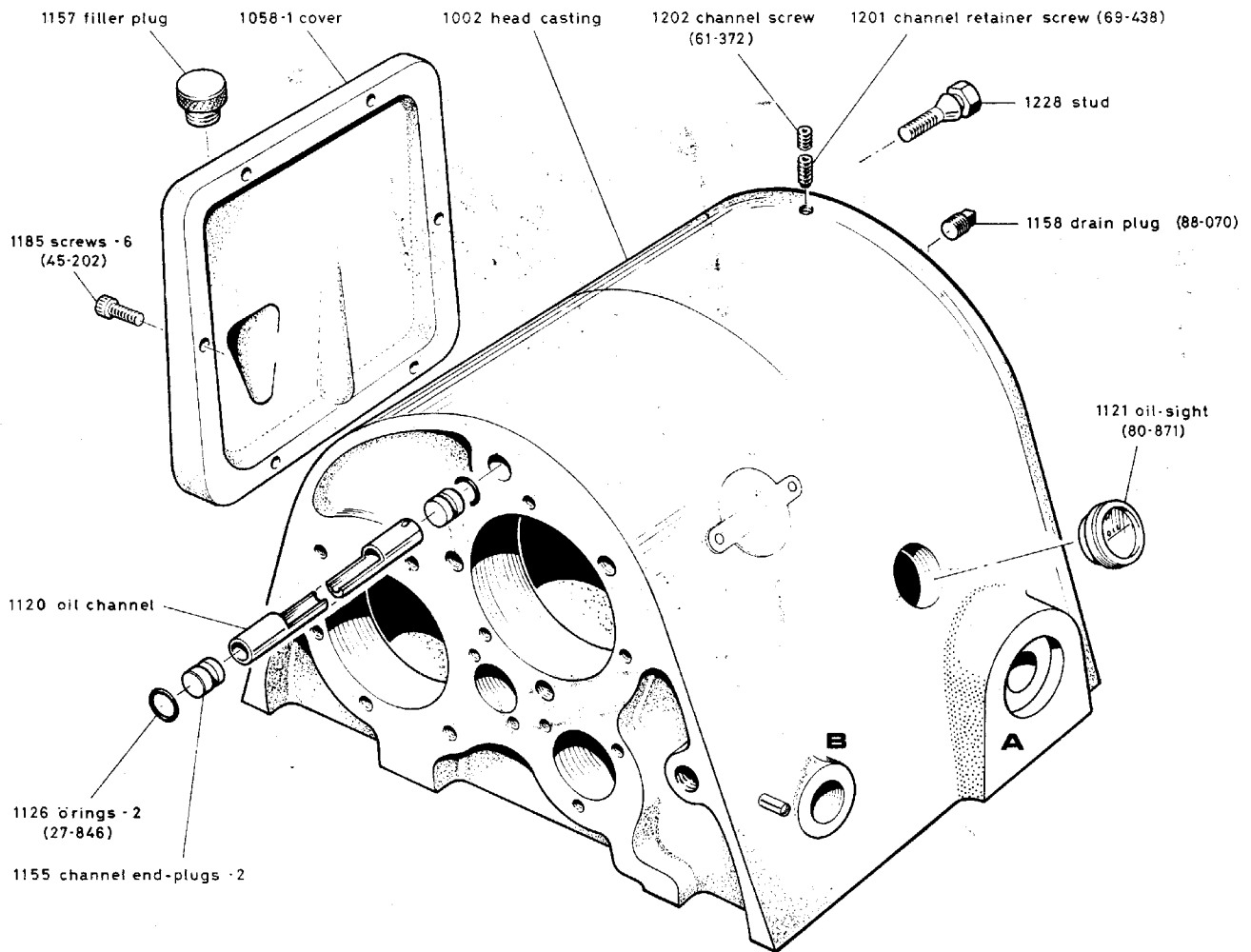

HEADSTOCK GEARS & SHAFTS

FROM SER.No.3311
TO SER.No.

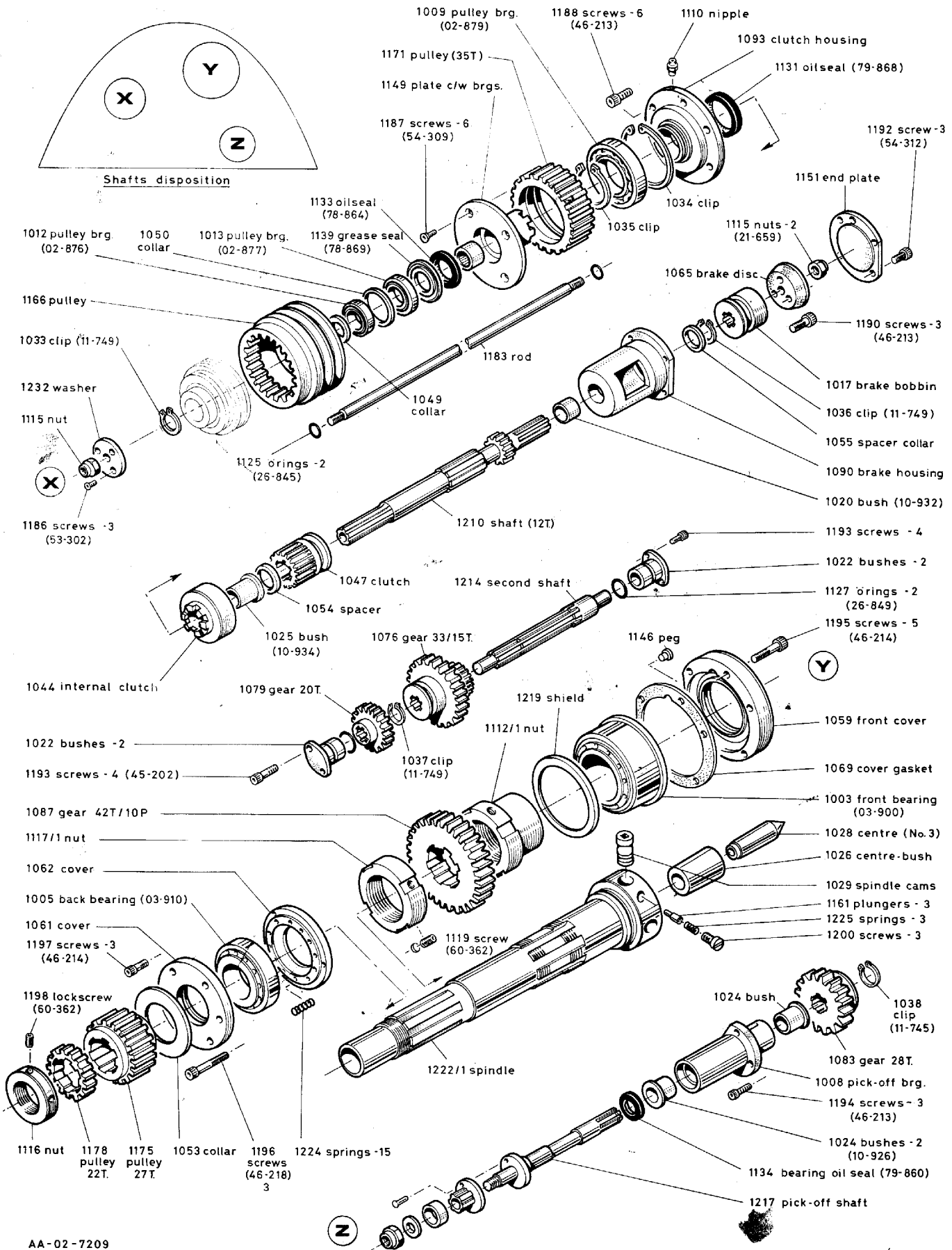

AA-02-7209

MATRIX CLUTCH

FROM SER. No. 2695
TO SER. No.

1264 CLUTCH UNIT COMPLETE - Type ZC

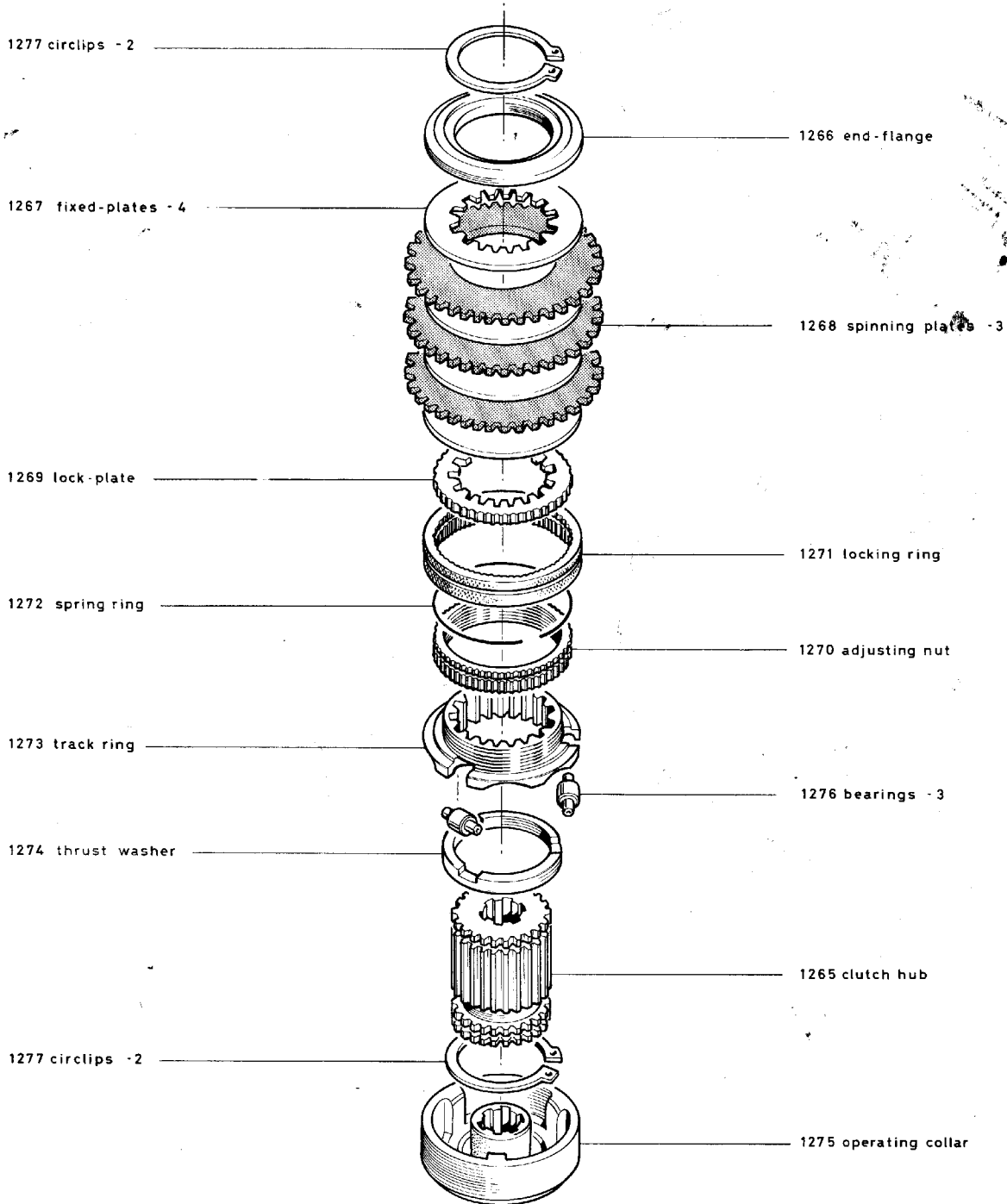

SWING FRAME

FROM SER No. 1000
TO SER No.

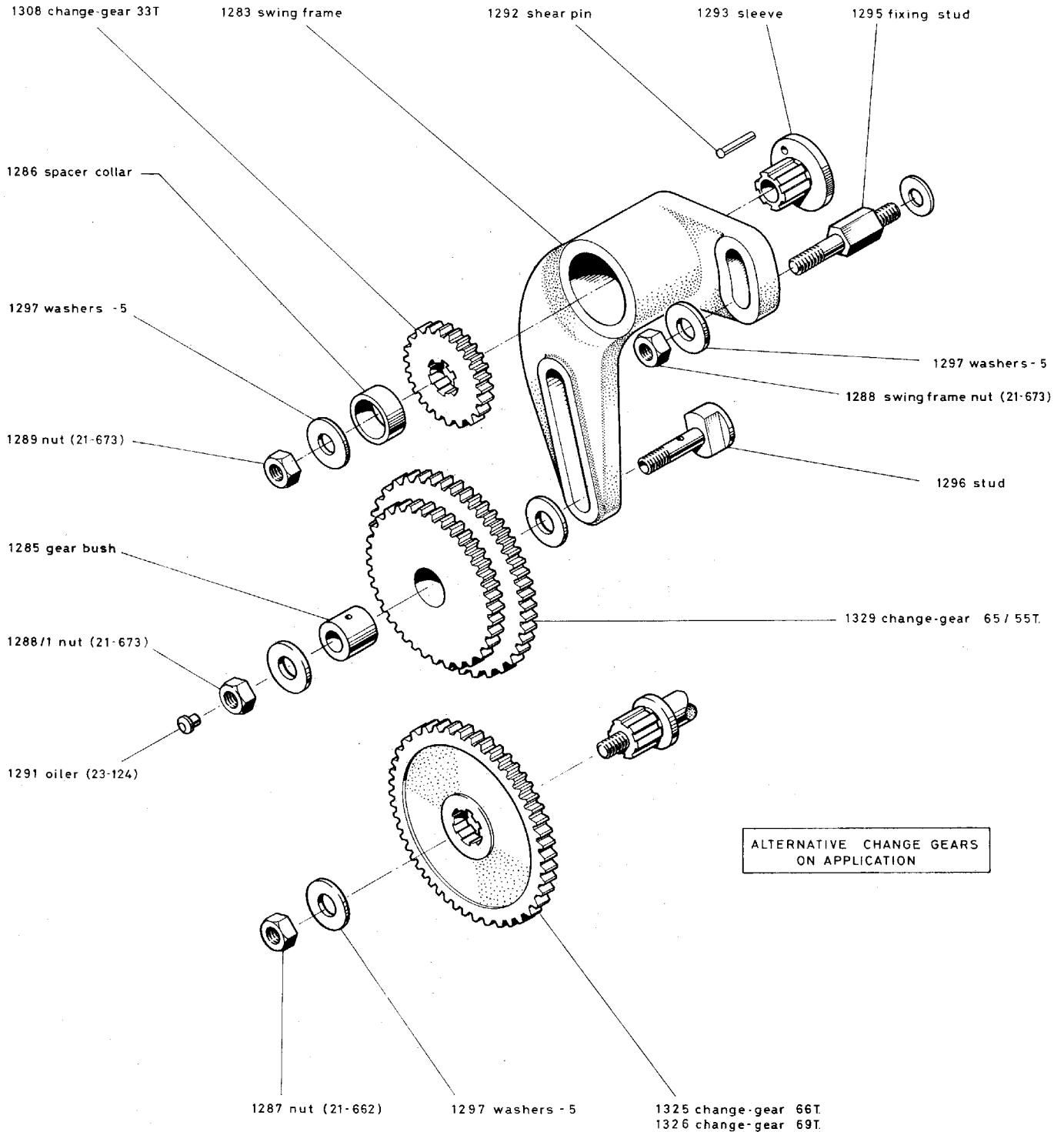

GEARBOX GEARS & SHAFTS

FROM SER.No. 2869
TO SER.No.

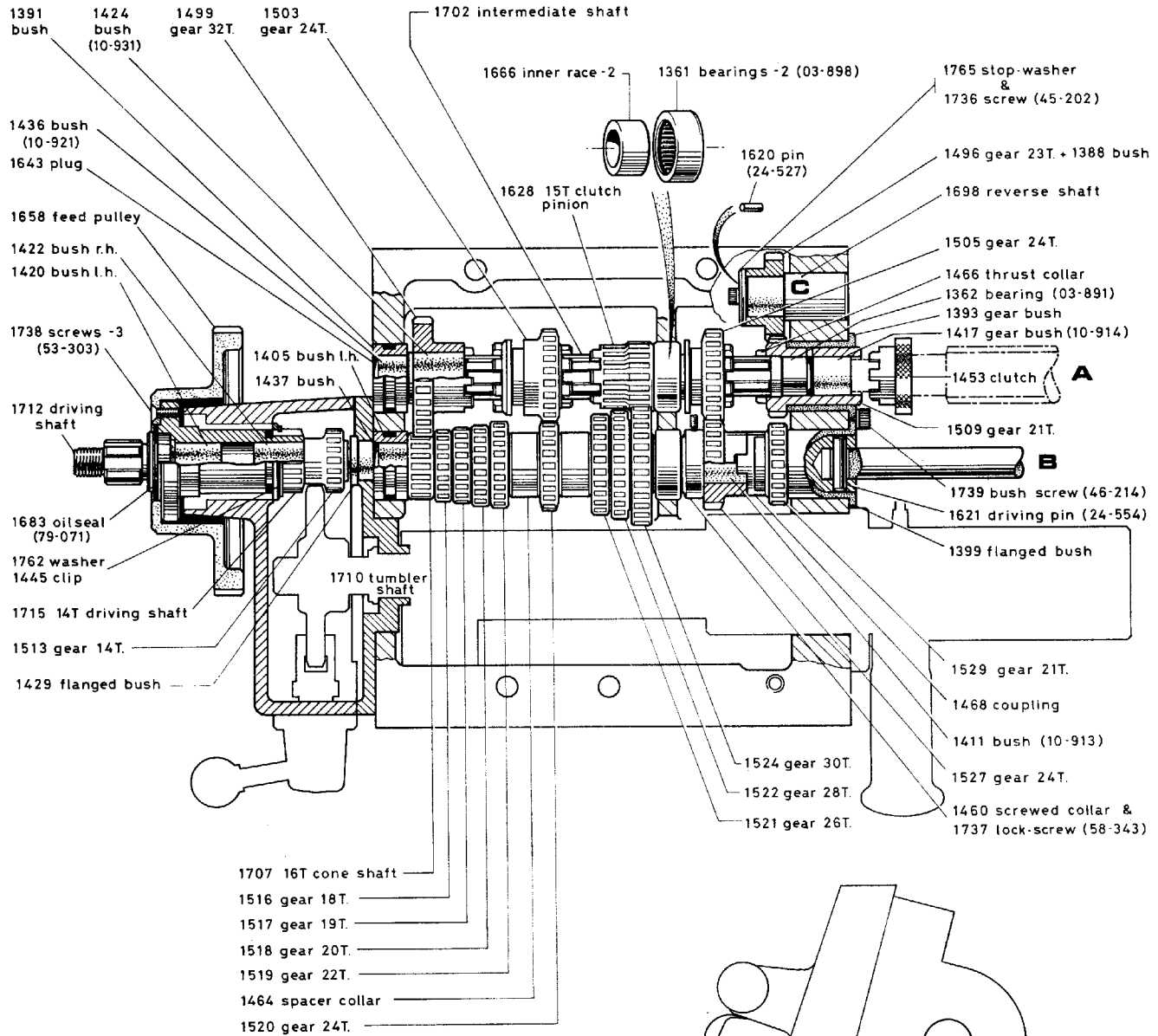

for details of Tumbler Gear -
see page 6.

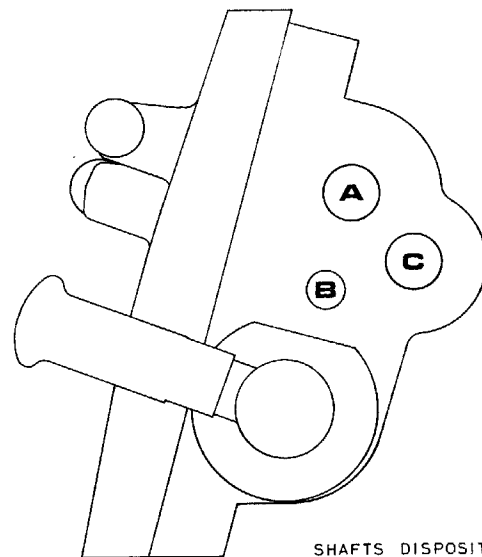

SHAFTS DISPOSITION

GEARBOX CASTING & LEVERS

FROM SER. No. 3022
TO SER. No.

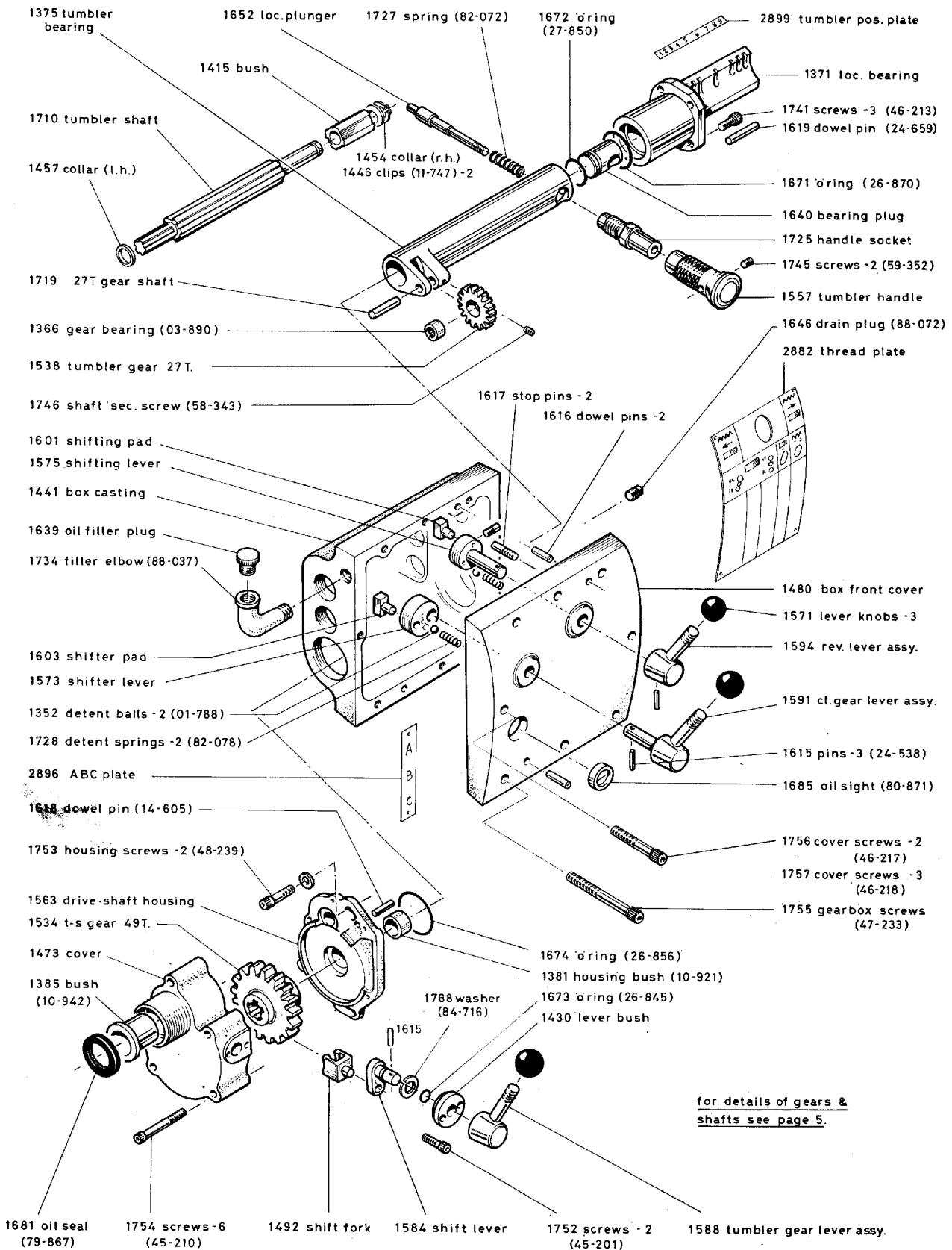

for details of gears & shafts see page 5.

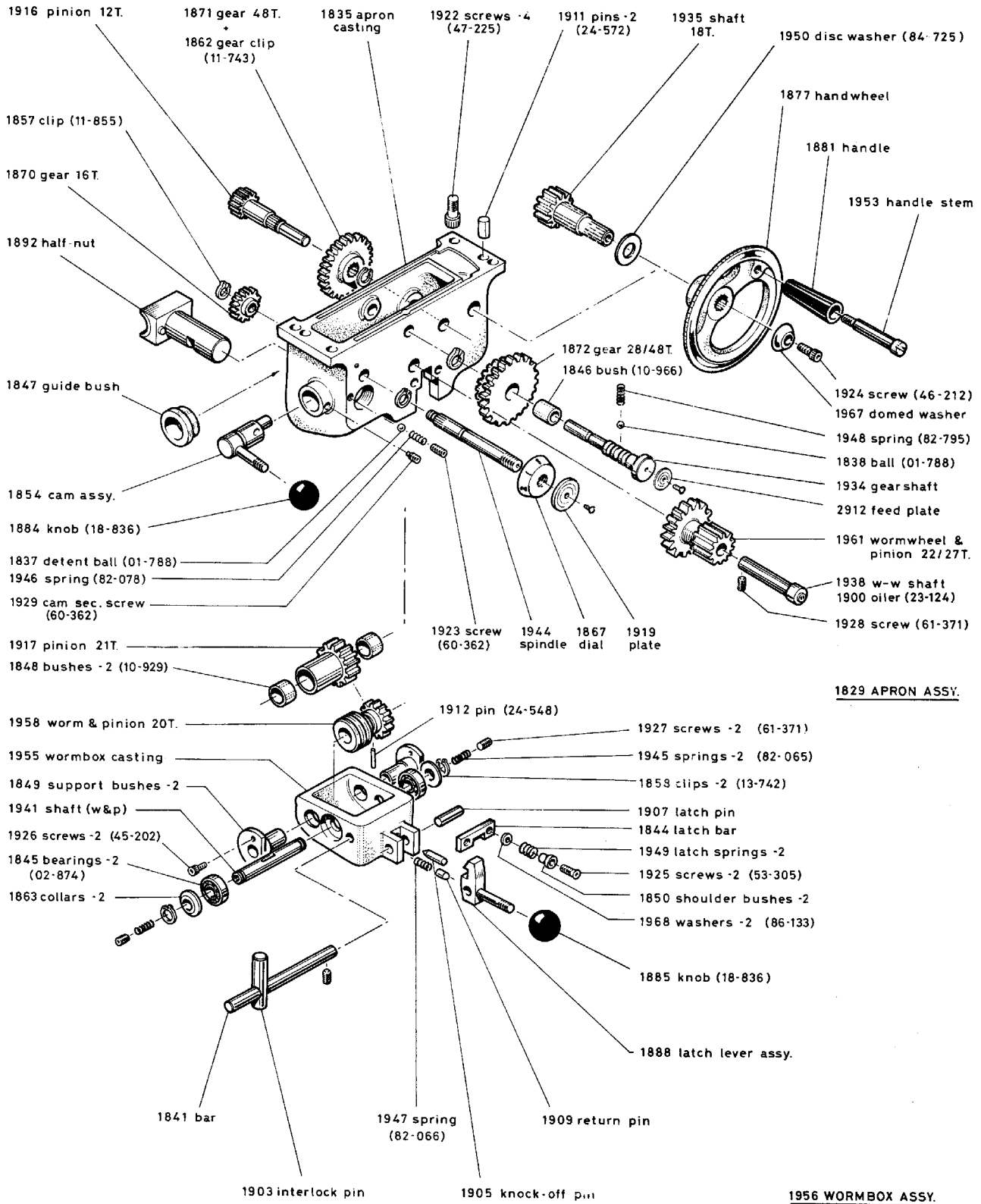

SADDLE & SLIDES

FROM SER.No.4635
TO SER.No.

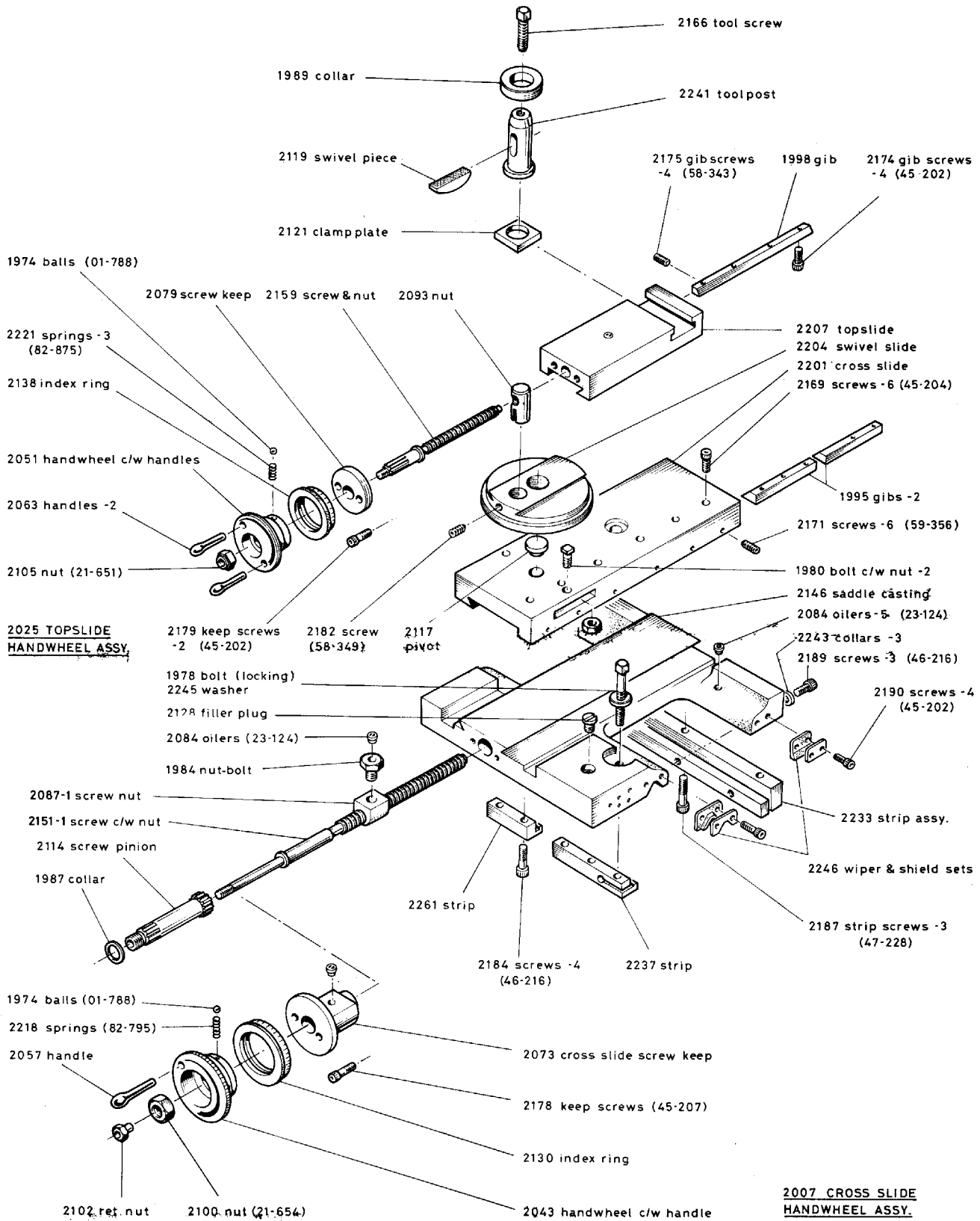

SADDLE LUB.

FROM SER. No. 5900
TO SER. No.

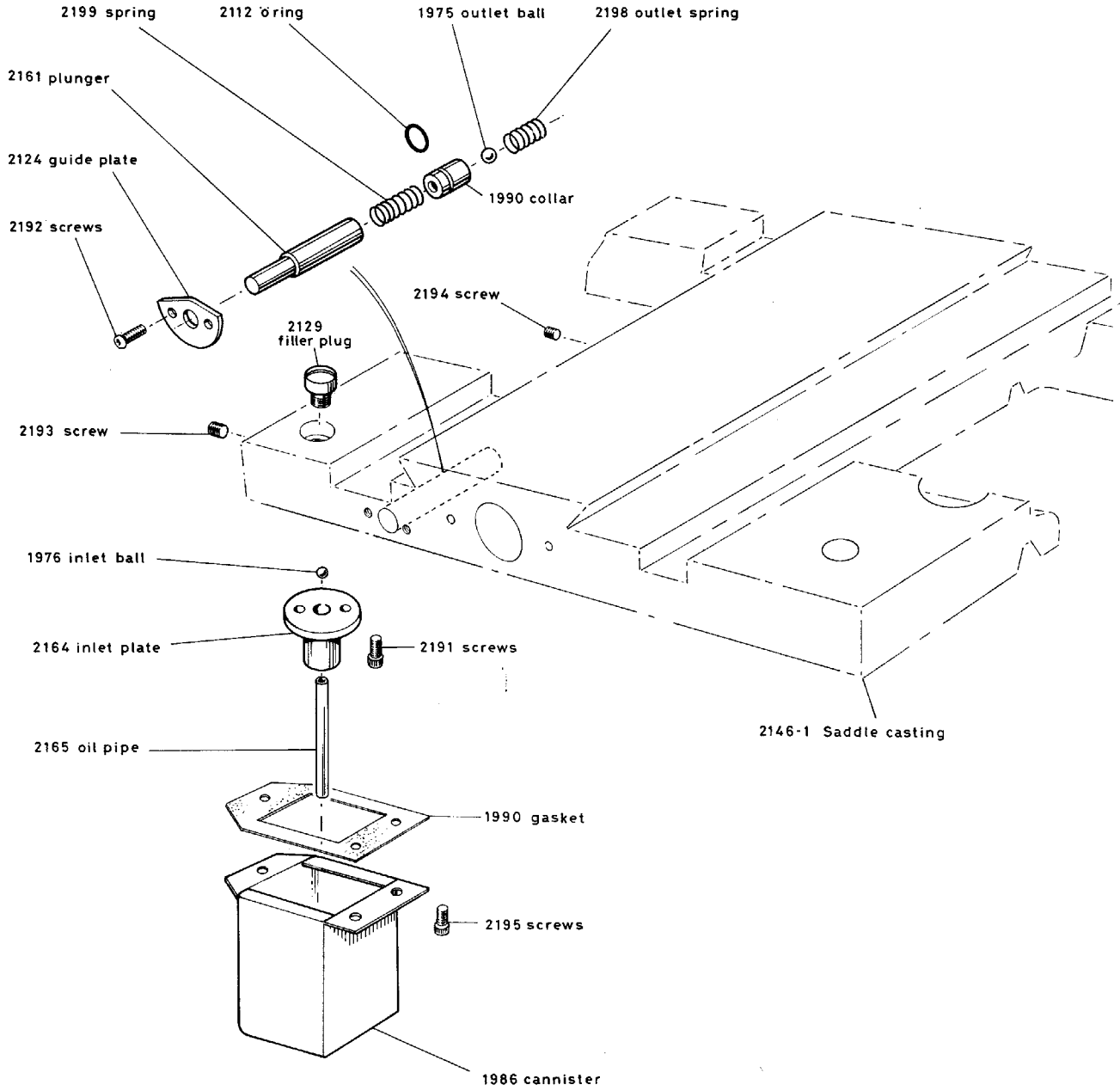

TAILSTOCK

FROM SER.No. 3257
TO SER.No.

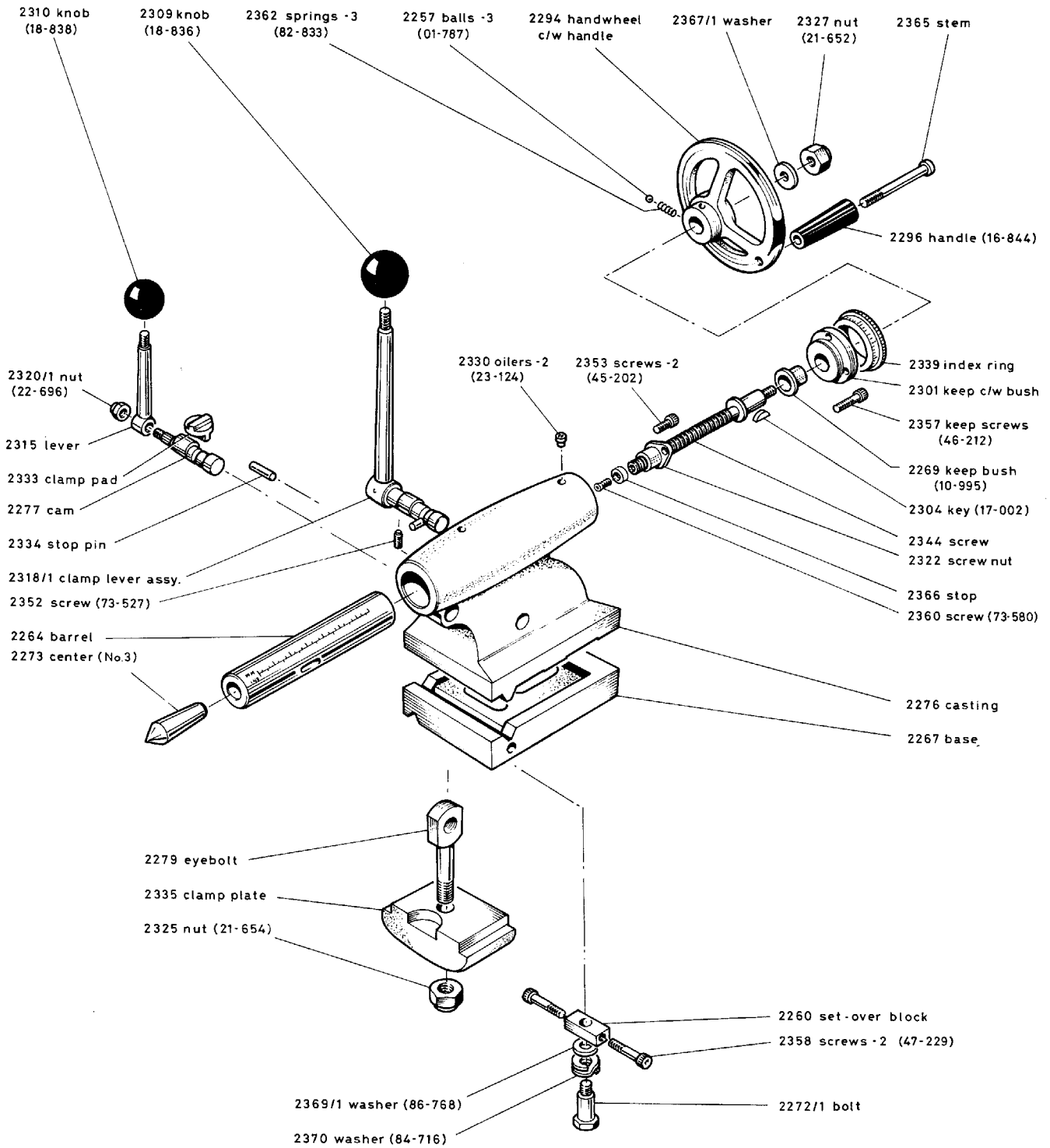

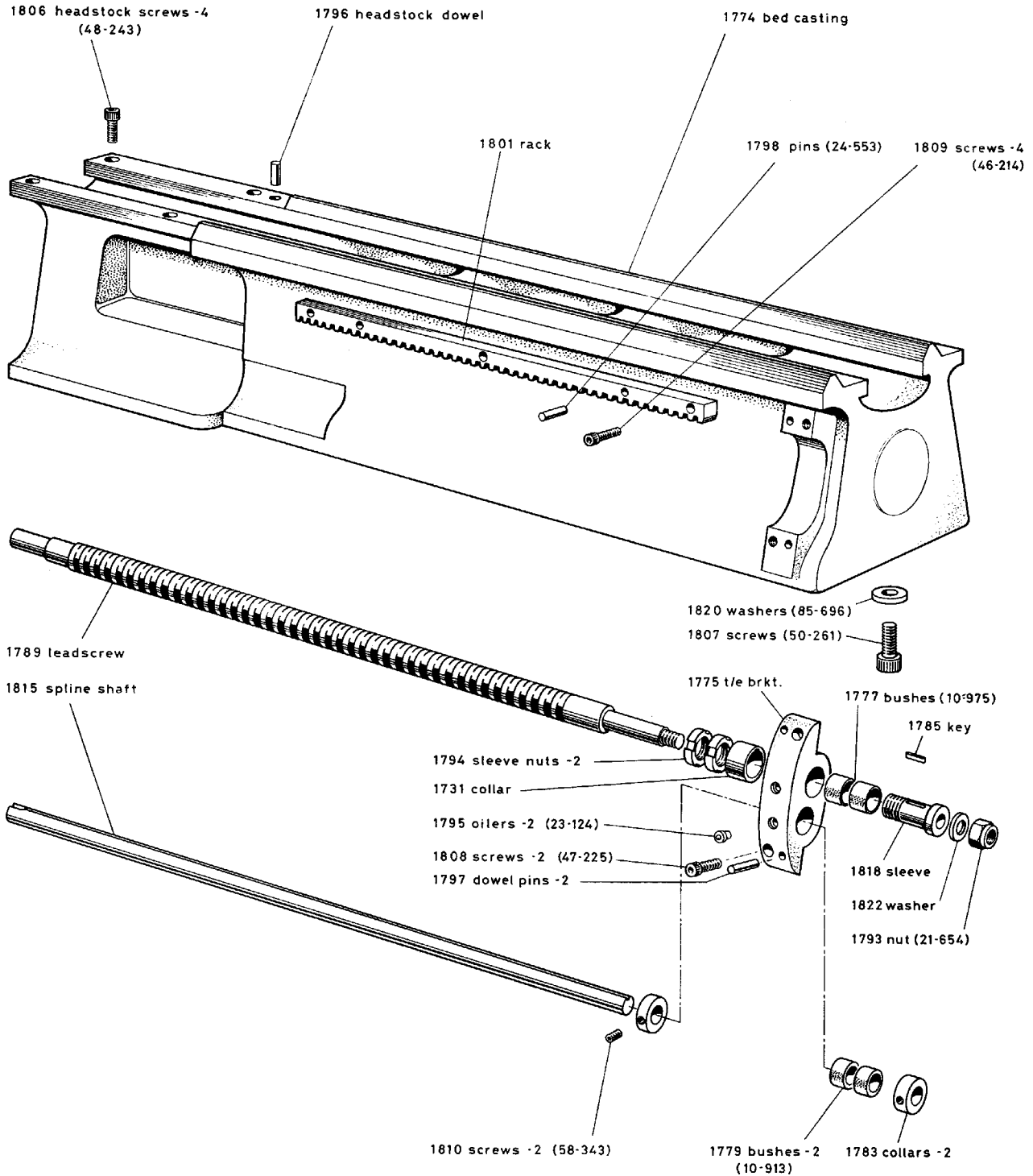

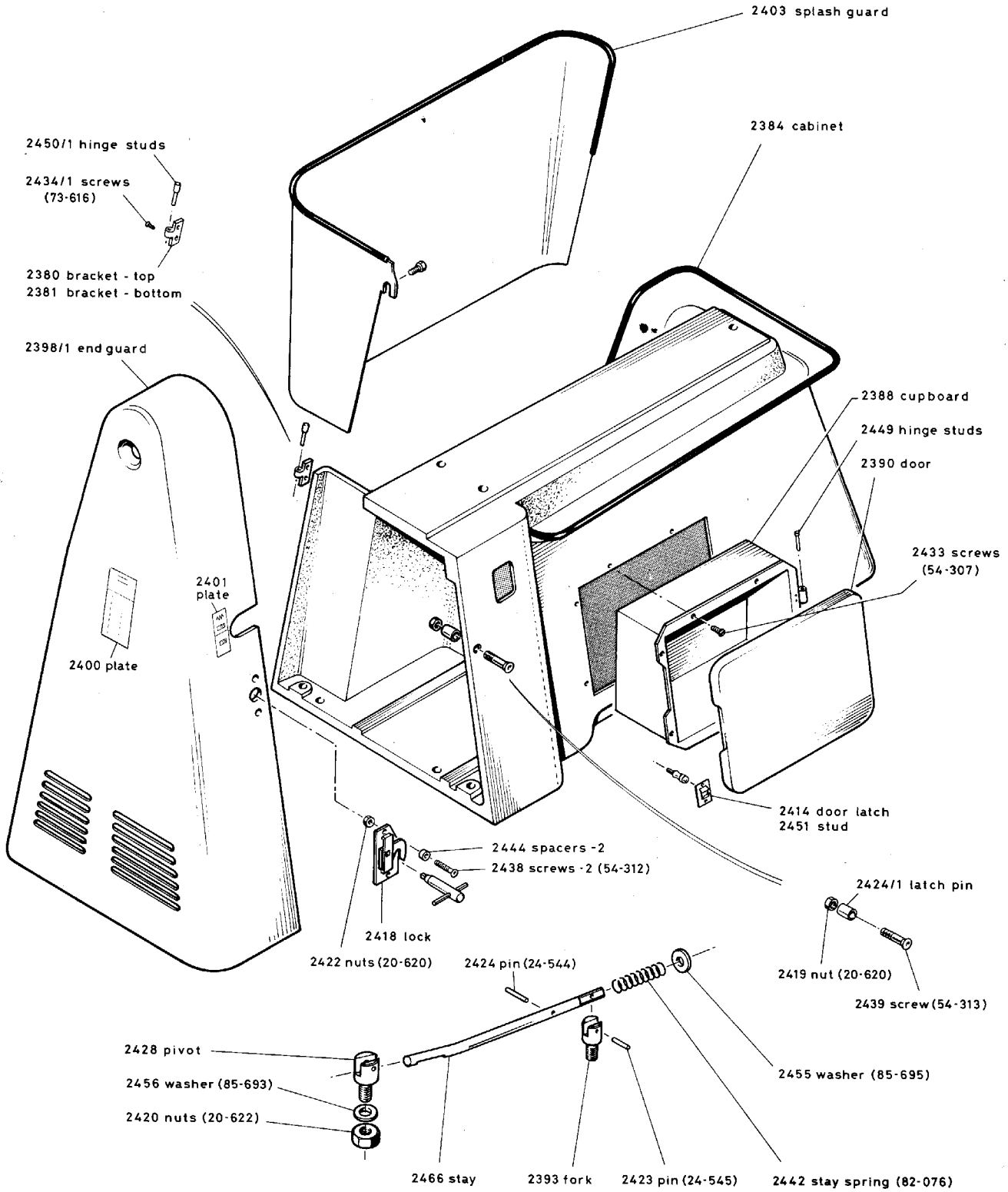

TRANSMISSION

FROM SER.No. 4835
TO SER.No.

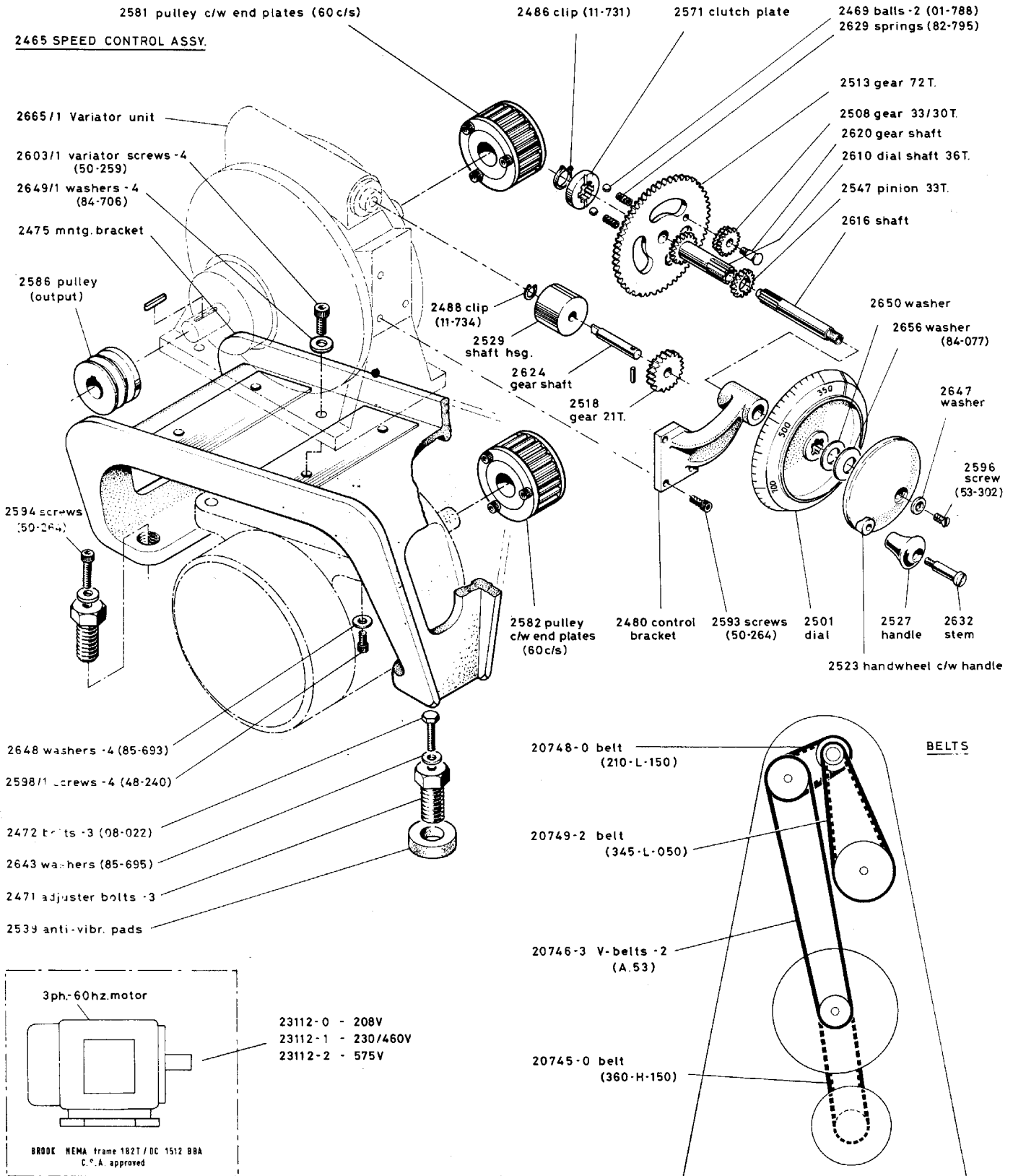

VARIATOR

FROM SER. No. 6188
TO SER. No.

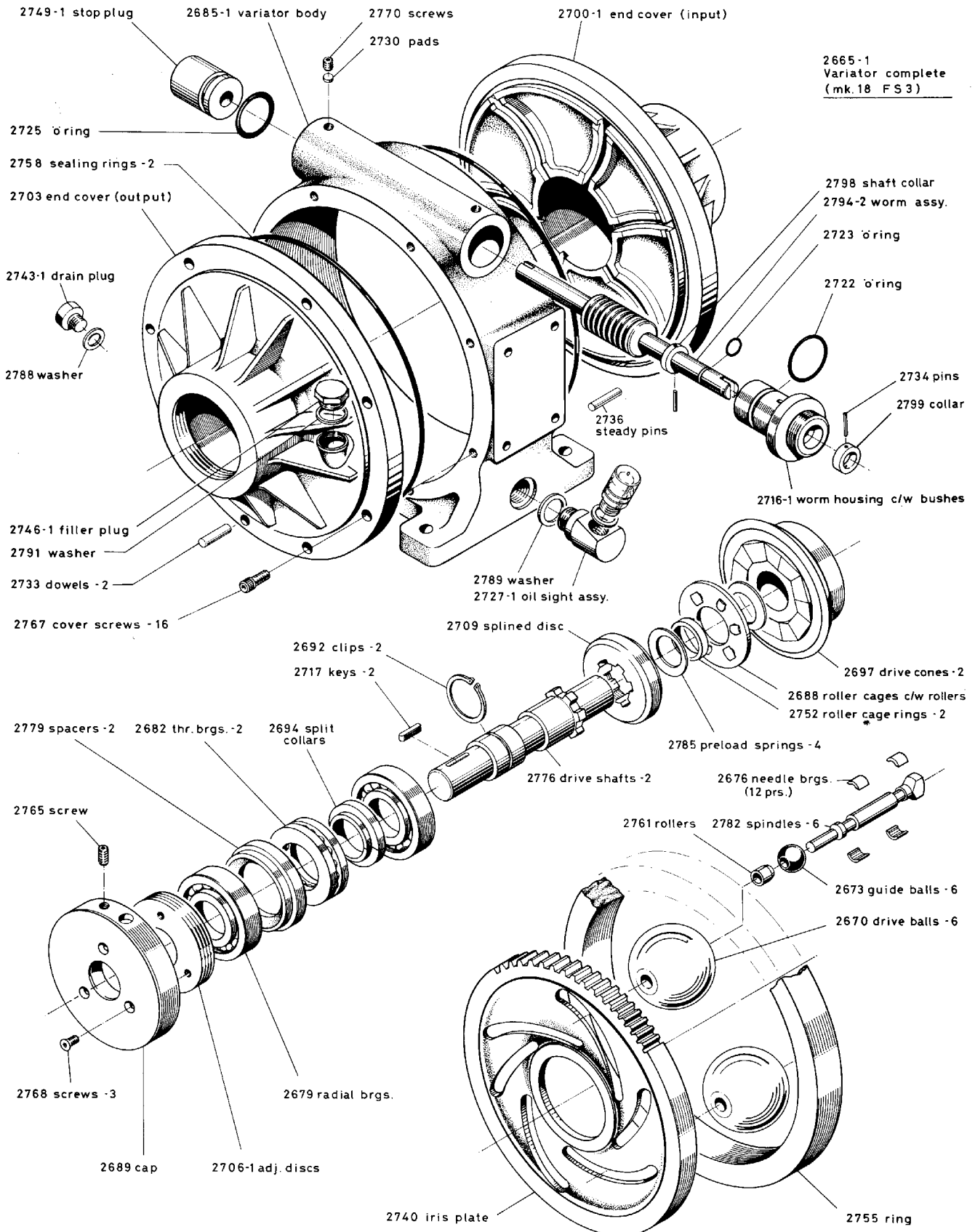

AA-14-7308

COOLANT

FROM SER. No. 2049
TO SER. No.

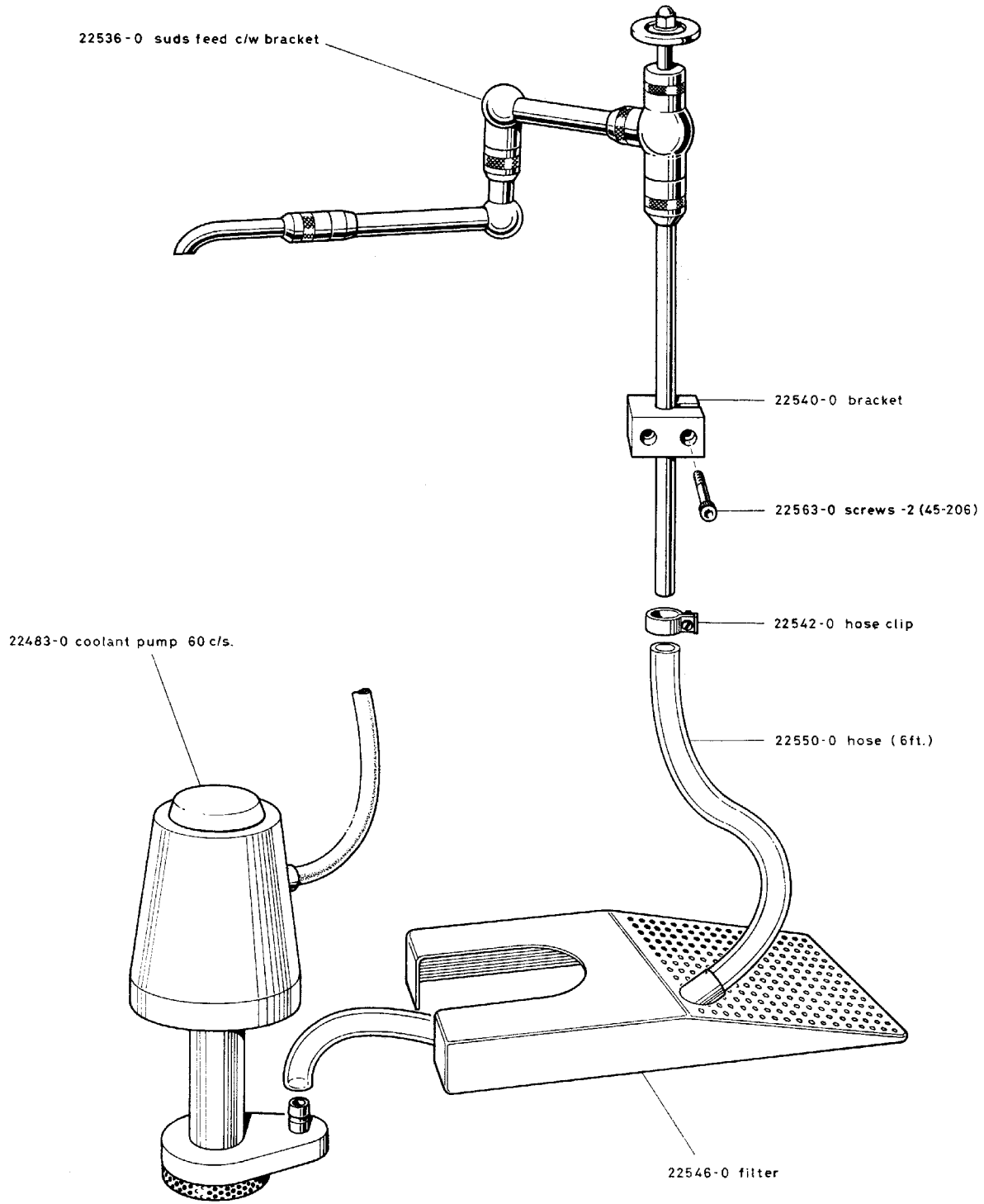

ELECTRICAL

FROM SER. No. 4835
TO SER. No.

IMPORTANT :- state supply voltage
when ordering.

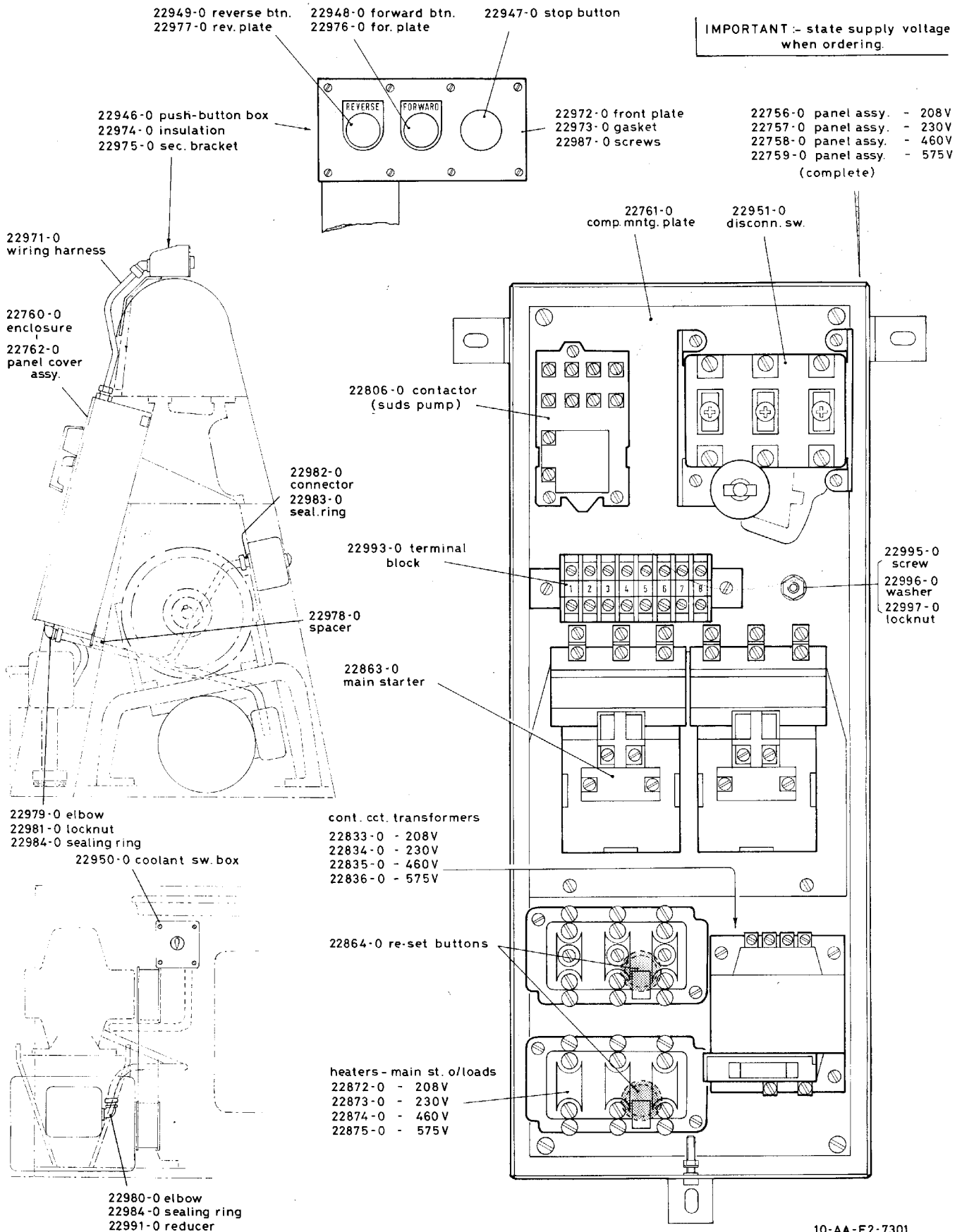

10-AA-E2-7301

CAPSTAN ATTACHMENT

FROM SER. NO. 4209
TO SER. NO.

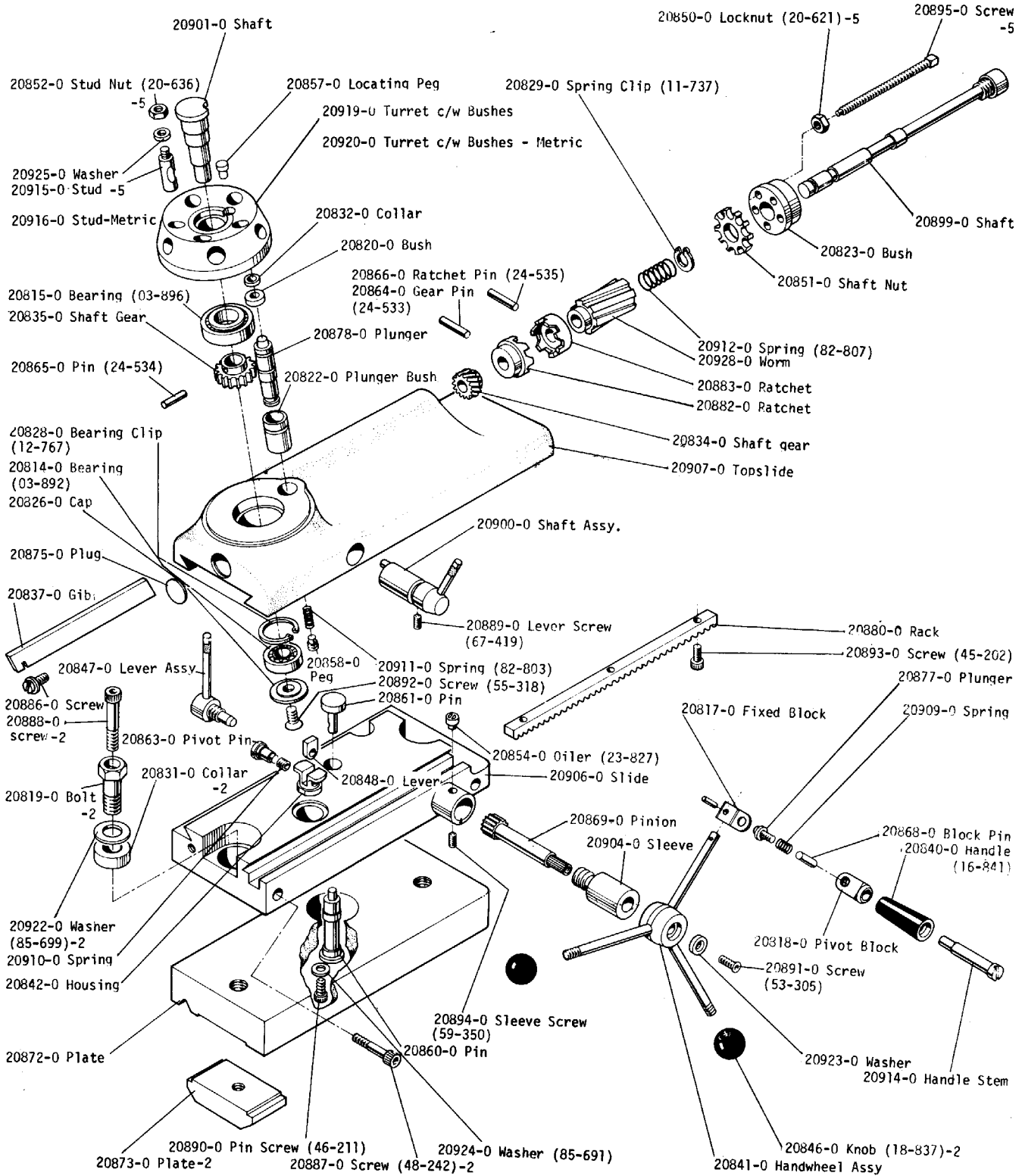

TAPER TURNER

FROM SER. No. 1240
TO SER. No.

25140-1 COMPLETE ASSY.

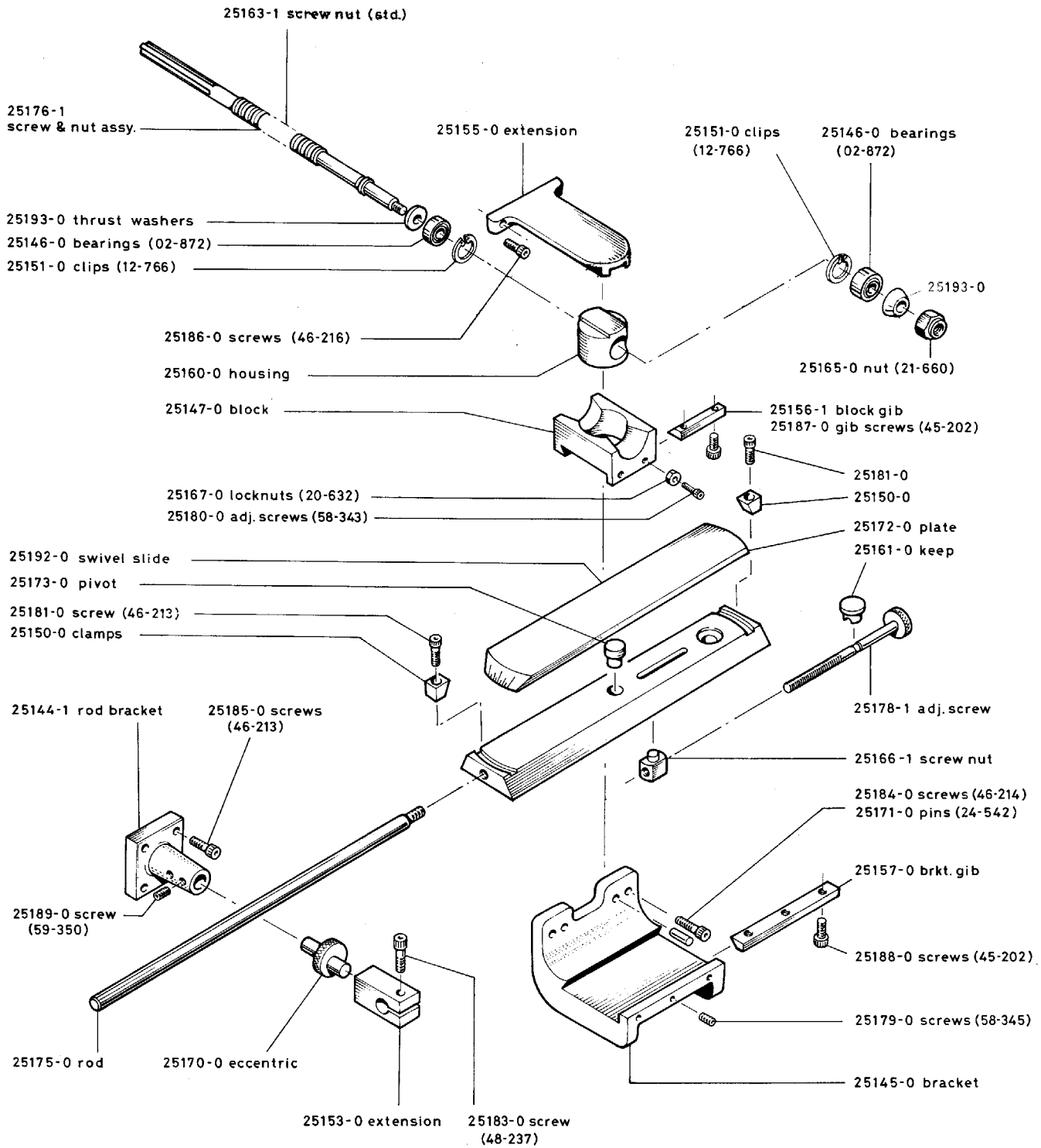

BEDSTOPS

FROM SER. NO.
TO SER. NO.

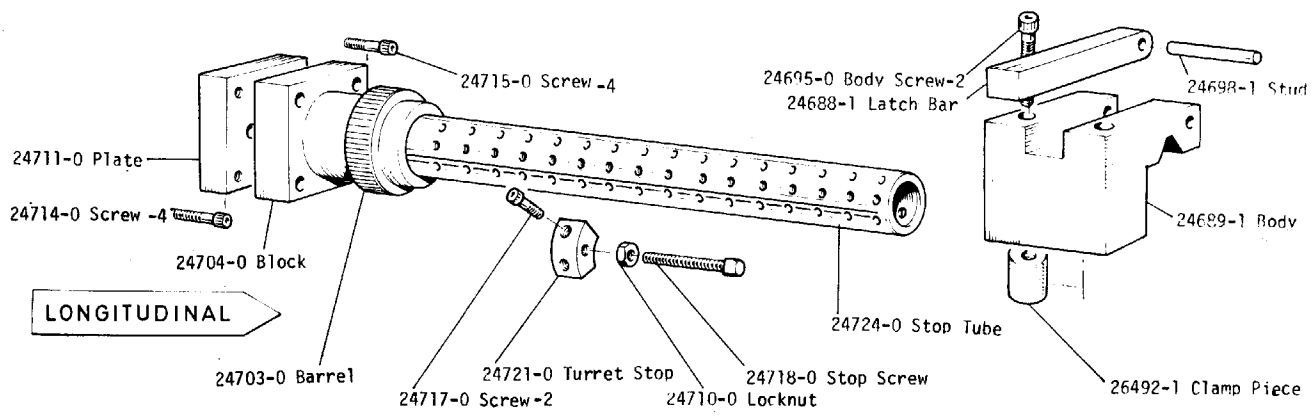
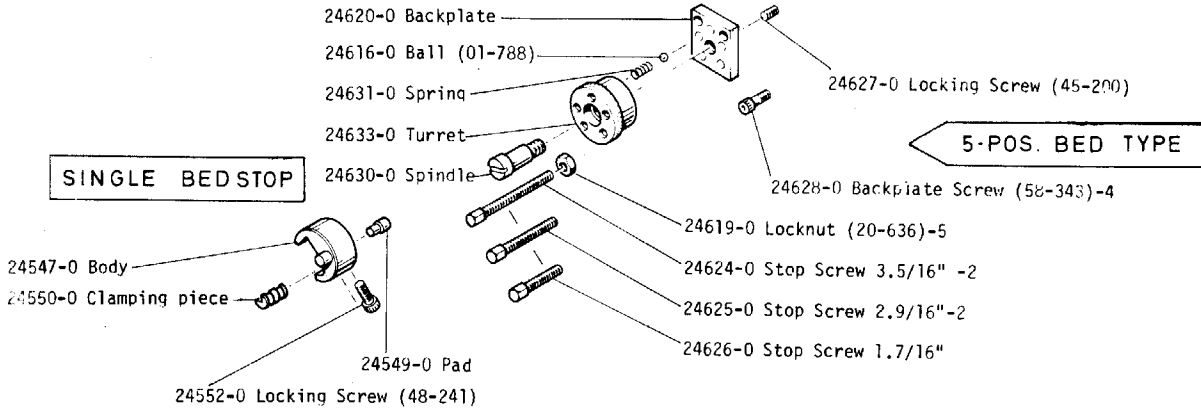
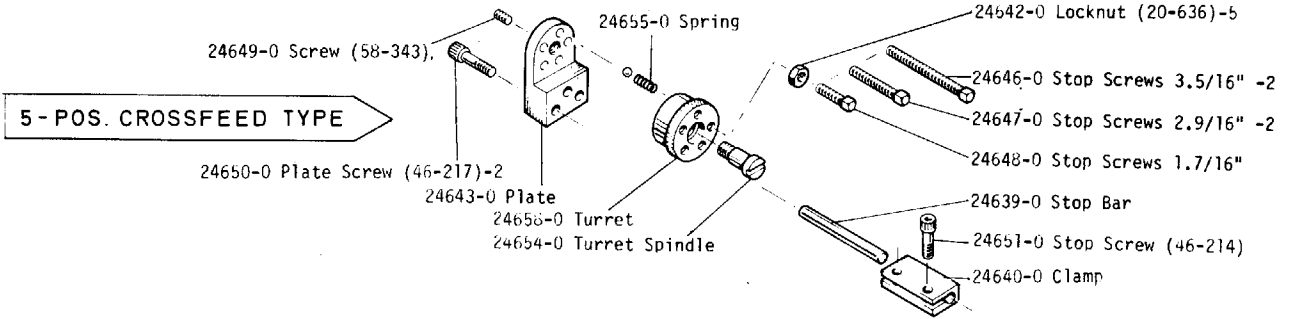
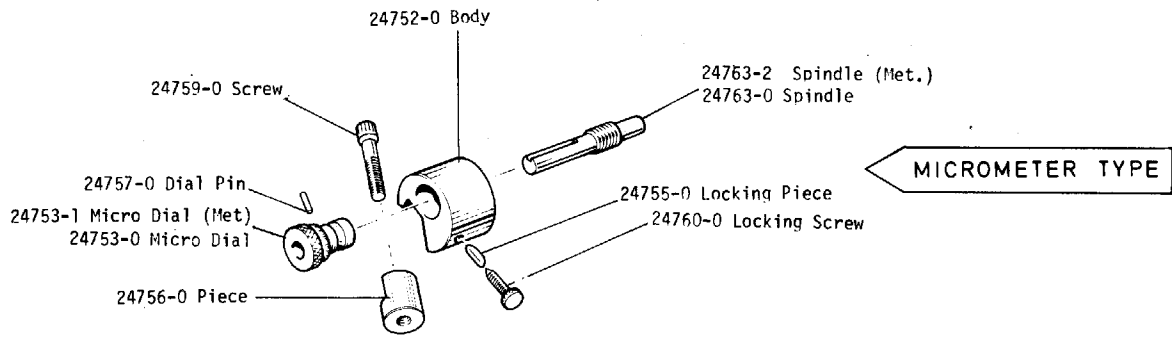

STEADIES; TRAVELLING/STATIONARY

FROM SER. NO.
TO SER. NO.

TRAVELLING

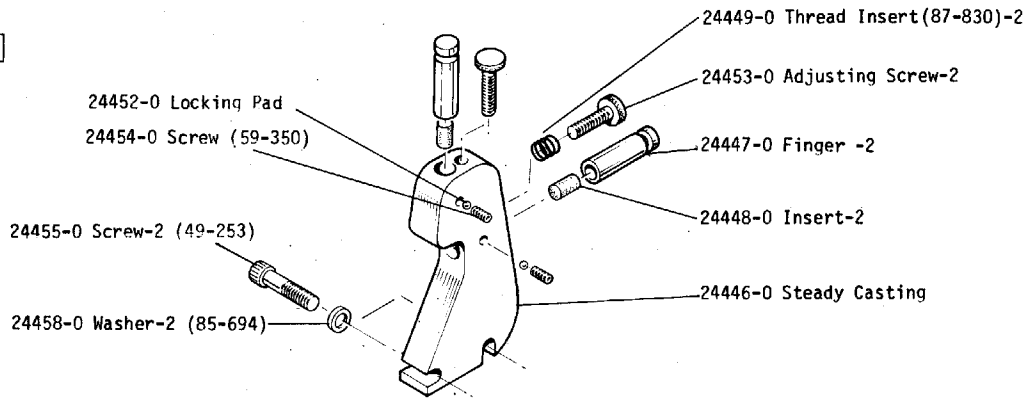

STATIONARY

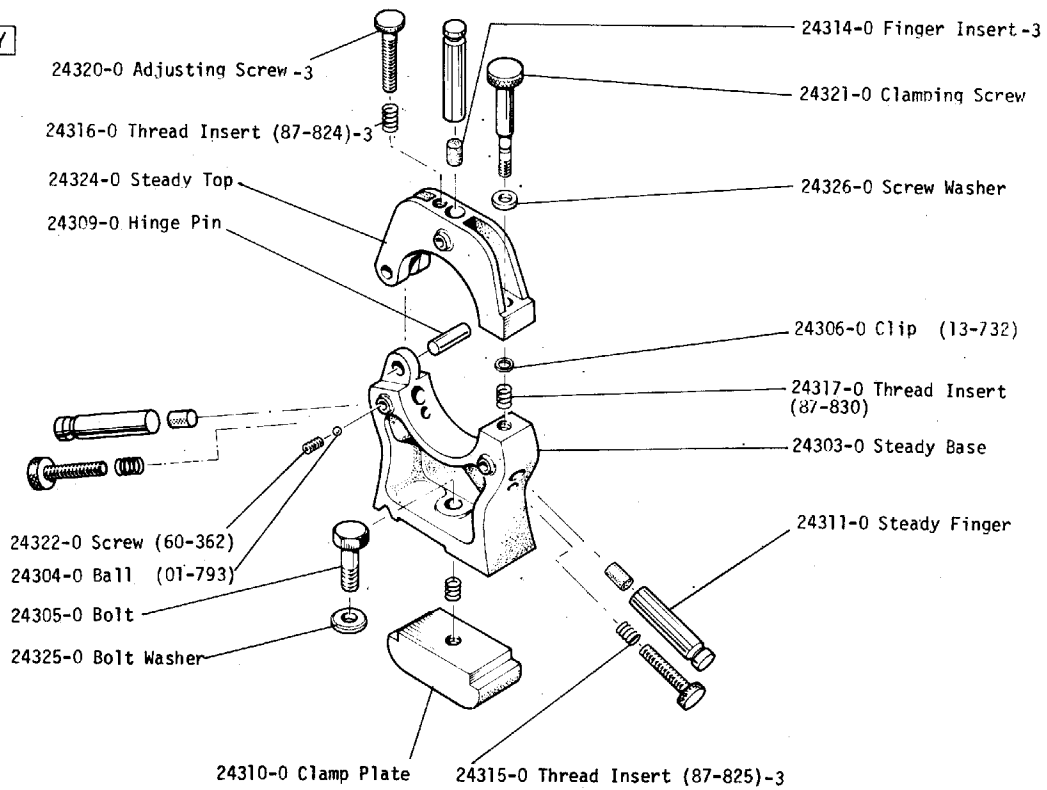

REAR TOOLPOST

FROM SER. NO.
TO SER. NO.

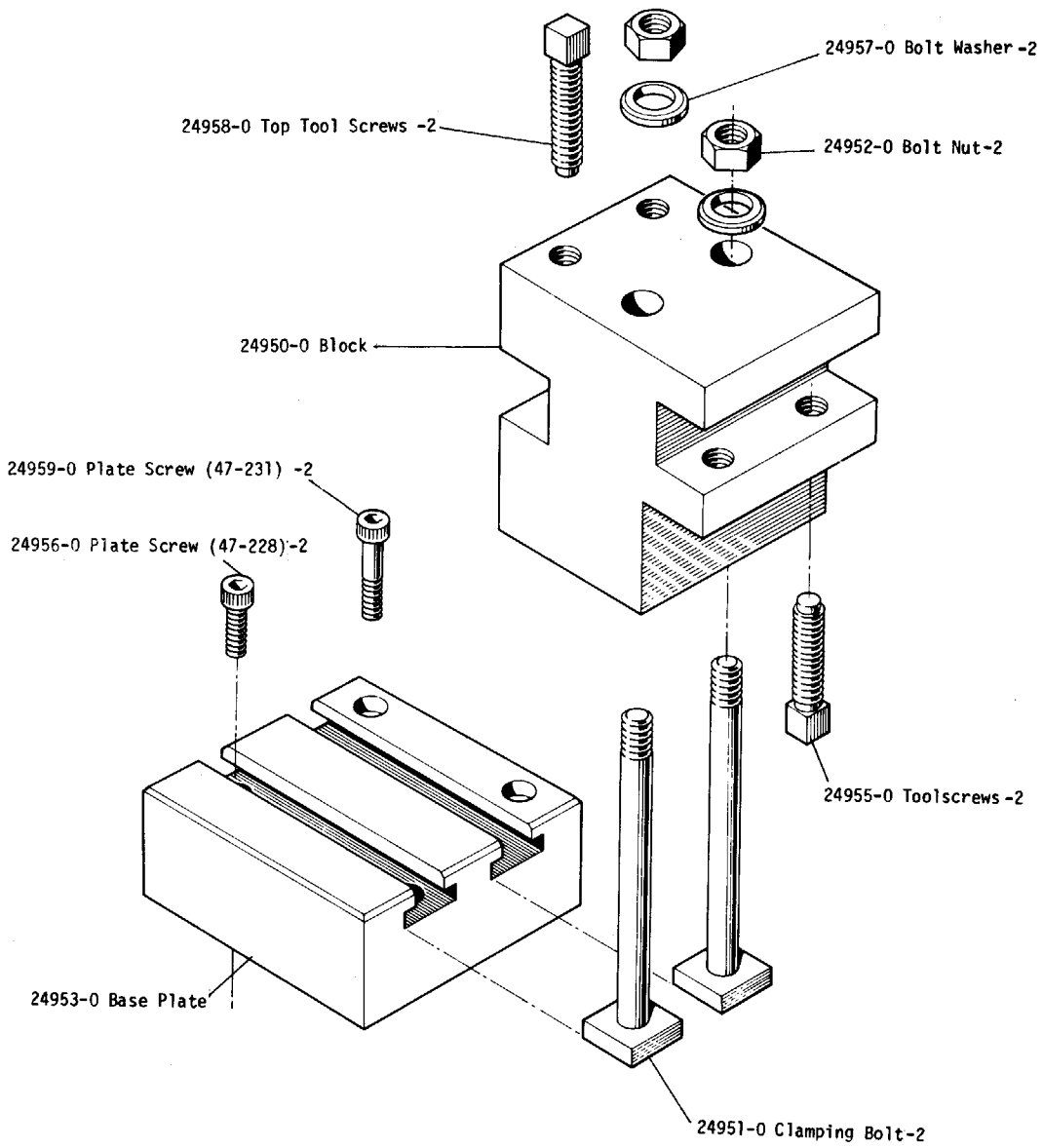

QUICK CHANGE TOOLPOST

FROM SER. NO.
TO SER. NO.

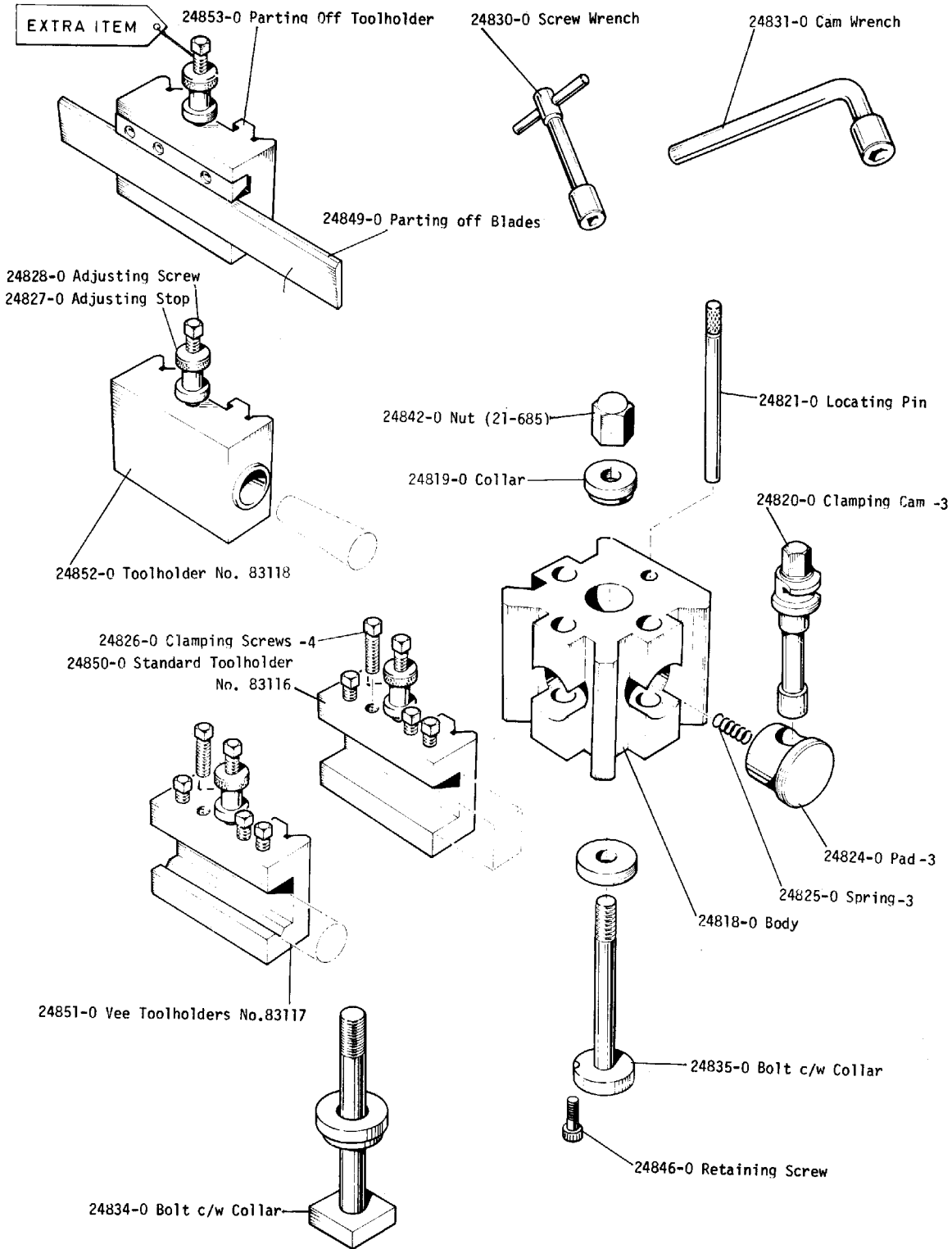

8 POSITION TOOLPOST

FROM SER. NO.
TO SER. NO.

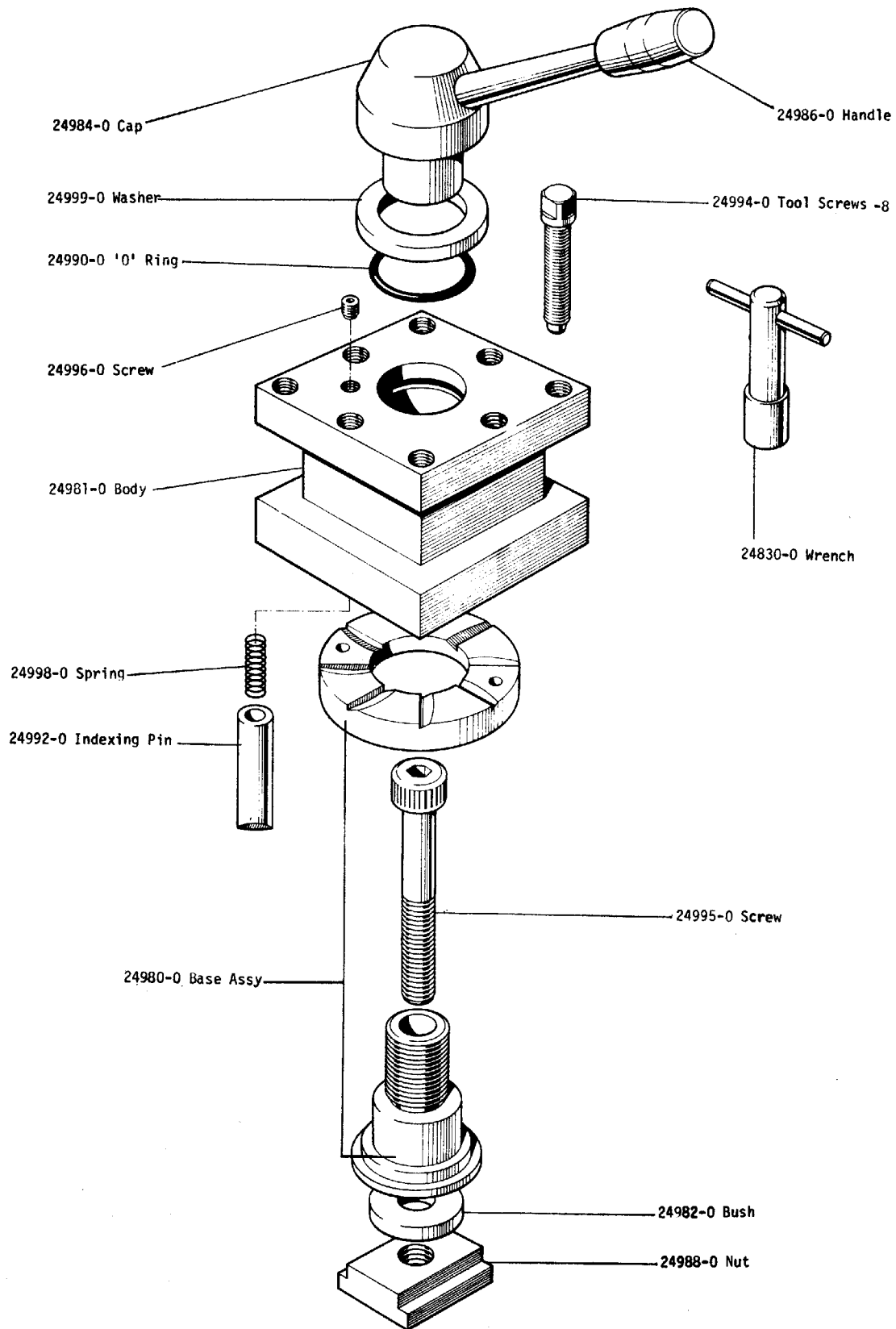

MAGNETIC CHIP GUARD/DIAL INDICATOR

FROM SER No.
TO SER No.

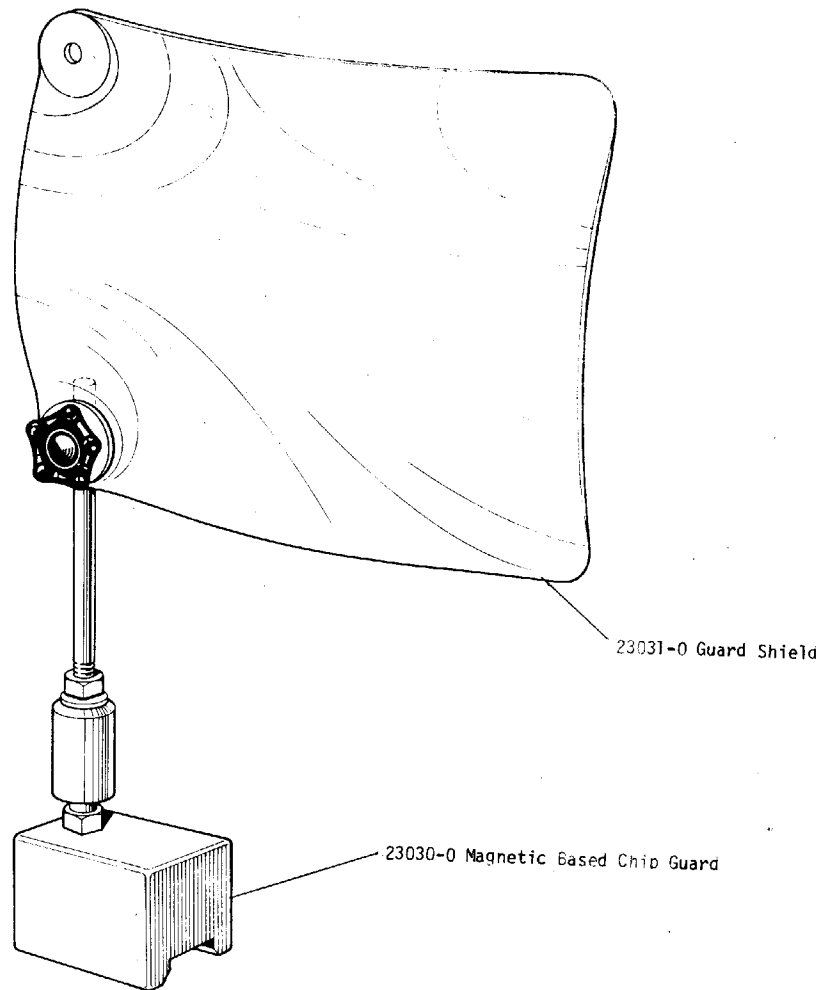

- 23032-0 Magnetic Based Dial Indicator Assy/English
- 23033-0 Magnetic Based Dial Indicator Assy/Metric

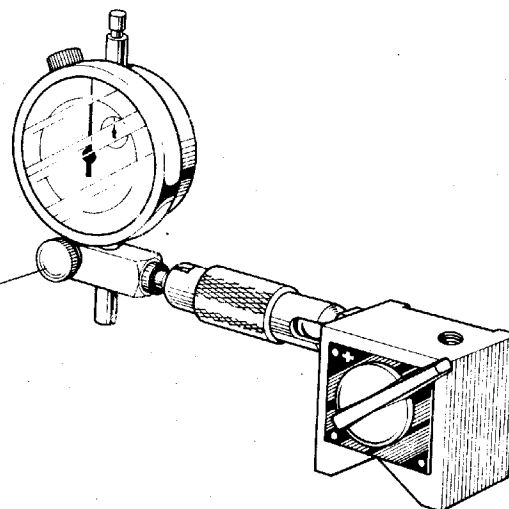

APPENDIX 1 - SPECIFICATIONS OF STANDARD PARTS.

<u>Item.</u>		
17-002	Woodruff Key	No. 9.
08-022	Hex. Head Bolt	1/2" UNC. x 3.1/2"
27-028	Oilring - Pioneer P.O. 20017513	1.7341" Dia. x .139" Thick.
031	3.1/2" Coventry Matrix Clutch Unit	
82-063	Compression Spring - Flexo 163208	1" F.L. over 11/32" rod
82-066	Compression Spring	.237" O/D x 1.1/8" Free length
79-069	Oilseal - Weston 913708225	
88-070	Solid Gas Plug	3/8"
79-071	Oilseal - Angus MS 012	
88-073	Tecalomit No. 4336-2 90° M & F Elbow	
88-074	Spire SRV 1590 (A) Door Latch	
88-075	Spire SBV 1691 Door Latch Stud	
82-076	Compression Spring	.500" I/D x 3" F.L.
84-077	Terrys Belville Washer No.10	
83-083	4 OW. Stepdown Transformer	Primary 220/440/550V.
15-084	Fuse Holder	Slydlok 5 amp.
83-085	Underwood Transformer 1/BIAR	Input 250/500V.
		Output 9V. 1.1/2 amp.
83-086	Micro Switch	Burgess MK.3BR. 600V. 2 amp.
83-087	Crabtree Moving Contact	16000/13
83-088	Crabtree Fixed Contact	16000/11
83-089	Crabtree Cable Clamp Assembly	16000/19
15-090	9V. 1.1/2 amp. Screw Type Bulb	
15-091	Bulb Holder	Bulgin L.E.S. 1-1 MOD.
83-092	Crabtree Overload Release Unit	16007
83-093	Crabtree Magnet Coil	
	200/220V.	16000/1A
	220/240V.	16000/2B
	240/265V.	16000/3C
	275/300V.	16000/4D
	330/365V.	16000/5E
	365/400V.	16000/6F
	380/420V. (Standard)	16000/9J
	400/440V.	16000/7G
	440/480V.	16000/10K
	500/550V.	16000/8H
83-094	Crabtree Air Brake Starter	Interior Type B.15
		16107/3/J
83-095	Crabtree Moving Contact Assembly	28011
83-096	Crabtree Auxilary Contact Assembly	16021
84-097	Tag Washer	4 B.A.
84-098	Shakeproof Washer	3/16"
84-099	Solder Tag Washer	3/16"
83-100	Crabtree Magnet Assembly	16000/20
15-101	Two Pin Socket	TM 316
14-104	Split Dowel Pin	1/8" dia. x 3/4" long
82-105	Compression Spring	Flexo. 82504
82-107	Compression Spring	Flexo 62604
23-124	Oil Cup	Springwell 1/4"
45-201	Socket Cap Head Screw	No.10. 24 t.p.i. x 1/4"
45-202	Socket Cap Head Screw	No.10. 24 t.p.i. x 1/2"
45-203	Socket Cap Head Screw	No.10. 24 t.p.i. x 5/8"
45-204	Socket Cap Head Screw	No.10. 24 t.p.i. x 3/4"
45-207	Socket Cap Head Screw	No.10. 24 t.p.i. x 1.1/4"
45-210	Socket Cap Head Screw	No.10. 24 t.p.i. x 2"

SPECIFICATIONS OF STANDARD PARTS (CONTINUED)

Item.

46-211	Socket Cap Head Screw	1/4" UNC x 3/8"
46-212	Socket Cap Head Screw	1/4" UNC x 1/2"
46-213	Socket Cap Head Screw	1/4" UNC x 5/8"
46-214	Socket Cap Head Screw	1/4" UNC x 3/4"
46-215	Socket Cap Head Screw	1/4" UNC x 7/8"
46-216	Socket Cap Head Screw	1/4" UNC x 1"
46-217	Socket Cap Head Screw	1/4" UNC x 1.1/4"
46-218	Socket Cap Head Screw	1/4" UNC x 1.1/2"
47-227	Socket Cap Head Screw	5/16" UNC x 1"
47-228	Socket Cap Head Screw	5/16" UNC x 1.1/4"
47-230	Socket Cap Head Screw	5/16" UNC x 1.3/4"
47-231	Socket Cap Head Screw	5/16" UNC x 2"
47-233	Socket Cap Head Screw	5/16" UNC x 2.1/2"
48-239	Socket Cap Head Screw	3/8" UNC x 7/8"
48-240	Socket Cap Head Screw	3/8" UNC x 1"
48-243	Socket Cap Head Screw	3/8" UNC x 1.3/4"
48-249	Socket Cap Head Screw	3/8" UNC x 4"
49-253	Socket Cap Head Screw	7/16" UNC x 2"
50-259	Socket Cap Head Screw	1/2" UNC x 1.1/4"
50-264	Socket Cap Head Screw	1/2" UNC x 3.1/2"
53-302	Socket Countersunk Head Screw	No. 10-24 t.p.i. x 3/8"
53-303	Socket Countersunk Head Screw	No. 10-24 t.p.i. x 1/2"
53-305	Socket Countersunk Head Screw	No. 10-24 t.p.i. x 3/4"
54-307	Socket Countersunk Head Screw	1/4" UNC x 3/8"
54-309	Socket Countersunk Head Screw	1/4" UNC x 5/8"
55-318	Socket Countersunk Head Screw	5/16" UNC x 3/4"
58-343	Socket Head Set Screw	No. 10-24 t.p.i. x 1/4"
58-344	Socket Head Set Screw	No. 10-24 t.p.i. x 5/16"
58-345	Socket Head Set Screw	No. 10-24 t.p.i. x 3/8"
59-350	Socket Head Set Screw	1/4" UNC x 1/4"
59-352	Socket Head Set Screw	1/4" UNC x 3/8"
59-356	Socket Head Set Screw	1/4" UNC x 3/4"
60-362	Socket Head Set Screw	5/16" UNC x 3/8"
61-371	Socket Head Set Screw	3/8" UNC x 1/2"
61-372	Socket Head Set Screw	3/8" UNC x 5/8"
67-418	Socket Head Set Screw	1/4" UNC x 5/16"
67-419	Socket Head Set Screw	1/4" UNC x 3/8"
68-433	Socket Head Set Screw	5/16" UNC x 3/4"
69-438	Socket Head Set Screw	3/8" UNC x 3/8"
73-470	Cheese Head Screw	6 B.A. x 3/8"
73-471	Cheese Head Screw	4 B.A. x 1"
73-474	Cheese Head Screw	4 B.A. x 3/4"
73-483	Cheese Head Screw	2 B.A. x 5/8"
73-485	Cheese Head Screw	2 B.A. x 3/8"
73-512	Countersunk Head Self Tapping Screw	7/64" Dia.
73-517	Socket Countersunk Head Screw	2 B.A. x 7/8"
73-518	Countersunk Head Screw	2 B.A. x 1/2"
73-519	Socket Cap Head Screw	2 B.A. x 3/4"

SPECIFICATIONS OF STANDARD PARTS (CONTINUED)

Item.

24-525	Mills Pin G.P.3.	1/8" Dia.	x	9/16"
24-526	Mills Pin G.P.3.	1/8" Dia.	x	5/8"
24-527	Mills Pin G.P.4	1/8" Dia.	x	3/8"
24-531	Mills Pin G.P.3.	5/32" Dia.	x	3/8"
24-532	Mills Pin G.P.3.	5/32" Dia.	x	1/2"
24-533	Mills Pin G.P.3.	5/32" Dia.	x	3/4"
24-534	Mills Pin G.P.3.	5/32" Dia.	x	1"
24-535	Mills Pin G.P.3.	5/32" Dia.	x	1.1/4"
24-538	Mills Pin G.P.1.	3/16" Dia.	x	1.1/8"
24-548	Mills Pin G.P.11.	3/16" Dia.	x	1.1/16"
24-553	Mills Pin G.P.2.	1/4" Dia.	x	1"
25-561	Mills Pin G.P.5.	1/4" Dia.	x	3/4"
24-572	Mills Pin G.P.3.	5/16" Dia.	x	1"
14-605	Grover Spring Valve Pin	3/16" Dia.	x	3/4"
14-606	Grover Pin	3/16" Dia.	x	7/8"
20-620	Standard Nut - Steel	1/4" UNC		
20-621	Standard Nut - Steel	5/16" UNC		
20-622	Standard Nut - Steel	3/8" UNC		
20-623	Standard Nut - Steel	7/16" UNC		
20-632	Standard Nut - Steel	No. 10-24 t.p.i.		
20-634	Standard Nut - Steel	2 B.A.		
20-636	Standard Nut - Steel	3/8" UNC		
20-637	Thin Locknut	3/8" UNC		
21-651	Nyloc Nut	7/16" UNF		
21-654	Nyloc Nut	5/8" UNF		
21-659	Simmonds Aero Nut	5/16" UNC		
21-660	Simmonds Aero Nut	3/8" UNC		
21-662	Nyloc Nut NT/N166	1/2" UNC		
21-665	Standard Self-Locking Nut	5/8" UNC		
21-673	Locking Nut	1/2" UNF	Simmonds type	NT/D146
85-690	B.S. Steel Washer	3/16" I/D		
85-691	B.S. Steel Washer	1/4" I/D		
85-693	B.S. Steel Washer	3/8" I/D		
85-695	B.S. Steel Washer	1.1/2" I/D		
85-696	B.S. Steel Washer	1/2" I/D		
85-699	B.S. Steel Washer	3/4" I/D		
84-716	Double Coil Spring Washer-Light-Series	1/2" I/D		
84-727	Tab Washer	3.3/4" O/D	x 2.260" I/D	x .169"
13-732	External Circlip-Type 700/37A-Anderton.	3/8" Dia.		
11-736	External Circlip-Type 1400-Anderton	1/2" Dia.		
11-737	External Circlip-Type 1500-E.396-Anderton	1/2" Dia.		
11-740	External Circlip-Seager	1/2" Dia.		
13-742	External Circlip-Type 5101/56-Salter-Bowed External.	9/16" Dia.		
11-743	External Circlip-Type 1400-Anderton	5/8" Dia.		
11-745	External Circlip-Type 5101/66-Salter	3/4" Dia.		
11-746	External Circlip-Type 1500/E520	3/4" Dia.		
11-747	External Circlip-Seager	3/4" Dia.		

SPECIFICATIONS OF STANDARD PARTS (CONTINUED)

Item.

11-749	External Circlip-Type 5101/66-Salter	7/8"	Dia.
11-756	External Circlip-Seager	1.1/4"	Dia.
11-757	External Circlip-Type 1400-Anderton	2"	Dia.
12-766	Internal Circlip-Type 1300-Anderton	28 mm	Dia.
12-767	Internal Circlip-Type 1300-Anderton	40 mm	Dia.
12-771	Internal Circlip-Seager	83 mm	Dia.
11-777	External Circlip-Type 1500-E.580-Anderton	3/4"	Dia.
13-785	Internal Circlip-Bevelled Type-5002-206-Salter	2.1/16"	Dia.
01-787	Steel Ball	3/16"	Dia.
01-788	Steel Ball	1/4"	Dia.
01-793	Pho. Bronze Ball	1/4"	Dia.
82-695	Compression Spring	1/4"	O/D x 1/2" F.L. x 22 SWG
82-802	Compression Spring - Flexo 93016	1/4"	O/D x 2" F.L.
82-807	Compression Spring - Flexo 223413	11/16"	O/D x 1.1/2" F.L. x 16 SWG
87-824	Heli-Coil Inserts	3/8"	UNC x 9/16"
87-825	Heli-Coil Inserts	1/2"	UNC
23-827	Garland Diaphragm Oiler	1/4"	Dia.
18-834	Plastic Knob - Red	1.1/4"	Dia. x 7/16" UNC
18-837	Plastic Knob - Cream	1.1/4"	Dia. x 3/8" UNC
18-839	Plastic Knob - Cream	1"	Dia. x 3/8" UNC
16-842	Plastic Handle	7/8"	Dia. x 3"
16-843	Plastic Handle	1.3/4"	Dia. x 1.11/16"
26-845	Oilring - Pioneer P.O. 05003707	.364"	I/D x .070" Thick
27-846	Oilring - Pioneer P.O. 06204310	.424"	I/D x .103" Thick
26-849	Oilring - Pioneer P.O. 10008110	.799"	I/D x .103" Thick
27-850	Oilring - Pioneer P.O. 11208713	.859"	I/D x .139" Thick
26-851	Oilring - Pioneer P.O. 12510013	.984"	I/D x .070" Thick
26-856	Oilring - Pioneer P.O. 22520013	1.984	I/D x .139" Thick
26-859	Oilring - Dowty No.2	1/2"	I/D x 5/8" O/D x 1/16"
79-864	Oilseal - Weston W.17510025 R4	1"	I/D x 1.3/4" O/D x 1/4"
79-867	Oilseal - Weston W.18713731	1.3/8"	I/D x 1.7/8" O/D x 5/16"
79-868	Oilseal - Weston W.21916237	1.5/8"	I/D x 2.3/16" O/D x 3/8"
79-869	Grease Ring - Nylos 6205 J.V.	52 mm	O/D
80-871	Oilsight - Tecalemit I.C. 4610	1.1/4"	O/D
02-872	Ball Journal	Hoffmann	A.10
02-874	Ball Journal	Hoffmann	A.15
02-876	Ball Journal	Hoffmann	S. 9
02-877	Ball Journal	Hoffmann	S.10
02-879	Ball Journal	Hoffmann	XLS.2
03-890	Needle Roller INA Sc.68	3/4"	Bore x 9/16" O/D x 1/2"
03-891	Needle Roller INA Sc.98	9/16"	Bore x 3/4" O/D x 1/2"
03-892	Taper Roller K.G.S. KE 30203	17 mm	Bore x 40 mm O/D x 13 mm

SPECIFICATIONS OF STANDARD PARTS (CONTINUED)

Item.

03-896	Taper Roller K.G.S. KE 30205	25 mm Bore x 52 mm O/D x 16 mm
03-897	Needle Roller INA Sc. 1612	1" Bore x 1.1/4" O/D x 1"
03-898	Needle Roller INA Sc. 188	1.1/8" Bore x 1.3/8" O/D x 1/2"
10-926	Oilite Bush	3/4" Bore x 1" O/D x 1.1/8"
07-949	Vee Belt	A.53
06-960	Powergrip Belt	210 L 150
06-961	Powergrip Belt	345 L 050
06-962	Powergrip Belt	360 L 150
83-995	Isolating Switch - Santon	SR - 237
83-996	Start and Reverse Switch - Craig & Derricot	RT 3039 AS

MATRIX CLUTCH.

Standard Parts A - N listed on Page 3.

MK. 17 KOPP VARIATOR.

All Standard Parts listed on Page 33.

INSTRUCTION & PARTS MANUAL

HARRISON Model 10-AA high-speed precision lathe

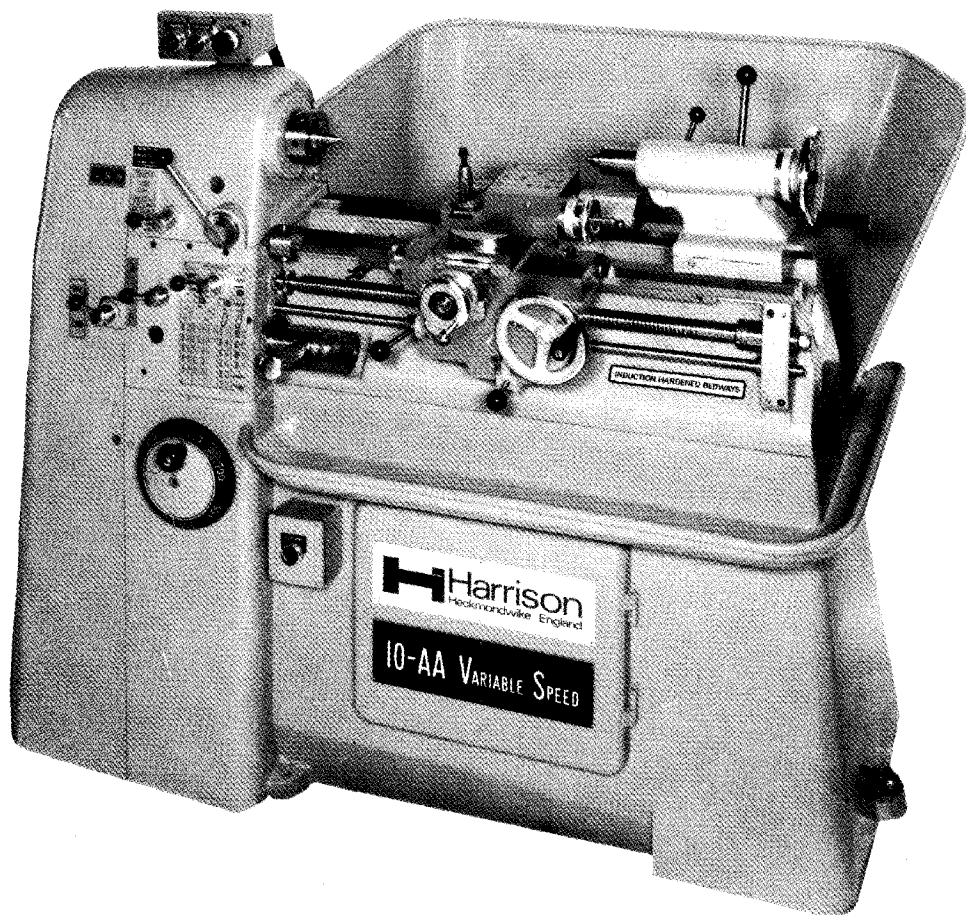

This manual applies only to the machine having the serial number shown; this is carried on a red disc affixed on each major assembly and must be quoted in all communications regarding the lathe or repair parts.

Machine serial number

Printed in England

REM SALES INCORPORATED
WEST HARTFORD - CONNECTICUT 06107