

NOV 29 1977

PARTS - SALES - SERVICE
RICE MACHINERY, INC.
[Reynolds of Baker Street]
1104 Pontiac Ave. • Cranston, R. I. 02920
Telephone 401 - 781-3010

J & S Fluidmotion WHEEL DRESSERS

0001 Accuracy • Dress Two Angles Tangent to a Radius
in One Continuous Motion

AUTOMATIC CENTERING OF DIAMOND

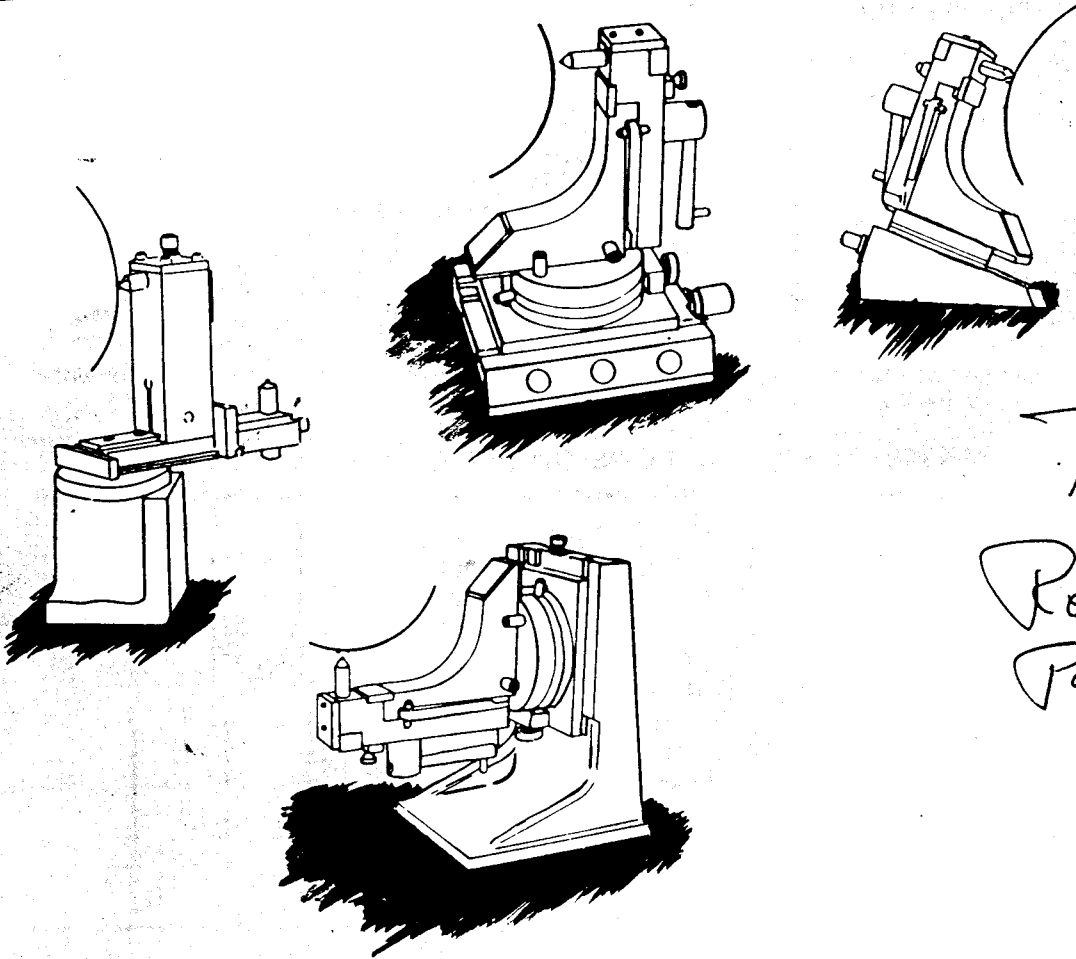
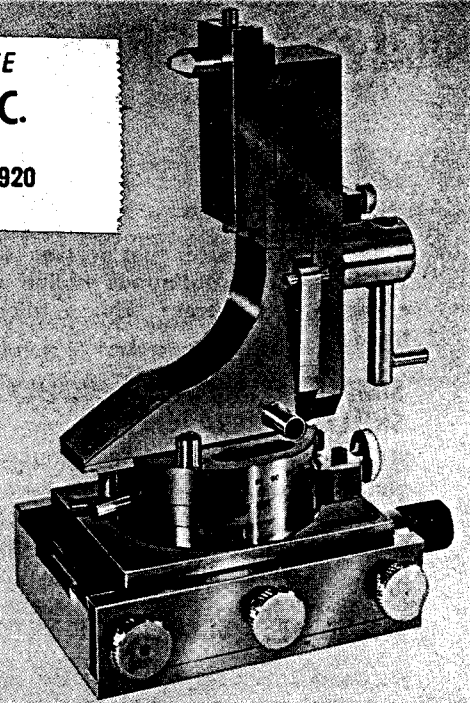

Roy
Reference
Pages # 9, 10 + 11
"Contour"
models

- TOOL AND CUTTER GRINDERS
- CYLINDRICAL GRINDERS
- UNIVERSAL GRINDERS
- SURFACE GRINDERS

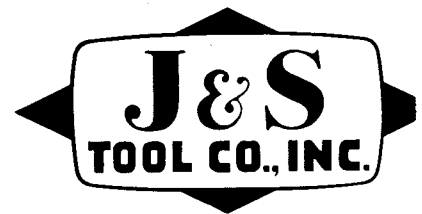

J & S TOOL COMPANY, INC.

70 OKNER PARKWAY • LIVINGSTON, NEW JERSEY 07039
TELEPHONE: (201) 992-8866, 7, 8, 9

FLUIDMOTION

- the wheel dresser that dresses two angles tangent to a radius in **one continuous motion** with **.0001 accuracy**.
- the wheel dresser with a micrometer feed— $1\frac{3}{16}$ " travel.

SIMPLE—ELIMINATES HIGHLY SKILLED OPERATORS

FLUIDMOTION means YOU CAN dress two angles tangent to a radius in one continuous motion—with only one setting. The diamond automatically returns to center position after dressing angles. Thus even a beginner can dress complex forms quickly and accurately.

ELIMINATES ELABORATE SETUPS

No need to pre-set diamond, or use any other tool except a micrometer and a simple hex wrench.

No Gage block—Master Gage setting—Jo Block—Parallel Bar—Surface Plate—Height Gage—Dial Indicator.

No movement of dovetails necessary to form angles. The angle is dressed by continuing to push handle in both directions after radius is formed.

No need to use Gibs & V-Ways other than positioning surfaces.

ACCURATE—RAPID, REPEAT FORM-DRESSING

FLUIDMOTION generates clean, precise wheel profiles entirely free of chatter marks. Without **FLUIDMOTION** a perfect blend of angles and radius is improbable.

If the models described in this booklet do not answer your particular grinding requirements, special dressing equipment can be furnished to your specifications to dress wheels up to 24" in diameter.

PLEASE REFER TO SPECIFICATIONS ON PAGE

THESE ARE SOME OF THE FORMS OBTAINABLE WITH

Fluidmotion®
DRESSERS

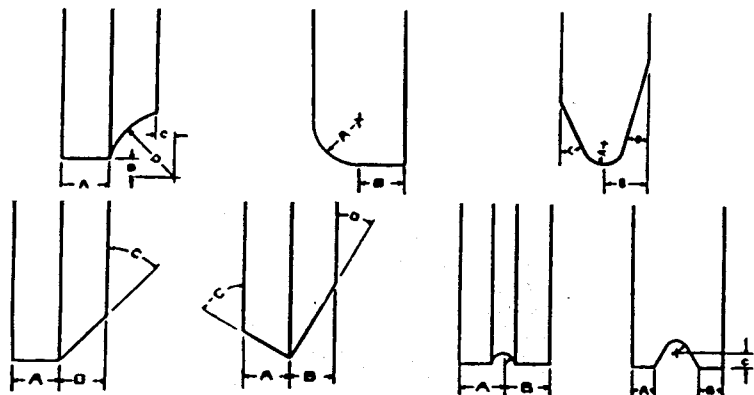

This form tangent in one setting—two angles—two radii—one flat. Concave and convex forms in one setting with flat between radii are possible with special stops on our standard "Fluidmotion" series radii and angle wheel dressers.

Angles may be different. Radii must be the same size. Length of flat is controlled by stops set on cross feed of machine table. Ask for prices on special stops before purchasing a Fluidmotion wheel dresser.

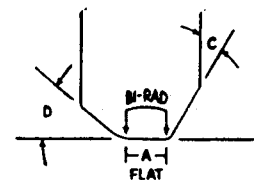

PRECISE SHARP CONTOURS—concave or convex, at a full 180 degrees, are obtained consistently with (GUARANTEED) 0.0001" accuracy.

CONVEX RANGE—zero to 3 inches.

CONCAVE RANGE— $1/32$ " to $3\frac{1}{2}$ inches.

Special dressing equipment can be furnished to dress wheels up to 24" in diameter. Dresser swivels on Stainless Steel Ball Bearings which are **completely protected from dust**.

Accurate . . . Fluidmotion . . . Precise . . .

HOLD INTERSECTING ANGLES 12 to 15 seconds. THIS is done by upright and handle. Setting up two angles requires 10 seconds. Setting two angles and radius requires less than 3 minutes.

DURABLE—EXTRA LONG LIFE

7000 **FLUIDMOTION** radii and Angle wheel dressers sold—less than 1% returned for servicing—**NONE** returned for wear.

BECAUSE

1. Only the finest **HIGH-CARBON, HIGH-CHROME**, hardened, ground and lapped alloy steels, highly resistant to abrasive action, are used.
2. No wearing surfaces. Swivels on stainless steel ball bearings completely protected from dust.

Fluidmotion WHEEL DRESSERS — OPERATING INSTRUCTIONS



THE ONLY TOOL REQUIRED FOR SETTING IS A MICROMETER

1. Obtain micrometer reading over diamond as in photo "A". Assume it to be 2.531
2. ADD desired convex radius. Assume it to be + .069
3. Loosen gib and set total reading over lower "mike" pins photo "B" (use micrometer). 2.600
4. Tighten gib and you're ready for action photo "C".

1. Obtain micrometer reading over diamond as in photo "A". Assume it to be 2.900
2. SUBTRACT desired concave radius. Assume it to be -2.142
3. Loosen gib and set difference over lower "mike" pins photo "B" (use micrometer). .748
4. Tighten gib and you're ready for action photo "C".

1. Obtain micrometer reading over diamond as in photo "A". Assume it to be 2.000
2. Loosen gib and set same reading over lower "mike" pins photo "B" 2.000
3. Tighten gib and you're ready for action photo "C". This will be dead center or 0.000 radius

1. Loosen knurled knob at rear of swivel base.
2. Grip the two ring pins and set desired angle by reading vernier at rear of swivel base.
3. Tighten knurled knob to lock pins at desired angle and you're ready for action.

1. Loosen knurled knob at rear of swivel base.
2. Grip the two ring pins and move together until desired vernier reading for lower pins is obtained.
3. Swivel dresser upright in opposite direction until desired vernier reading for upper pin is obtained.
4. Tighten knurled knob to lock pins in preset position for two angles and you're ready for action.
5. When setting for two angles set lower ring first. It is prelocked and will maintain set position.

To dress two angles tangent to a convex radius in one continuous motion proceed as follows:

Complete desired setting I and V. The ring pins will now be locked in desired positions and they become the tangent points where the angle joins the radius. Swing the upright against one stop and activate the angle dressing handle in the direction the diamond is to go and then return to center position. Swing around the radius to the other stop and activate the angle dressing handle for the other angle. Repeat until full form is dressed with the diamond, then spark out and form has been completed. The dressers are designed for repetitive accuracy as long as the diamond comes into contact with the full form each time the wheel is dressed.

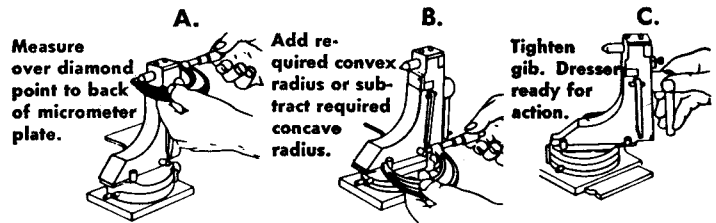

Model	Concave Radius Min & Max	Convex Radius Min & Max	Max. Wheel Dia	Length of Angular Travel	Fixed Height of Dia above Table	Adjustable Height Series	Base Dimensions	Net Weight Approx. Lbs.	Shipping Wgt Approx. Lbs.	Standard Equipment Includes			
										Dresser	Micro Base 1-1/8" Travel	Routing Die Approx. 1/3 Ct.	Instrument Carrying Case
F-50	1/32" to 1-1/2"	0" to 1-1/2"	7"	1-1/4"	5"		3-3/16" x 4"	8	12	x		x	x
F-55	1/32" to 1-1/2"	0" to 1-1/2"	8"	1-1/4"	5-1/2"		3-3/16" x 4"	8	12	x		x	x
F-618	1/32" to 1-1/2"	0" to 1-1/2"	12"	1-1/2"	6-1/8"		3-3/16" x 4"	8	12	x		x	x
F-650A	1/32" to 1-1/2"	0" to 1-1/2"	12"	2" at Max Height		4" Min to 7-1/2" Max	3-3/16" x 4"	7	13	x		x	x
F-750A	1/32" to 1-1/2"	0" to 1-1/2"	14"	2" at Max Height		4" Min to 7-1/2" Max	3-3/16" x 4"	7	13	x		x	x
RFG-50	1/32" to 1-1/2"	0" to 1-1/2"	7"	1-1/4"	6-1/8"		3-5/8" x 4-3/4"	13	17	x	x	x	x
RFG-55	1/32" to 1-1/2"	0" to 1-1/2"	8"	1-1/4"	6-5/8"		3-5/8" x 4-3/4"	13	17	x	x	x	x
RFG-618	1/32" to 1-1/2"	0" to 1-1/2"	12"	1-1/2"	7-1/4"		3-5/8" x 4-3/4"	13	17	x	x	x	x
RFG-650A	1/32" to 1-1/2"	0" to 1-1/2"	12"	2" at Max Height		5-1/2" Min to 8-1/2" Max	3-5/8" x 4-3/4"	13	17	x	x	x	x
RFG-750A	1/32" to 1-1/2"	0" to 1-1/2"	14"	2" at Max Height		5-1/2" Min to 8-1/2" Max	3-5/8" x 4-3/4"	13	17	x	x	x	x
E-75	1/32" to 3"	0" to 3"	12"	2-1/4"	7-1/2"		4" x 5"	15	20	x		x	x
E-85	1/32" to 3"	0" to 3"	14"	2-1/2"	8-1/2"		4" x 5"	15	20	x		x	x
REC-75	1/32" to 3"	0" to 3"	12"	2-1/4"	8-5/8"		4-1/2" x 6"	20	28	x	x	x	x
REC-85	1/32" to 3"	0" to 3"	14"	2-1/2"	9"		4-1/2" x 6"	20	28	x	x	x	x
H-24A	1/32" to 3"	0" to 3"	24"	4-1/4" at Max Height		6" Min to 10" Max	4" x 5"	20	33	x		x	x
RHC-24A	1/32" to 3"	0" to 3"	24"	4-1/4" at Max Height		7" Min to 11" Max	4-1/2" x 6"	27	38	x	x	x	x
WGF-50	1/32" to 1-1/2"	0" to 1-1/2"	7"	1-1/4"	5"		3-3/16" x 4"			x		x	** x
WGF-55	1/32" to 1-1/2"	0" to 1-1/2"	8"	1-1/4"	5-1/2"		3-3/16" x 4"			x		x	** x
WGF-618	1/32" to 1-1/2"	0" to 1-1/2"	10"	1-1/2"	6-1/8"		3-3/16" x 4"			x		x	** x
WGF-650A	1/32" to 1-1/2"	0" to 1-1/2"	12"	2"		4" Min to 7-1/2"	3-3/16" x 4"			x		x	** x

Concave Radii limitation determined by special diamond point (approx. .010" min. concave radius can be obtained). With our 180° Concave Radii Attachment, .045" concave radii is limited by diameter of altered steel shank holding diamond. (Can obtain minimum concave radius of .031" by employing extreme care.)

*On full 14" diameter wheel on models E and REC, maximum convex radius is 3/8", maximum concave radius is 1/2". On 11" diameter wheel or less, full range is obtainable.

**Instrument carrying case furnished for Fluidmotion Dresser Unit only.



MODEL "F-50" — UP TO 7" WHEEL

This model is for **cylindrical, internal and bench surface grinders** with wheel diameters up to 7". It is particularly adaptable to **cylindrical grinders with spindle heights as low as 5"**. Easily inserted in J & S wheel guard mounting on surface grinders and in a "G" micrometer base.

MODEL "F-55" — UP TO 8" WHEEL

This model is for **cylindrical, internal, universal, and surface grinders** with wheel diameters up to 8". It is particularly adaptable to **cylindrical grinders with a spindle height of 5½"**. Easily inserted in J & S wheel guard mounting on surface grinders and in a "G" micrometer base.

MODEL "F-618" — UP TO 12" WHEEL

This model is for **cylindrical, internal, universal and surface grinders** with wheel diameters up to 12". It is particularly adaptable to **cylindrical grinders with a spindle height of 6½"**. Easily inserted in a "G" micrometer base or a J & S Solid Angle Ramp with micrometer lead screw.

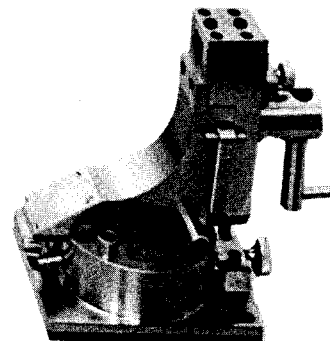

MODELS "RFG-50", "RFG-55" and "RFG-618" UP TO: 7" WHEEL 8" WHEEL 12" WHEEL

With Removable Micrometer Feed Base

This model is for **cylindrical, internal and bench surface grinders** hardened and ground alloy steel base. It is for precise grinding wheel dressing with closely controlled diamond infeed to wheel independent to table movement, having approximately 1⅜" travel.

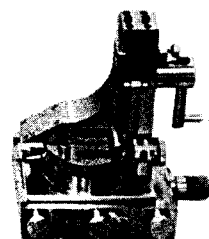

MODEL "F-650A" UP TO 12" WHEEL "F-750A" UP TO 14" WHEEL

This Dresser has adjustable diamond height of 4" to 7" above the table with two (2) holders for the diamonds. This is primarily for Universal Grinders where the Dresser needs to be mounted on a Solid Angle Ramp and both the external and internal wheels must be dressed. Price of Solid Angle Ramp extra. Other uses may also be made of this versatile unit. Actual limitations is 14" wheel diameter on "F-750A" for rigidity 12" wheel diameter is recommended as maximum on "F-650A".

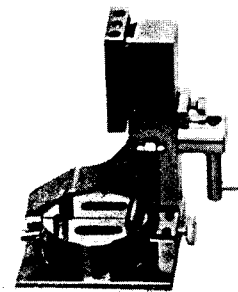

MODEL "RFG-650A" UP TO 12" WHEEL "RFG-750A" UP TO 14" WHEEL

Dresser which has the adjustable diamond height and also includes a "G" Micrometer Base for controlled infeed of the diamond. Approx. 1⅜" travel. Adjustable diamond height above table 5⅞" to 8⅞".

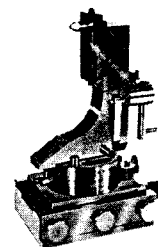

MODELS "WGF-50" 7" WHEELS, "WGF-55" 8" WHEELS

This Wheel Guard Dresser is adaptable to quills of 3" to 3½" diameter, and includes an **inverted base with compound micrometer lead screws** for maintaining position of a formed grinding wheel in relation to the work. It is **adaptable to 7" or 8" wheels**, and may be used with the present Model "F" Fluidmotion Wheel Dresser on 7" wheels.

This unit features a **spring-loaded pin** in the feed mechanism to enable the dresser to be easily removed after the dressing operation. The additional portion of the cover may be snapped in position to provide the **standard protection necessary on grinders**. A unique development in the advanced field of grinding. Available for most **surface grinders**.

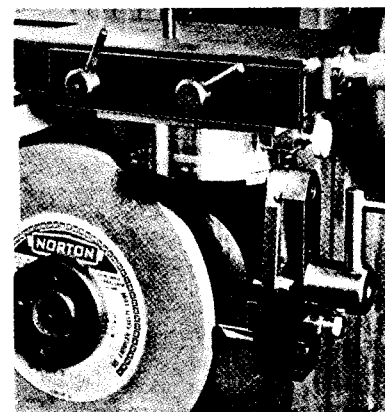

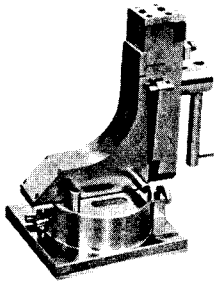

MODEL "E-75" *UP TO 14" WHEEL

This standard Model "E" Radius and Angle Dresser, greatly improved over original patented design, is now the **Finest** and **most versatile** dressing instrument procurable.

It is readily **adaptable to cylindrical grinders with up to 14" wheel diameters** by using a **J & S Solid Angle ramp with micrometer lead screw**. Has a fixed diamond height of $7\frac{1}{2}$ " above table.

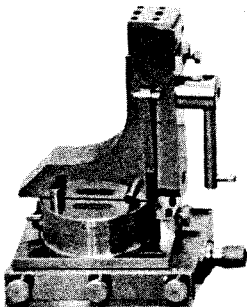

MODEL "REC-75" *UP TO 14" WHEEL

With Removable Micrometer Feed Base

This is the standard Model "E" Radius and Angle Dresser mounted on a "C" base, **hardened and ground throughout**. Designed primarily for repetitive precision production and extremely precise depth of radii, **it moves the dresser forward and backward** with a sensitive range of **approximately $1\frac{3}{16}$ "**. It is **extremely accurate** and **easy to operate**.

The "**C**" micrometer base provides the **controlled infeed** for the diamond on **surface grinders**. Has a **fixed diamond height of $8\frac{5}{8}$ "** above table.

*On full 14" diameter wheel on models E and REC, maximum convex radius is $\frac{3}{8}$ ", maximum concave radius is $1\frac{1}{2}$ ". On 11" diameter wheel or less, full range is obtainable.

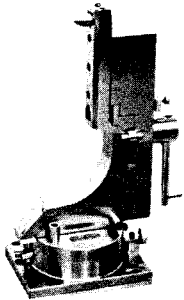

MODEL "H-24A" UP TO 24" WHEEL

The Model H24A Radius and Angle Dresser is the same fine dressing instrument as the E75. Excellent for use on cylindrical and internal grinders using wheels up to and including 24" diameter. This unit is particularly versatile because of its adjustable diamond heights and is readily adapted to internal grinders. Also widely adaptable for use on cylindrical grinders with varying center heights, table styles and wheel diameters. Very valuable for dressing fillet radii on the corners of 30" diameter wheels.

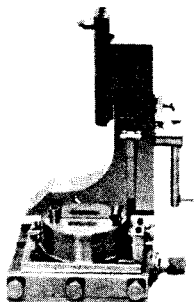

MODEL "RHC-24A" UP TO 24" WHEEL

With Removable Micrometer Feed Base

This new model was specifically designed for dressing wheels up to 24" diameter. Mounted on a "C" base, hardened and ground throughout. Excellent for repetitive precision production and extremely precise depth of radii, it moves the dresser forward and backward with a sensitive range of approximately $1\frac{3}{16}$ ".

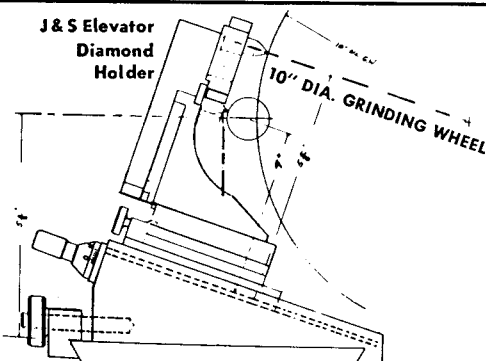

MODEL "F-650A"

With Adjustable Diamond Height and Angle Ramp applied to a Norton Universal Grinder.

Note: Applications on Cylindrical Grinders.

In most cases, "Fluidmotion" Wheel Dressers can be adapted to various types of cylindrical grinders. Since the height of the center line of wheel varies on universal or plain grinders, it is necessary to dress above center line of the wheel, but co-incident to center line (illustration above).

Also, in most cases, the wheel guard must be modified to accommodate dressing the wheel co-incident to center line. Composite forms of cylindrical grinders are available for the purpose of obtaining exacting physical dimensions in order to design proper fixtures.

J & S ENGINEERS WILL DETERMINE THE PRACTICALITY OF ALL APPLICATIONS.

ATTACHMENTS FOR DRESSING

NEW MODEL

J & S Model "E" Dresser with Solid Angle Ramp and sensitive Micrometer Lead Screw applied to typical cylindrical grinder with flat table. Composite forms of cylindrical grinders are available for the purpose of obtaining exacting physical dimensions in order to design proper fixtures. J & S ENGINEERS WILL DETERMINE THE PRACTICALITY OF ALL APPLICATIONS.

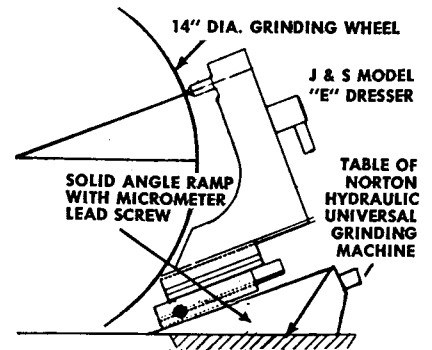

When it is not practical to dress on the side of the wheel this method may be used for dressing wheels up to 24" diameter with a Model "H24A" dresser.

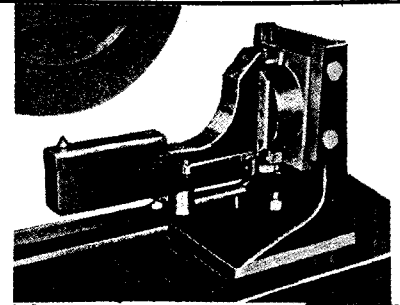

This useful attachment can be used with either the Fluidmotion or the Form Master Wheel Dressers. With it, U-shaped radii can be formed. The attachment includes three diamonds for 1/16", 3/32", and 1/8" minimum radii. Also available for the Fluidmotion Dressers only, and requiring extreme care and skill in use, is a diamond for 3/64" minimum radii.

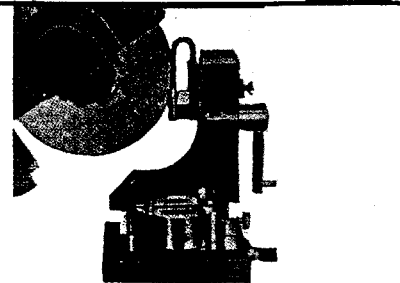

Wheel dresser shown with form checker attachment for checking and obtaining a true profile.

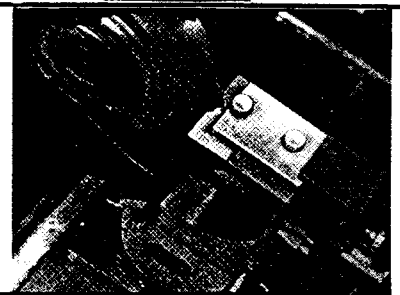

CLAMP

This clamp is especially designed to hold Fluidmotion Radii and Angle Dressers firmly and squarely to flat cylindrical grinder tables. Then, by simply tightening or loosening one set screw in gib, the Dresser is easily located or removed from clamp which remains affixed to grinder table.

*Note: Factory will recommend proper equipment and fixtures.

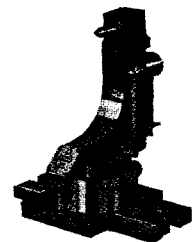

STRAIGHT CHAMFERING

Break or chamfer corners with a single pass, rapid operation, minimum equipment, and positive results. Mounts on the same guard as the new Wheel Guard Dresser. Screw adjustment minutely exposes the wheel at a 45° angle through the guide.

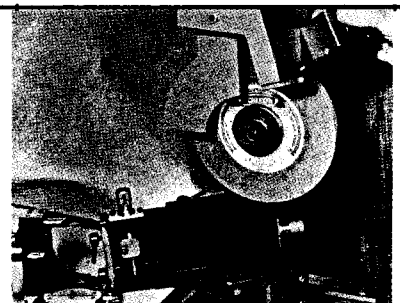

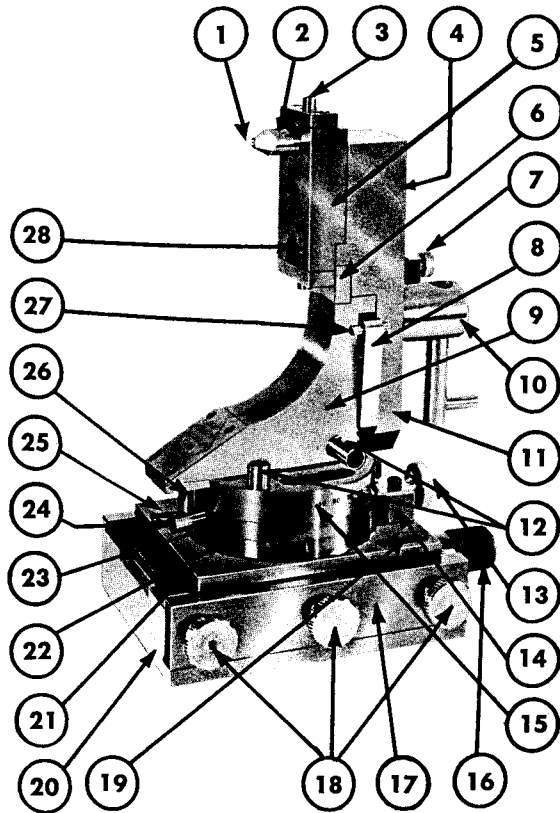

- | | |
|---|--|
| 1. Diamond | 14. Vernier plate |
| 2. Diamond shank | 15. Swivel base |
| 3. Diamond shank locking screw | 16. Micrometer base lead screw knob |
| 4. Micrometer plate (or surface) | 17. Micrometer base spring loaded gib |
| 5. Adjustable diamond holder | 18. Knurled gib tension setting screws |
| 6. Spring loaded drag plate | 19. Serial No. marking |
| 7. Angle traverse locking screw | 20. Micrometer base |
| 8. Centering arms | 21. Dresser base |
| 9. Dresser housing | 22. Lower swivel ring |
| 10. Angle traverse control handle | 23. Upper swivel ring |
| 11. Dresser upright | 24. Upper swivel ring stop pin |
| 12. Micrometer pins | 25. Lower swivel ring stop pin |
| 13. Upper & lower swivel ring locking screw | 26. Swivel base stop pin |
| | 27. Centering arm locating pin |
| | 28. Secondary diamond holder |

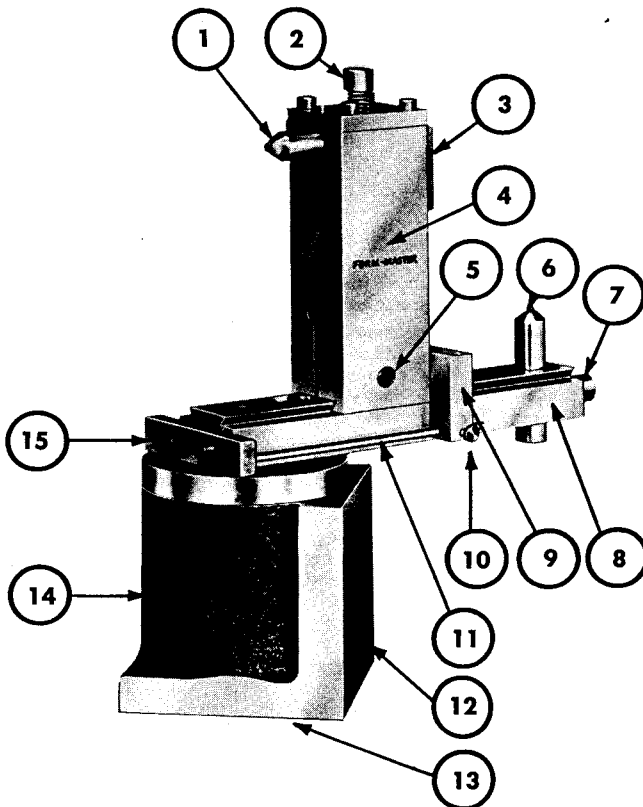

- | |
|---|
| 1. Diamond (for radius dressing) |
| 2. Diamond locking screw |
| 3. Micrometer plate |
| 4. Radius dressing upright |
| 5. Radius upright locking screw |
| 6. Diamond (for angular dressing) |
| 7. Diamond locking screw |
| 8. Radial arm or angular dressing upright |
| 9. Rear micrometer setting block |
| 10. Setting bar locking screw |
| 11. Setting bar |
| 12. Bottom surface for angular dressing |
| 13. Bottom surface for radius dressing |
| 14. Dresser base |
| 15. Forward micrometer setting block |

FORM-MASTER SERIES

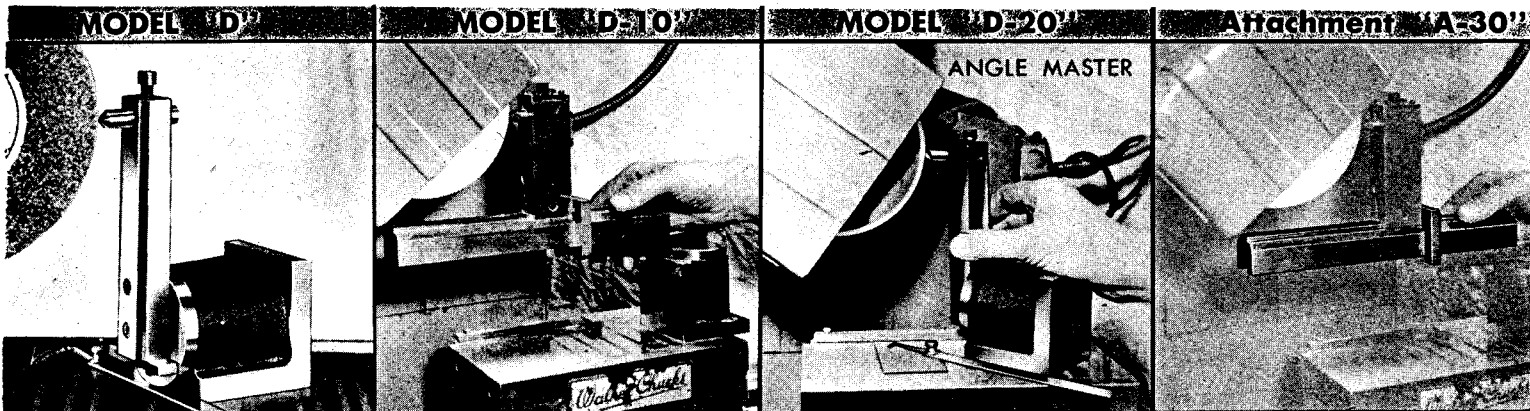

MODEL "D" DRESSER set up to dress angles—see below for set up to dress radii.

Same specifications as for Model "D" except for increasing range of convex radii to 12" and concave radii to 15."

This is an inexpensive Dresser for dressing Grinding Wheels up to 7" in diameter.

This Attachment is for use with the J & S MODEL "D" FORM MASTER to increase its range to 12" convex radii and 15" concave radii.

SPECIFICATIONS

Concave Radii Range to 7" on 7" Dia. Wheel; Convex Radii Range to 4" on 7" Dia. Wheel. .001 Tolerance—10" Diameter Wheel—3"x3" Base. Weight 12 lbs—Diamond Point 7-3/4" above Table.

Note: Range of Radii decreases as wheel diameter increases—on 10" Wheel convex Radius of 1" is obtainable.

The FORM MASTER SERIES is a sturdily designed, High Quality, Low Cost Angle or Radius Dresser with sealed in ball bearings. Cast Iron Base insures drilling and tapping of holes to adapt to most grinders.

OPERATING INSTRUCTIONS TO OBTAIN

1. **CONVEX RADII** . . . Adjust height of grinding wheel spindle to bring center line of diamond (1) on a line horizontal with the centerline of the wheel. With a micrometer measure over point of diamond to back of micrometer plate (2). This is a reference dimension only (preferably about 2.500") and **there is no need to preset the diamond to a constant dimension.** Add 1.000 to this reading and add the desired convex radius. The resulting figure is the reading to be made with a micrometer over the face of the front micrometer plate (3) to the back of the rear micrometer plate (4). To obtain this reading, loosen the upright clamping screw and move the upright along the angle bar until the micrometer plates are in the position which gives the micrometer reading desired. This places the diamond in **back** of the pivot centerline by the amount of the required convex radius.

For Example:

A. Reference measurement over point of diamond to back of micrometer block	2.600"
B. Add 1.000"	+ 1.000"
	3.600"
C. Add .750 required convex radius	+ .750"
	4.350"

2. **CONCAVE RADII** . . . Place diamond centerline coincident with centerline of wheel as noted above. Follow same procedure as for convex radii, except **subtract** desired radius from lower micrometer plate measurement. That is, measure over point of diamond micrometer plate for reference dimension. **Add 1.000"** to this measurement and then **subtract** the desired concave radius. Loosen upright clamping screw and move upright to obtain the resulting reading with a micrometer over the face of the front micrometer plate to the back of the rear micrometer plate. This places the diamond in **front** of the pivot centerline by the amount of the required concave radius.

For Example:

E. Reference measurement over point of diamond to back of micrometer block	2.475"
F. Add 1.000	+ 1.000"
	3.475"
G. Subtract .375" required concave radius	- .375"
	3.100"

3. **ANGLES** . . . Place diamond centerline coincident with horizontal centerline of wheel as instructed before. Remove upright which is used for dressing radii and set Form-Master on angle base 90° from base used for radii. Set dresser to desired angle with sine-bar or protractor used in conjunction with backing plate on magnetic chuck.

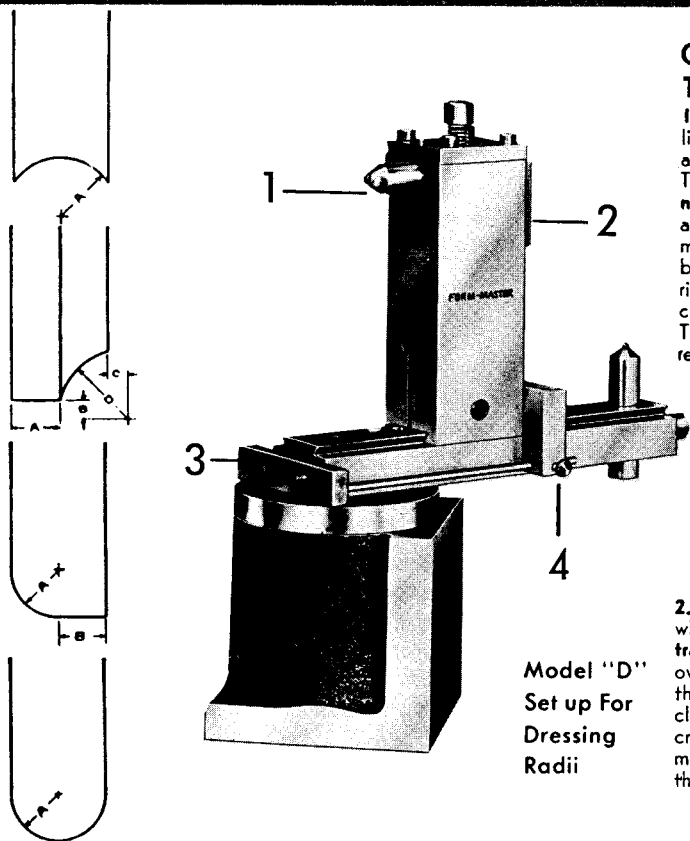

Model "D"
Set up For
Dressing
Radii

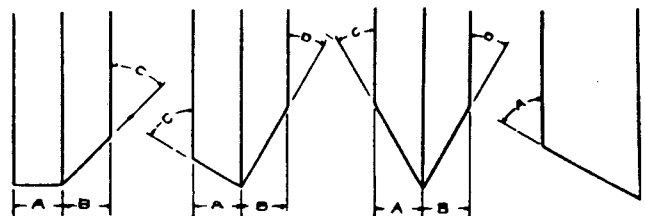

for CYLINDRICAL and SURFACE GRINDERS

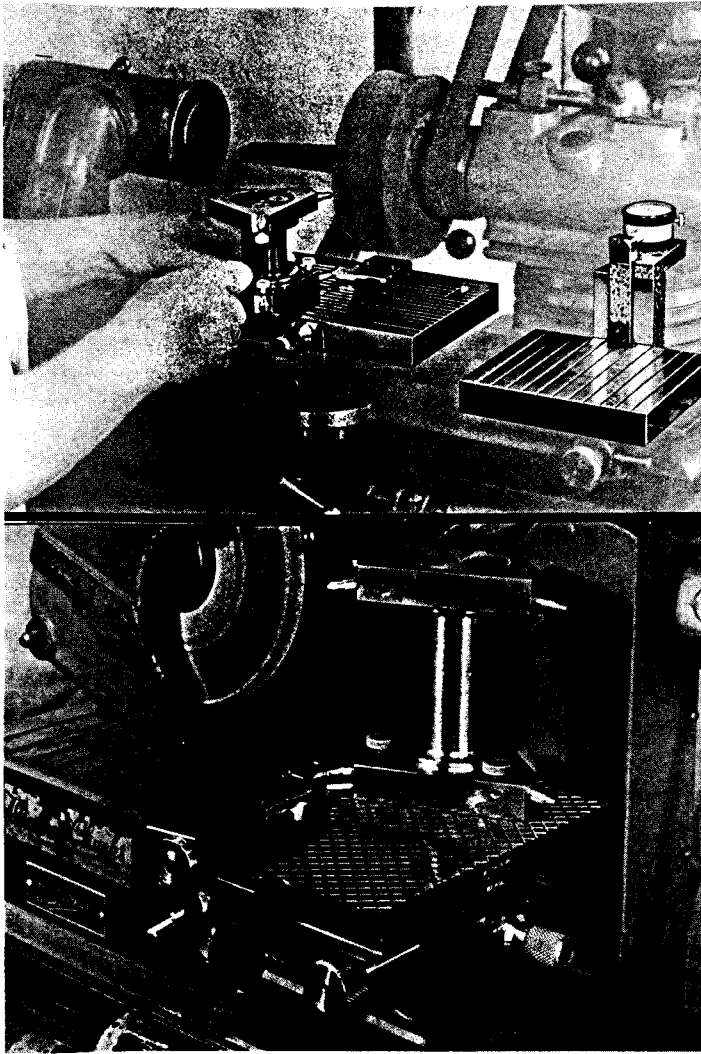

Forms may be dressed and readily held to template contour. By using the J & S CONTOUR DRESSER your operators are able to dress most all generated forms required by today's complicated tools.

Stylist Contour Checker is used to check squareness and contour of stylist and diamond point. Also for setting driving arm to correct position.

The form on the diamond point is quickly duplicated on the stylist by inverting Dresser and correcting stylist against grinding wheel. Micrometer feed control on base, feeds diamond into grinding wheel for dressing. Positive rigid feed control enables operator to traverse the stylist over template contour with controlled ease and accuracy.

Traversing of stylist over template is done from fulcrum point of the stylist and diamond. This eliminates uneven feed and loss of control when stylist travels over sharp sudden changes in direction of the template form.

FEATURES

- Simple inexpensive dressing of complicated forms.
- Unique simplicity of set-up and operation.
- Use two diamonds. One for roughing, one for finishing.
- Repetitive dressing without removing work piece on surface grinder.
- Low Diamond cost.
- Readily mounted on Cylindrical and Surface Grinders.

SOME OF THE MANY GENERATED FORMS OBTAINABLE WITH THE

CONTOUR DRESSER

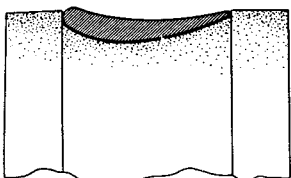

GIULLOTINE GAGE

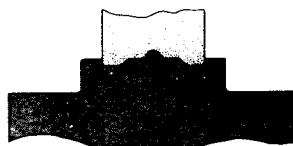

FORM ROLLS

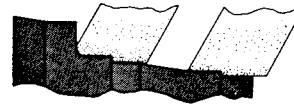

SPINDLES

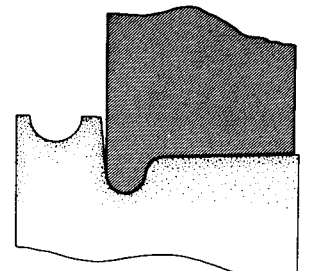

R.R. LOCOMOTIVE TIRES

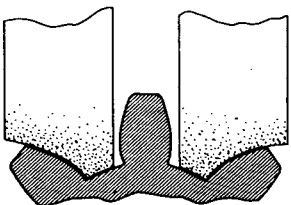

GEARS AND SPLINES

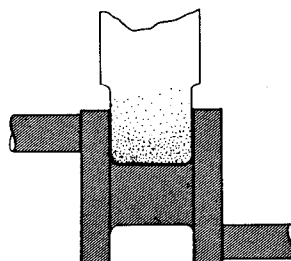

CRANKSHAFTS

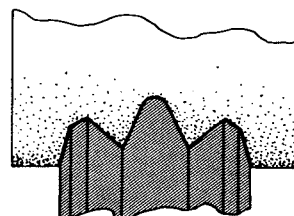

WORM GEARS

FOR SURFACE GRINDERS

WITH UP TO 14" DIAMETER GRINDING WHEELS AND MAXIMUM OF 1" DEPTH OF FORM. LARGER DIAMETER WHEELS AND DEPTH OF FORM ON REQUEST.

1406
works

585.00

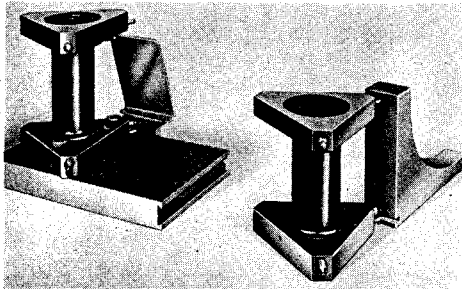

This is our economy J & S "Contour Dresser" for dressing most all generated forms on surface grinders. For use on magnetic chuck. Requires removing "Dresser" and "Template Base" on some dressing operations. For smooth and controlled dressing and if form has sudden changes in direction, the "Feed Control" attachment should be used. (See Model No. S-9)

900.00

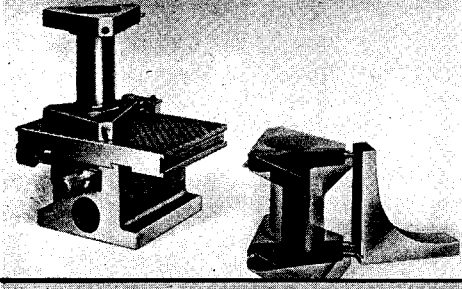

Same as S-5 above except with the addition of the "Adapter Base" with Lead Screw. With this Model the operator does not have to remove the "Dresser" and "Template Base" between dressing operations. Equipment stays on grinding machine at all times. For smooth and controlled dressing and if form has sudden changes in direction, the "Feed Control" attachment should be used. (See Model No. S-9)

1051.00

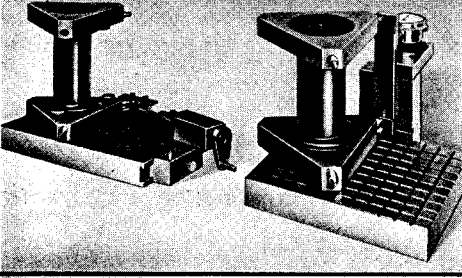

For precise dressing of generated forms. In this group we have added the "Stylist Contour Checker" and "Feed Control" which enables the operator to control accuracy to a much greater degree. For use on magnetic chuck. Requires removing "Dresser" and "Template Base" on some dressing operations.

1298.00

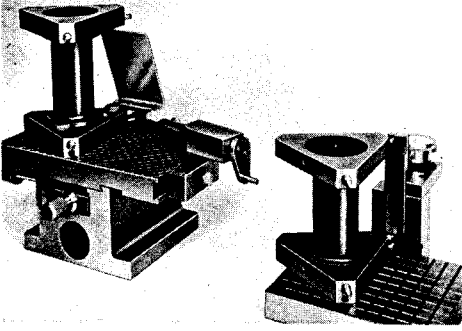

Same as S-9 above except with the addition of the "Adapter Base" with Micrometer Lead Screw. The operator does not have to move the "Dresser" and "Template Base" between dressing operations. Equipment stays on grinding machine at all times.

FOR CYLINDRICAL GRINDERS

627.00

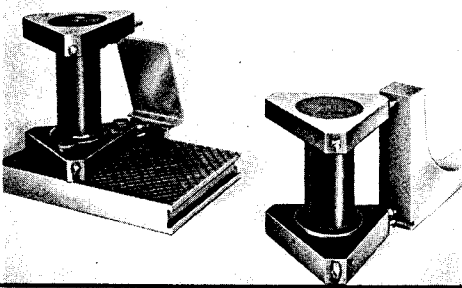

This is our economy J & S "Contour Dresser" for dressing most all generated forms on cylindrical grinders up to 14" diameter Grinding Wheels with a minimum work center height of 5 1/2" and with 1" total depth of form. May require special base (at additional cost) to adapt this equipment to your particular cylindrical grinder. Specify type cylindrical grinder and factory engineers will make recommendations.

1147.00

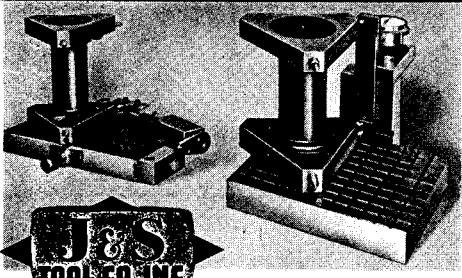

Same as C-5 above except with the addition of the "Stylist Contour Checker" and "Feed Control" which enables the operator to control accuracy to a much greater degree. Requires special base (at additional cost) to adapt this equipment to your particular cylindrical grinder. Specify type cylindrical grinder and factory engineers will make recommendations.

OPERATION INSTRUCTIONS

OPERATING INSTRUCTIONS — CONTOUR DRESSER FOR MODELS S-9, S-11, and C-9

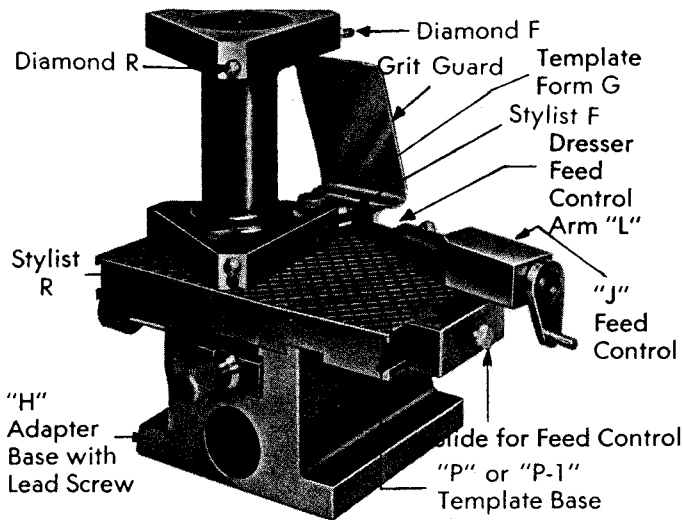

- Two (2) surfaces "A" which are ground square and concentric to top and bottom surfaces of Dresser B-14 are brought into contact with bottom and top carbide faces of Stylist Contour Checker, "C". Set indicator "D" of dial to "Zero". This is your master setting.
- Now, bring Stylist "F" and Diamond "F" into contact with Carbide faces and adjust Diamond "F" in or out thru hole "E" in order to get a zero reading and to bring Diamond Point "F" directly over Stylist Point "F".
- To correct the form on Stylist Point "F", invert Dresser B-14 and set on "Template Base" "P" or "P-1" so Diamond Point "F" Contacts any section on template form "G". Now feed Stylist Point "F" into grinding wheel by use of lead screw on "Adapter Base" "H" or Grinding machine infeed and oscillate the Dresser with Diamond Point "F" on template so as to grind the same form on Stylist "F" as appears on the Diamond Point "F", limiting the movement to about 15° on each side. This will give about 150° included angle on the Stylist point. Which is adequate for most dressings.
- Re-check Stylist "F" to assure a zero reading on dial indicator "D". This assures Diamond Point "F" to be directly over Stylist Point "F" and also that the two points have the same contour.
- When dressing wheel always be sure to use grit guard and occasionally brush base free of grit.
- Now, providing the "Dresser" B-14 is equipped with a "Feed Control" "J" you set fulcrum point of "Dresser Feed Control Arm" "L". This is done by loosening screw and allowing the pivot on the "Dresser Feed Control Arm" "L" to contact its gaging surface in the Groove "K" at the bottom of the Master Square "Z" or Stylist Contour Checker "C" upright. This provides the proper fulcrum point which enables the operator to rotate on the periphery of the Stylist Point when traversing over the Template Form "G".
- The "Feed Control" "J" is an easy and sure way to control the feed of the Dresser Stylist Point across the template form. Set Feed Control Slide so Feed Control "J" is in the best general position for feeding across your particular template form. The Feed Control is especially helpful where the form on the template has sharp changes in direction.

ROUGHING FORM ON GRINDING WHEEL

- Diamond "R" and Stylist "R" are used for roughing operations before finishing with Diamond "F" and Stylist "F".
- Retract Diamond "R" or advance Stylist "R" the required amount you wish to leave on the work piece for a final finishing grind, from the "Zero" setting on the stylist contour checker.

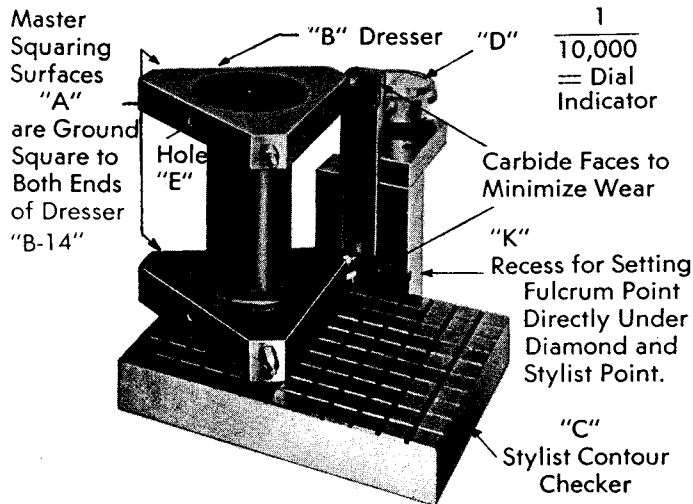

DRESSER ASSORTMENT

- A. REC75
- B. RHC24A
- C. & G. S11 CONTOUR
- D. SPECIAL H36A & S. A. R.
- E. MODEL "D" FORMASTER
- F. MODEL F650A
- H. RFG50
- I. F50

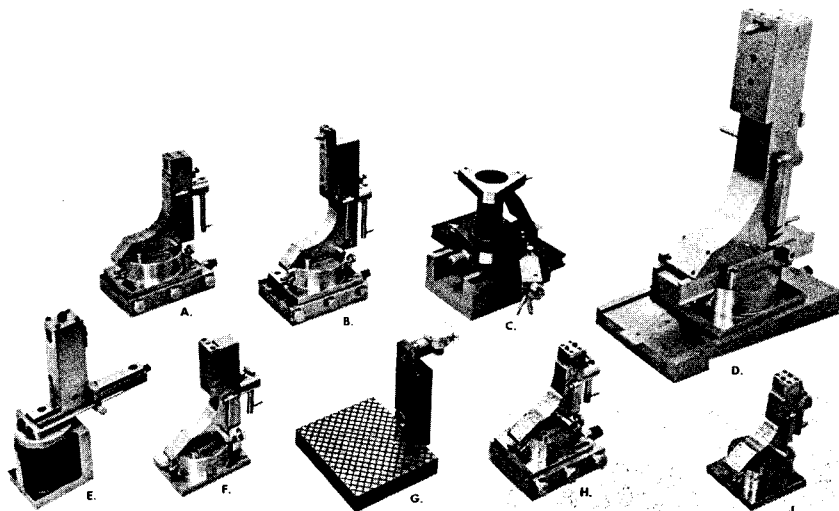

OTHER J&S "QUALITY CONTROLLED" PRODUCTS

IT'S THE BEST WHEN IT'S MADE BY

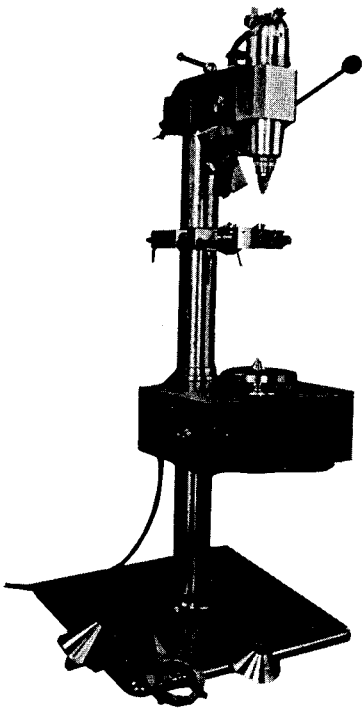

VERTICAL
CENTER
HOLE
GRINDER

MODEL - L2—HORIZONTAL (DOUBLE END SIMULTANEOUSLY)

Small Center Hole Grinder

Quick double end center hole grinding is readily accomplished on this two spindle compact machine. Capacity 7" long under 1 lb. in weight. Independent spindles rheostat controlled. Grinds two center holes true in a matter of seconds.

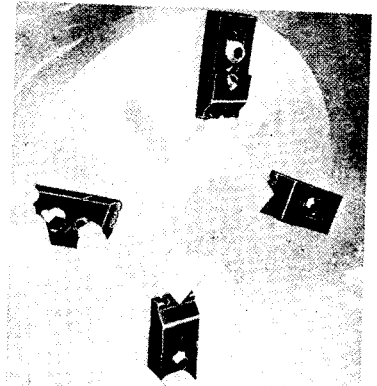
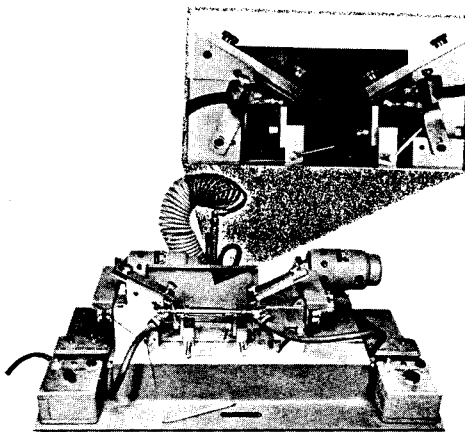

Typical lathe application. Standard clamp in use. Eliminates "U" clamps, straps and fingers.

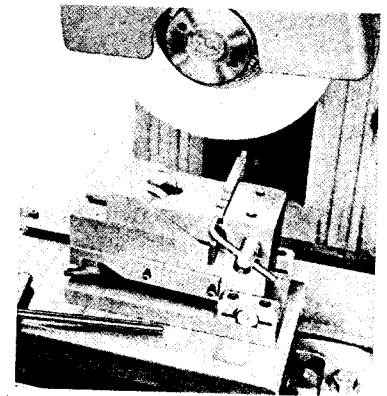

Precision Grinding Vise with or without sine bar allows rapid unloading and exact relocating.

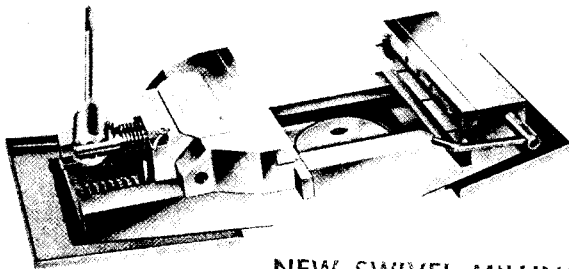

NEW SWIVEL MILLING VISE

Down Holding
No Hammering
Trigger Opening & Closing
Opens to 13"
Mounts Low

10" x 12" Vise Shown Here

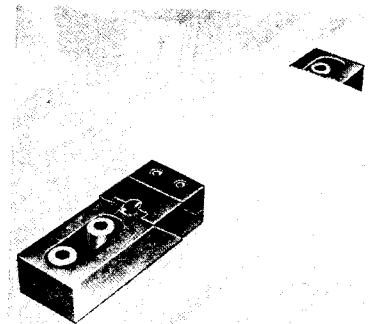

New larger "Jumbo" and "Li'l-Giant" clamps for use on large-type planers.

DISTRIBUTED BY:

PARTS — SALES — SERVICE
RICE MACHINERY, INC.

(Reynolds of Baker Street)

1104 Pontiac Ave. • Cranston, R. I. 02920

Telephone 401-781-3010