

M-122

**QUICK CHANGE TOOLING
AND ACCESSORIES**

for the

J head

and

2J variable speed head

(Available Only Through Your Bridgeport Dealer)

Bridgeport **TEXTRON**

Bridgeport Machines Division of Textron Inc.

IMPORTANT

SAFETY INFORMATION

To prevent serious bodily injury, you should observe the following basic safety precautions when installing, operating or servicing your Bridgeport milling machine.

1. Follow all instructions in the machine manual.
2. Wear approved industrial safety glasses and safety shoes.
3. **Do not** wear gloves, long sleeves, long hair, rings, watches, jewelry or other loose items that could become caught in moving parts.
4. Keep all parts of your body away from moving parts (belts, cutters, gears, etc.)
5. Use proper point of operation safeguarding.

These and other safety precautions are discussed in the American National Standards Institute Standard entitled *Safety Requirements for the Construction, Care, and Use of Drilling, Milling, and Boring Machines* (ANSI B11.8-1974).

This publication is available from: The American National Standards Institute
1430 Broadway
New York, New York 10018

Safeguarding for protection at the point of operation can only be designed and constructed when the parameters of the particular operation have been determined. As a result, ANSI B11.8-1974, Section 5.1, states that *"it shall be the responsibility of the employer to provide, and ensure the use of, a guard, guarding device, awareness barrier, awareness device, or shield..."*.

To assist machine users in designing point of operation safeguarding for their specific machine applications, the Occupational Safety and Health Administration has published a booklet entitled *Concepts and Techniques of Machine Safeguarding* (O.S.H.A. Publication Number 3067).

This publication is available from: The Publication Office — O.S.H.A.
U.S. Department of Labor
200 Constitution Avenue, NW
Washington, D.C. 20210

M-122A

QUICK CHANGE TOOLING
AND ACCESSORIES
FOR THE
J HEAD
AND
2J VARIABLE SPEED HEAD

THIS MANUAL PROVIDES INFORMATION WHICH IS PROPRIETARY TO BRIDGEPORT MACHINES AND IS MADE AVAILABLE TO YOU FOR THE USE AND MAINTENANCE OF OUR PRODUCTS. ANY USE, REPRODUCTION, OR DISSEMINATION OF THIS INFORMATION FOR ANY OTHER PURPOSE IS PROHIBITED WITHOUT WRITTEN PERMISSION.

MAY, 1981

Bridgeport® **TEXTRON**

Bridgeport Machines
Division of Textron Inc.

INDEX

#30 QUICK CHANGE TOOLING FOR THE BRIDGEPORT "J" HEAD AND "2J" VARIABLE SPEED HEAD

Model	Description	Page No.
#30	Tooling Package for J and 2J Head	i
#30	Tooling Package for Series I Numerical Control	ii
#30 QC	Bridgeport Spindle with #30 Quick Change	1
#309	Double Angle Collet Chuck - Less Collet	3
#189	Double Angle Collet Chuck - Less Collet	4
	Double Angle Collets	
#300	Collets for 1/32", 1/16" Drill	10
#300	Collet for 3/32" Drill	10
#300	Collets for 1/8" thru 1/4" drill in 1/32" Increments	10
#200	Collets for 1/8" thru 3/8" drill in 1/32" Increments	10
#100	Collets for 1/4" thru 9/16" drill in 1/32" Increments	10
#180	Collets for 1/4" thru 3/4" drill in 1/32" Increments	10
#309	Double Pin Type Floating Holder - Less Collet	7
#209	Double Pin Type Floating Holder - Less Collet	8
#075 HTG	Drill and End Mill Chuck - Less Collet	12
#100 HTG	Drill and End Mill Chuck - Less Collet	13
	End Mill Adapters	
	3/16 End Mill Shank Diameter	21
	3/8 End Mill Shank Diameter	21
	1/2 End Mill Shank Diameter	21
	5/8 End Mill Shank Diameter	21
	3/4 End Mill Shank Diameter	21
	7/8 End Mill Shank Diameter	21
	1" End Mill Shank Diameter	21
#303	Extension Chuck - Less Collet	9
#203	Extension Chuck - Less Collet	9
#103	Extension Chuck - Less Collet	9
#L09	Full Roller Drive Floating Holder - Less Collet	5
	Jacobs Taper Adapters	
#3	Jacobs External Taper	24
#4	Jacobs External Taper	24
#6	Jacobs External Taper	24
	Morse Taper Adapters	
#1	Morse Taper Socket	23
#2	Morse Taper Socket	23
#3	Morse Taper Socket	23
#180NP	Non-Pullout End Mill Collets for 3/8", 1/2", 5/8", & 3/4"	11
075 NPTG	Non-Pullout End Mill Collets 3/8", 1/2", & 5/8"	17
100 NPTG	Non-Pullout End Mill Collets 3/8", 1/2", 5/8", & 3/4"	17
100 NPTG	Non-Pullout End Mill Collets 1"	17
#30 QC	Preset Fixture	31
#30 QC	#30 Quick Change Holder with R-8 Mounting	2
"L"	Reamer Collets 15/64" thru 27/32"	6
	Shell Mill Adapters	
	.500 Pilot Diameter	22
	.750 Pilot Diameter	22
	1.000 Pilot Diameter	22
T.G.	T.G. Collet Specifications	14
	T.G. Collets in 1/64" Increments	

Model	Description	Page No.
#075	T.G. Collets 1/16" thru 3/4"	15
#100	T.G. Collets 3/32" thru 1"	16
	Tap Collets	
#D09	Tap Collets #0 thru 1/4" Hand Tap	30
#F09	Tap Collets 1/4" thru 7/8" Hand Tap	30
#F09	Tap Collets 1/16" thru 1/2" Pipe Tap	30
#G09	Tap Collets 3/4" thru 1-1/4" Pipe tap	30
	Taper Boring Bars	
#30	#30 N.M.T.B. Taper Boring Bar 1/2 to 19/32	25
#30	#30 N.M.T.B. Taper Boring Bar 9/16 to 13/16	25
#30	#30 N.M.T.B. Taper Boring Bar 3/4 to 15/16	25
#30	#30 N.M.T.B. Taper Boring Bar 55/64 to 1-15/64	25
#30	#30 N.M.T.B. Taper Boring Bar 1-11/64 - 1-47/64	25
#30	#30 N.M.T.B. Taper Boring Bar 1-23/32 to 2-17/32	25
#30	#30 N.M.T.B. Taper Boring Bar 2-15/32 to 3-21/32	25
#D09	Tension and Compression "Safe-Drive" Tap Holder - Less Collet	27
#F09	Tension and Compression "Safe-Drive" Tap Holder - Less Collet	29
#D09	Tension Type Tap Holder - Less Collet	26
#F09	Tension Type Tap Holder - Less Collet	28
#37	Tenthset Boring Bars	
	.375 Diameter x 1.50 Length	20
	.375 Diameter x 3.00 Length	20
	.375 Diameter x 5.00 Length	20
#50	Tenthset Boring Bars	
	.500 Diameter x 2.00 Length	20
	.500 Diameter x 4.00 Length	20
	.500 Diameter x 6.50 Length	20
#37	Tenthset Boring Cutters	
	.18 Minimum Bore - .56 Maximum Depth	20
	.18 Minimum Bore - .94 Maximum Depth	20
	.25 Minimum Bore - .75 Maximum Depth	20
	.25 Minimum Bore - 1.25 Maximum Depth	20
	.31 Minimum Bore - .94 Maximum Depth	20
	.31 Minimum Bore - 1.56 Maximum Depth	20
	.37 Minimum Bore - 1.12 Maximum Depth	20
	.37 Minimum Bore - 1.88 Maximum Depth	20
#50	Tenthset Boring Cutters	
	.25 Minimum Bore - .75 Maximum Depth	20
	.25 Minimum Bore - 1.25 Maximum Depth	20
	.31 Minimum Bore - .94 Maximum Depth	20
	.31 Minimum Bore - 1.56 Maximum Depth	20
	.37 Minimum Bore - 1.12 Maximum Depth	20
	.37 Minimum Bore - 1.88 Maximum Depth	20
	.44 Minimum Bore - 1.31 Maximum Depth	20
	.44 Minimum Bore - 2.18 Maximum Depth	20
	.50 Minimum Bore - 1.50 Maximum Depth	20
	.50 Minimum Bore - 2.50 Maximum Depth	20
#37	Tenthset Boring Head and Adapter	18
#50	Tenthset Boring Head and Adapter	19

BRIDGEPORT RECOMMENDED TOOLING PACKAGE FOR
STANDARD MACHINE WITH
"J" HEAD AND "2J" VARIABLE SPEED HEAD
(PACKAGE CODE #1-57-0003)

QUAN	BRIDGEPORT NO.	DESCRIPTION
1	1-57-0005	#309 Collet Chuck #30 MMT
1	1-57-0053	#300 Collet 1/8" I. D.
1	1-57-0054	#300 Collet 5/32" I. D.
1	1-57-0055	#300 Collet 3/16" I. D.
1	1-57-0056	#300 Collet 7/32" I. D.
1	1-57-0057	#300 Collet 1/4" I. D.
1	1-57-0045	#303 Tool Extension Chuck (Uses #300 Collets Above)
1	1-57-0006	#189 Collet Chuck #30 MMT
1	1-57-0120	#180 Collet 1/4" I. D.
1	1-57-0122	#180 Collet 5/16" I. D.
1	1-57-0124	#180 Collet 3/8" I. D.
1	1-57-0126	#180 Collet 7/16" I. D.
1	1-57-0128	#180 Collet 1/2" I. D.
1	1-57-0130	#180 Collet 9/16" I. D.
1	1-57-0132	#180 Collets 5/8" I. D.
1	1-57-0134	#180 Collets 11/16" I. D.
1	1-57-0136	#180 Collets 3/4" I. D.
		Non-Pullout End Mill Collets
1	1-57-0150	3/8"
1	1-57-0151	1/2"
1	1-57-0152	5/8"
1	1-57-0153	3/4"
1	1-57-0346	1" End Mill Adapter
1	1-57-0350	1/2" Pilot Shell Mill Adapter
1	1-57-0548	Open End Wrench 1 1/2"
1	1-57-0549	Open End Wrench 1 1/16"
<p>Note: 1. To order complete package, use Bridgeport #1-57-0003. 2. For additional items, order above package plus any additional items required.</p>		

**BRIDGEPORT RECOMMENDED #30 QUICK CHANGE TOOLING PACKAGE
FOR BRIDGEPORT SERIES I N/C MACHINE
(PACKAGE CODE # 1-57-0550)**

Consists of a Bridgeport #30 Quick Change basic tooling package composed of collets as listed, corresponding tool holders, a locking fixture for assembly of cutters in the holders, and wrenches.

Quantity	Bridgeport Code No.	Description
6	#1-57-0006	Drill and end mill chuck Range: 1/4 to 3/4
1	#1-57-0120	Collet 1/4"
1	#1-57-0122	Collet 5/16"
5	#1-57-0124	Collet 3/8"
1	#1-57-0126	Collet 7/16"
2	#1-57-0128	Collet 1/2"
1	#1-57-0130	Collet 9/16"
1	#1-57-0132	Collet 5/8"
1	#1-57-0134	Collet 11/16"
1	#1-57-0136	Collet 3/4"
1	#1-57-0150	Collet 3/8" (non pullout)
1	#1-57-0151	Collet 1/2" (non pullout)
1	#1-57-0152	Collet 5/8" (non pullout)
1	#1-57-0153	Collet 3/4" (non pullout)
2	#1-57-0005	Drill Chuck Range: 1/8 to 1/4
1	#1-57-0053	Collet 1/8"
1	#1-57-0054	Collet 5/32"
1	#1-57-0055	Collet 3/16"
1	#1-57-0056	Collet 7/32"
1	#1-57-0057	Collet 1/4"
1	#1-57-0548	Open End Wrench 1-1/2"
1	#1-57-0549	Open End Wrench 11/16"
1	#1-57-2335	Locking Fixture for Chucks

NOTE: to order complete package, use Bridgeport Code #1-57-0550.

1

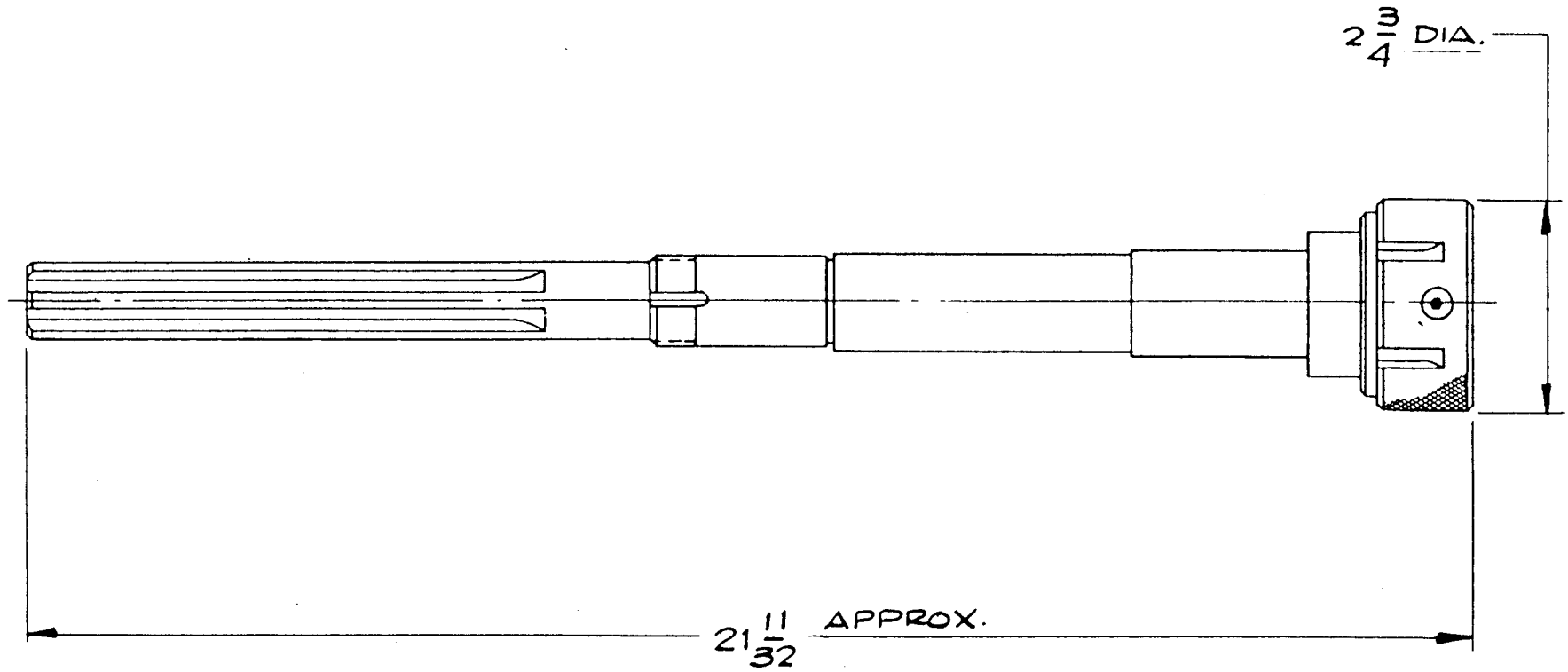

BRIDGEPORT #1-57-0000

(Includes Wrench
& Drive Keys)

#30 QUICK CHANGE SPINDLE FOR BRIDGEPORT
J HEAD & 2J VARIABLE SPEED HEAD

#30 M.M.T. SOCKET
3.500 T.P.F.

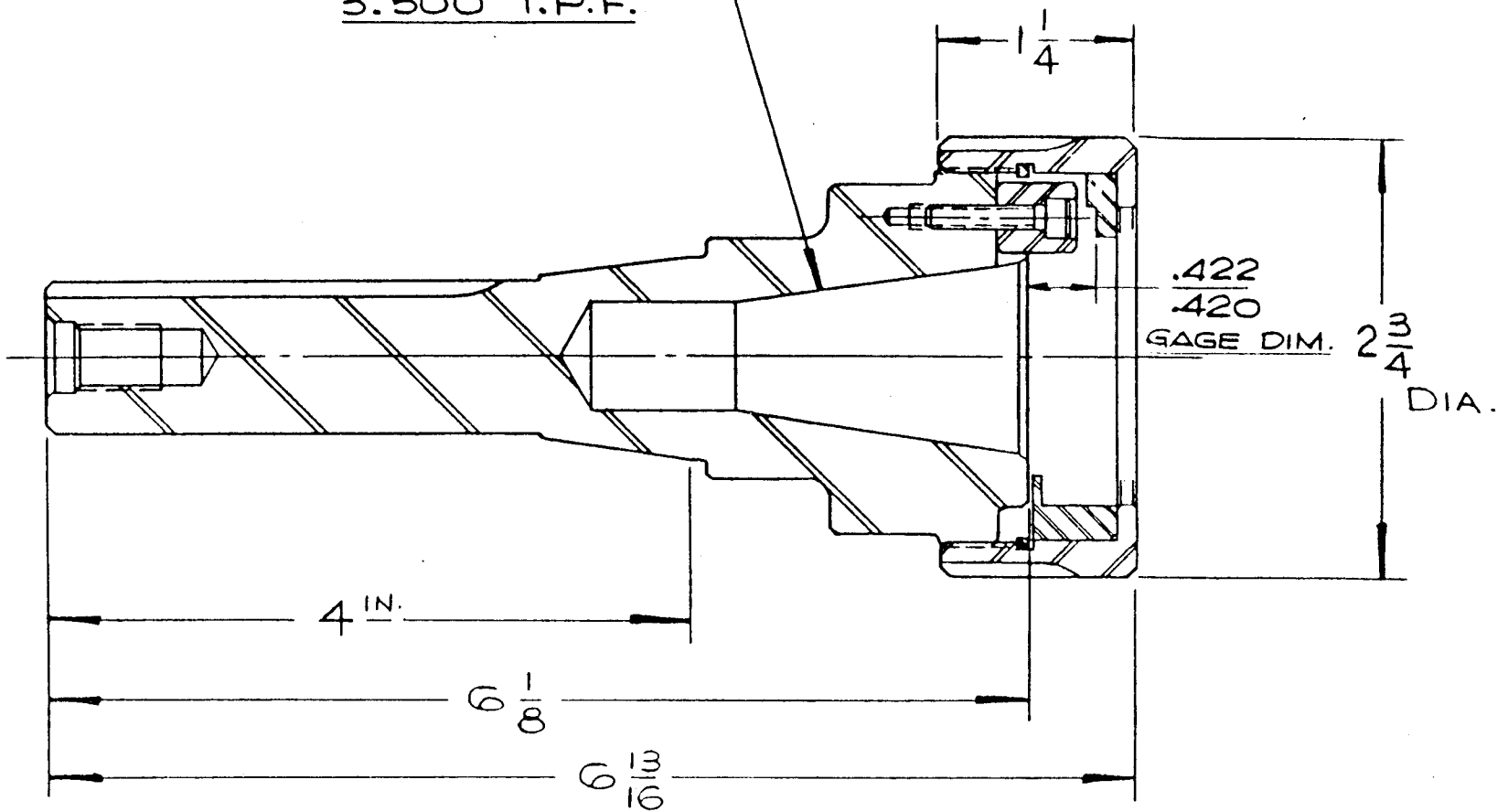

BRIDGEPORT #1-57-0001

#30 QUICK-CHANGE HOLDER
W/#R-8 MTG.

2

1/4 MAX. DIA.
THRU SHANK

1 1/2 MIN.
2 3/4 MAX.

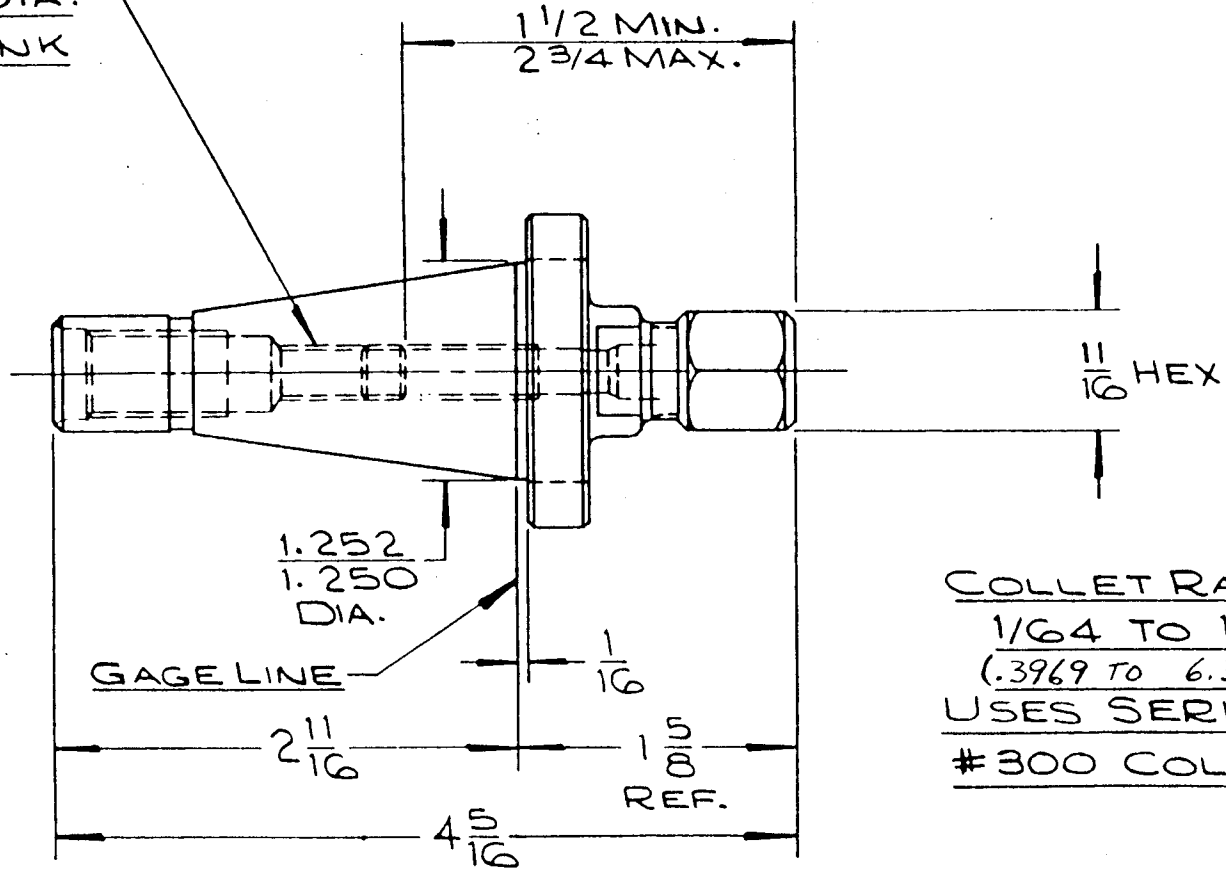

COLLET RANGE
1/64 TO 1/4 INS.
(.3969 TO 6.35 MM.)
USES SERIES
#300 COLLETS

BRIDGEPORT #1-57-0005

#309 DOUBLE ANGLE COLLET CHUCK
W/ #30 M.M.T. MTG.

3/4 MAX. DIA.
THRU SHANK

1 15/16 MIN.
2 1/4 MAX.

1 1/2 HEX

COLLET RANGE
1/4 TO 3/4 IN.
(6.35 TO 19.05 MM)

1.252
1.250
DIA.

GAGE LINE

1/16

2 11/16

2 1/16
REF.

4 3/4

USES SERIES
#180 COLLETS

BRIDGEPORT #1-57-0006

#189 DOUBLE ANGLE COLLET CHUCK
W/ #30 M.M.T. MTG.

7

COLLET RANGE :
15/64 TO 27/32 REAMER
(5.9531 TO 21.4313 MM)

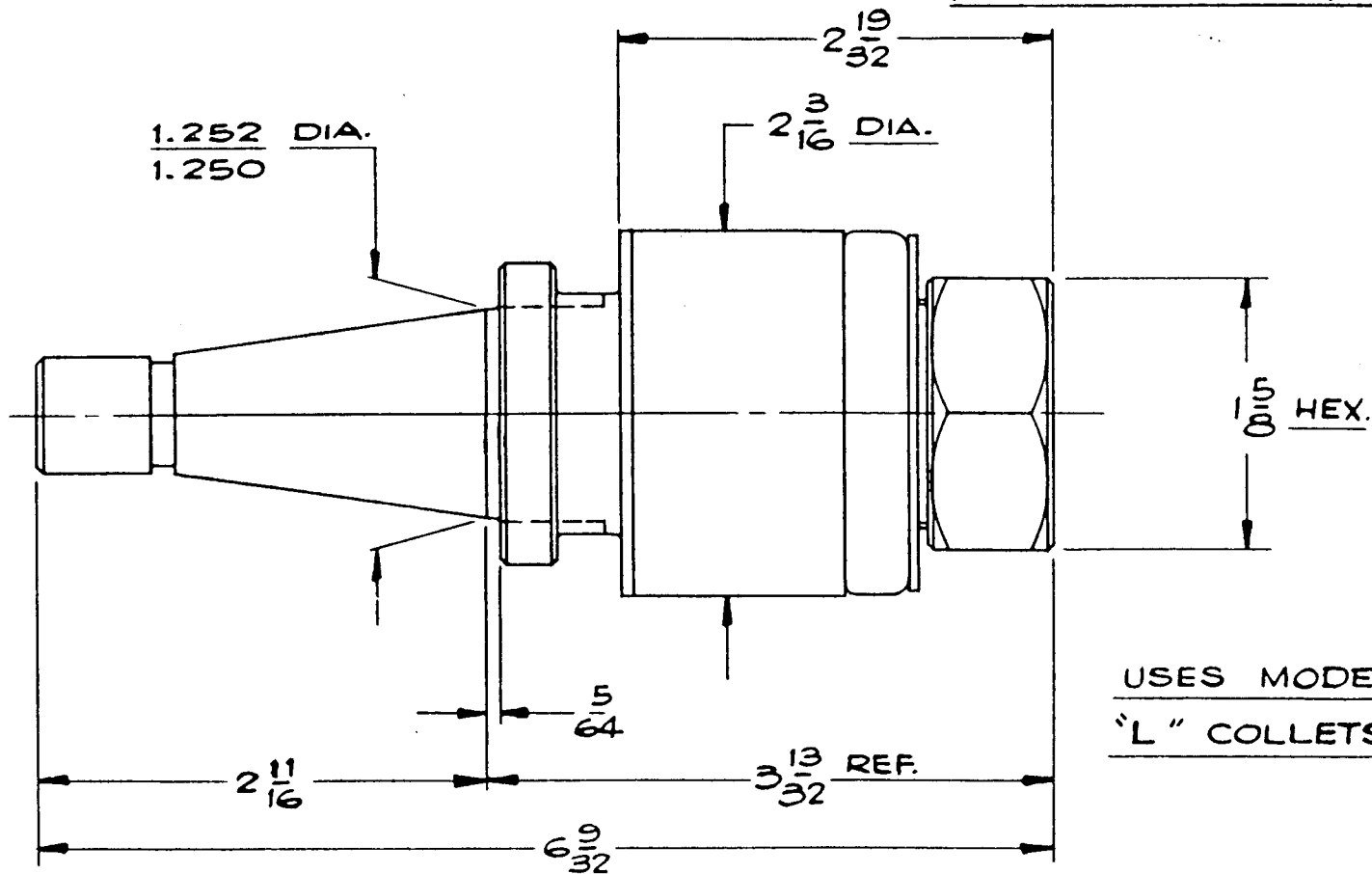

BRIDGEPORT #1-57-0010

L-09 FULL ROLLER DRIVE FLOATING
HOLDER W/ #30 N.M.T.B. MTG.

"L" REAMER COLLETS

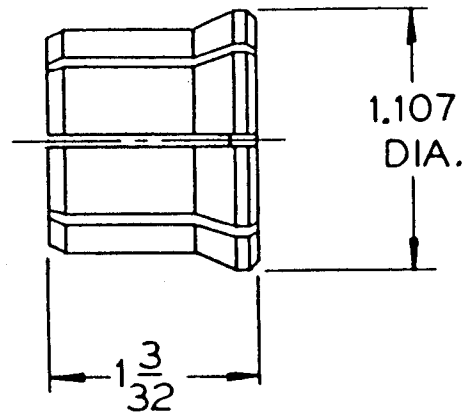

REAMER SIZE	BRIDGEPORT NUMBER	COLLET SIZE	
		INCH	MM.
15/64 & 1/4	1-57-0011	.241	6.1214
17/64 & 9/32	1-57-0012	.250	6.35
19/64 to 11/32	1-57-0013	.281	7.1374
23/64 to 13/32	1-57-0014	.312	7.9248
27/64 to 15/32	1-57-0015	.375	9.525
31/64 to 19/32	1-57-0016	.437	11.0998
5/8 to 23/32	1-57-0017	.562	14.2748
3/4 to 27/32	1-57-0018	.625	15.8750

NOTE: HOLDER HAS BOTH PARALLEL & ANGULAR FLOAT

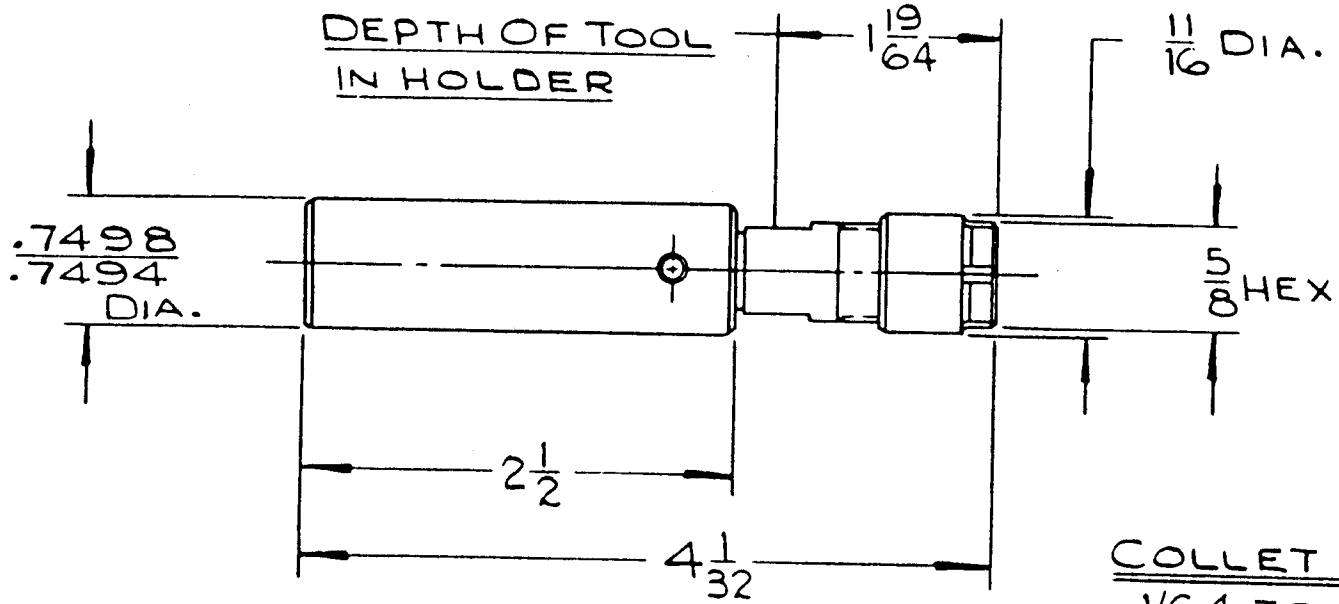

COLLET RANGE:
 $\frac{1}{64}$ TO $\frac{1}{4}$ INS.
(.3969 TO 6.35 MM)
USES SERIES
#300 COLLETS

BRIDGEPORT #1-57-0040

#309 DOUBLE PIN TYPE FLOATING HOLDER
WITH $\frac{3}{4}$ DIA. x $2\frac{1}{2}$ LG. STRAIGHT SHANK

NOTE: HOLDER HAS BOTH PARALLEL & ANGULAR FLOAT

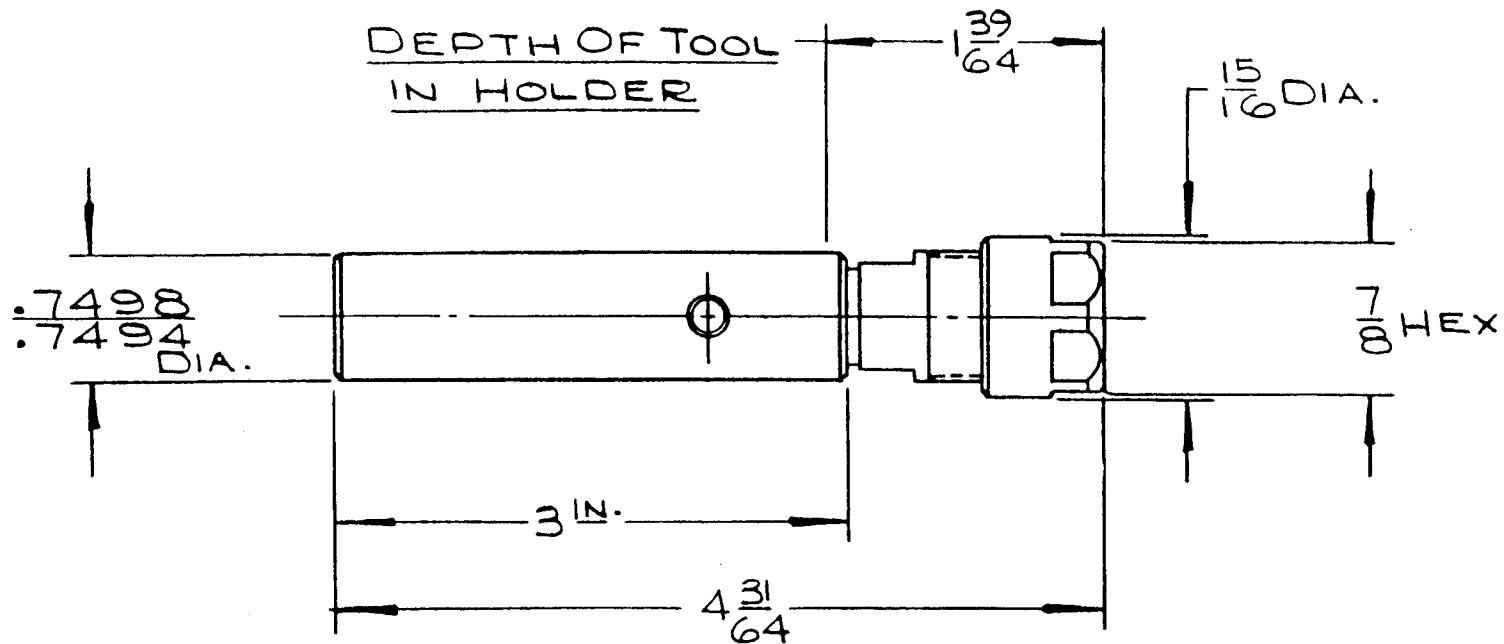

COLLET RANGE:
 $\frac{1}{64}$ TO $\frac{3}{8}$ INS.
(.3969 TO 9.525 MM)
USES SERIES
#200 COLLETS

BRIDGEPORT #1-57-0041

209 DOUBLE PIN TYPE FLOATING HOLDER
WITH $\frac{3}{4}$ DIA. X $3 \frac{1}{2}$ LG. STRAIGHT SHANK

'03 TOOL EXTENSIONS

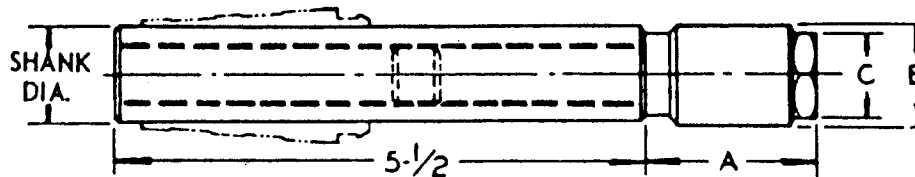

CHUCK CAPACITY		SHANK DIA.	A	B	C	COLLET SERIES	BRIDGEPORT NO.
INCH	MM						
.013-1/4	.3302-6.35	1/2	1-5/16	.560	1/2 HEX	300	1-57-0045
1/8-3/8	3.175-9.525	3/4	1-5/8	13/16	11/16 HEX	200	1-57-0046
1/8-9/16	3.175-14.2875	1 inch	1-13/16	1-1/16	7/8 HEX	100	1-57-0047

NOTE: MAX. DIA. THRU SHANK, IS SAME AS MAX. CHUCK CAPACITY.

DOUBLE ANGLE COLLETS

ALL COLLETS HAVE 1/32" COLLAPSE SO THAT A 300 COLLET 3/64" CAPACITY WILL GRIP SECURELY AND ACCURATELY A DRILL MEASURING .013 - #80.

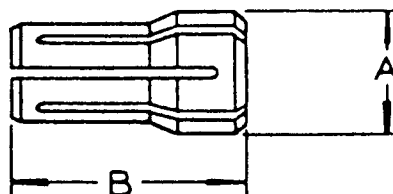

COLLET SERIES	COLLET RANGE		A	B
	INCH	MM		
300	.013-1/4	.3302-6.35	.375	1 in.
200	1/8-3/8	3.175-9.525	.539	1-3/16
100	1/4-9/16	6.35-14.2875	.769	1-7/16
180	1/4-3/4	6.35-19.05	1.035	1-5/8

* See following page for collet ordering numbers.

DOUBLE ANGLE COLLETS

300 COLLETS		
BRIDGEPORT NO.	SIZE	
	INCH	MM
1-57-0050	1/32	.7938
1-57-0051	1/16	1.5875
1-57-0052	3/32	2.3813
1-57-0053	1/8	3.1750
1-57-0054	5/32	3.9688
1-57-0055	3/16	4.7625
1-57-0056	7/32	5.5563
1-57-0057	1/4	6.35

100 COLLETS		
BRIDGEPORT NO.	SIZE	
	INCH	MM
1-57-0090	1/4	6.35
1-57-0091	9/32	7.1438
1-57-0092	5/16	7.9375
1-57-0093	11/32	8.7313
1-57-0094	3/8	9.525
1-57-0095	13/32	10.3188
1-57-0096	7/16	11.1125
1-57-0097	15/32	11.9063
1-57-0098	1/2	12.70
1-57-0099	17/32	13.4938
1-57-0100	9/16	14.2875

180 COLLETS		
BRIDGEPORT NO.	SIZE	
	INCH	MM
1-57-0120	1/4	6.35
1-57-0121	9/32	7.1438
1-57-0122	5/16	7.9375
1-57-0123	11/32	8.7313
1-57-0124	3/8	9.525
1-57-0125	13/32	10.3188
1-57-0126	7/16	11.1125
1-57-0127	15/32	11.9063
1-57-0128	1/2	12.70
1-57-0129	17/32	13.4938
1-57-0130	9/16	14.2875
1-57-0131	19/32	15.0813
1-57-0132	5/8	15.875
1-57-0133	21/32	16.6688
1-57-0134	11/16	17.4625
1-57-0135	23/32	18.2563
1-57-0136	3/4	19.05

200 COLLETS		
1-57-0070	1/8	3.1750
1-57-0071	5/32	3.9688
1-57-0072	3/16	4.7625
1-57-0073	7/32	5.5563
1-57-0074	1/4	6.35
1-57-0075	9/32	7.1438
1-57-0076	5/16	7.9375
1-57-0077	11/32	8.7313
1-57-0078	3/8	9.525

NON-PULLOUT END MILL COLLETS
FOR USE WITH #189 CHUCK

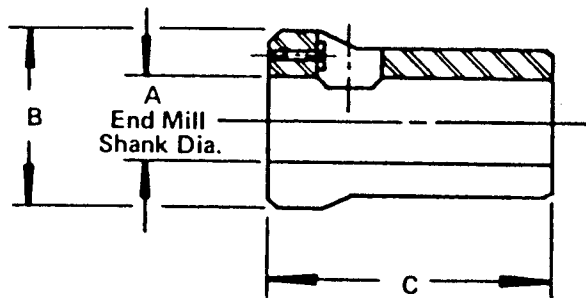

MODEL NO.	USED WITH	A		B	C	BRIDGEPORT NO.
		INCH	MM			
180 N.P.	3/4 CAP. CHUCK	3/8	9.525	1.035	1-5/8	1-57-0150
180 N.P.	3/4 CAP. CHUCK	1/2	12.70	1.035	1-5/8	1-57-0151
180 N.P.	3/4 CAP. CHUCK	5/8	15.875	1.035	1-5/8	1-57-0152
180 N.P.	3/4 CAP. CHUCK	3/4	19.05	1.035	1-5/8	1-57-0153

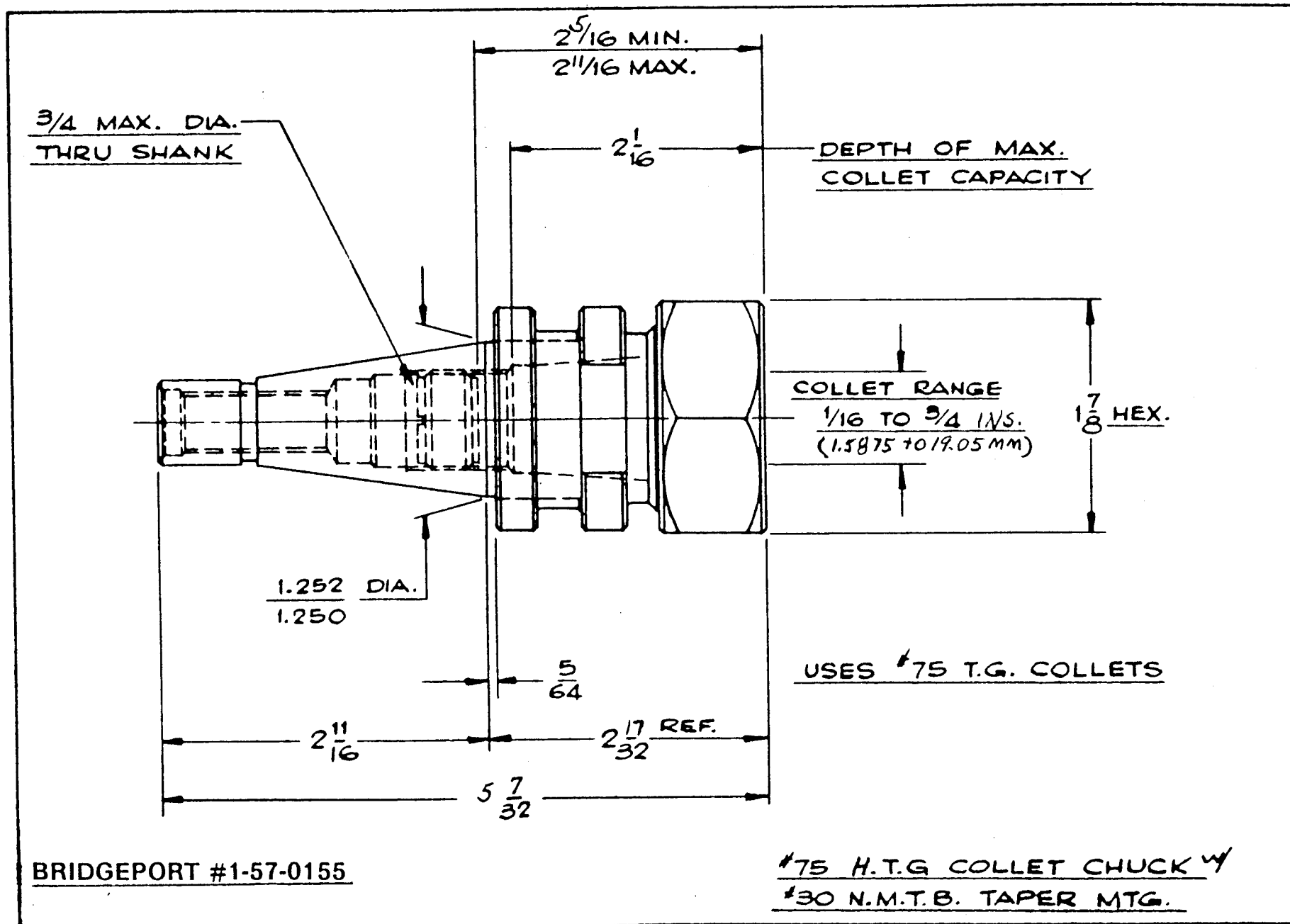

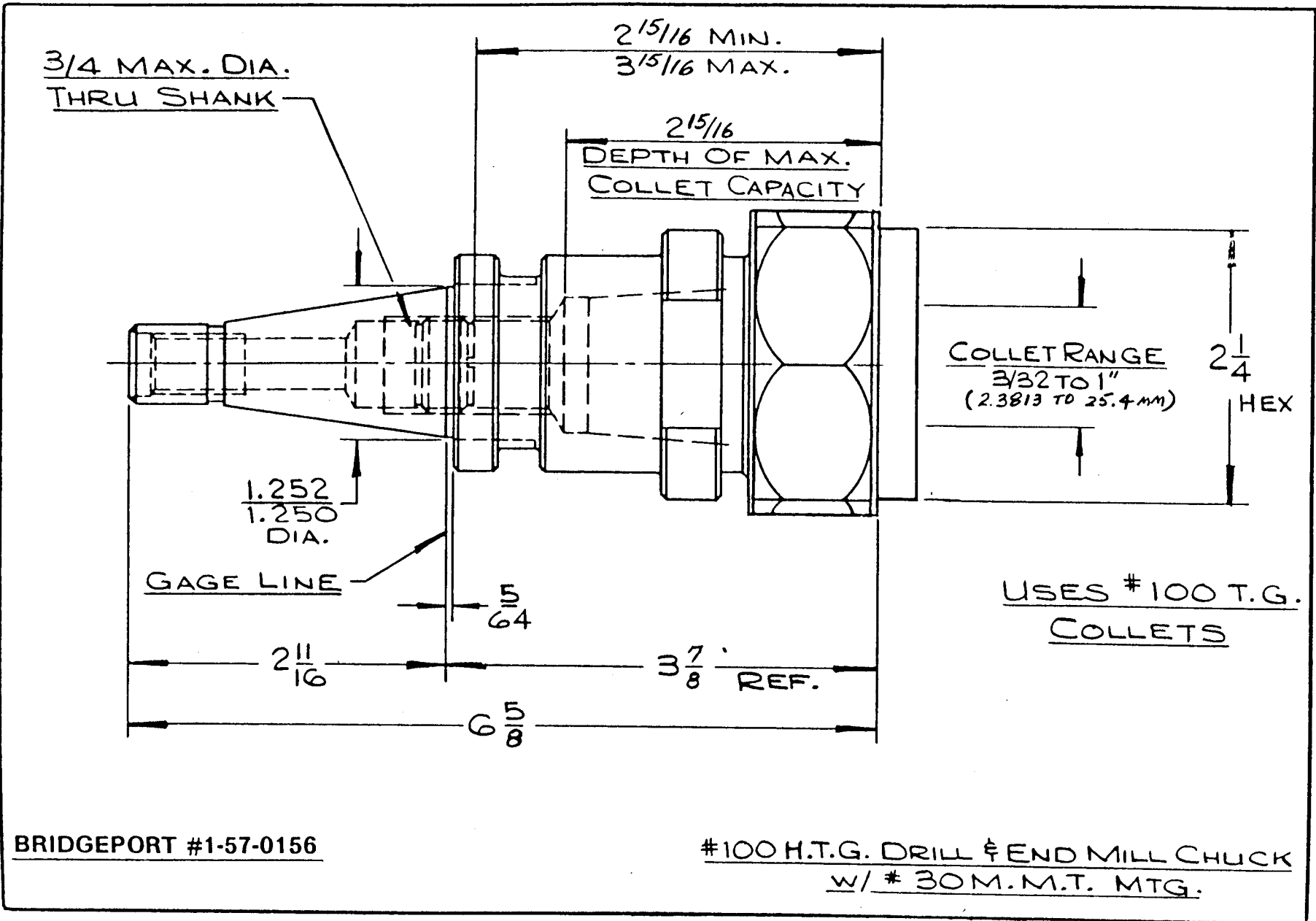

T.G. COLLETS

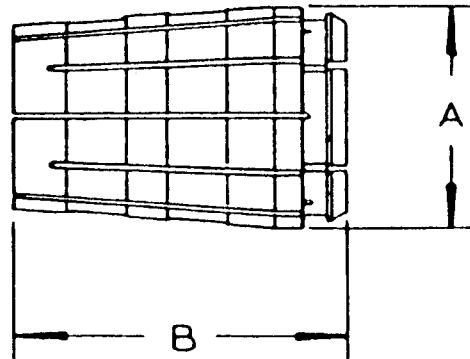

COLLET RANGE		MODEL	A	B
INCH	MM			
1/16 to 3/4	1.5875-19.05	075	1.063	1-27/32
3/32 to 1	2.3813-25.4	100	1.379	2-3/8

See next page for collet ordering numbers.

075 T.G. COLLETS

BRIDGEPORT NO.	SIZE	
	INCH	MM
1-57-0160	1/16	1.5875
1-57-0161	5/64	1.9844
1-57-0162	3/32	2.3813
1-57-0163	7/64	2.7781
1-57-0164	1/8	3.1750
1-57-0165	9/64	3.5719
1-57-0166	5/32	3.9688
1-57-0167	11/64	4.3656
1-57-0168	3/16	4.7625
1-57-0169	13/64	5.1594
1-57-0170	7/32	5.5563
1-57-0171	15/64	5.9531
1-57-0172	1/4	6.35
1-57-0173	17/64	6.7469
1-57-0174	9/32	7.1438

BRIDGEPORT NO.	SIZE	
	INCH	MM
1-57-0175	19/64	7.5406
1-57-0176	5/16	7.9375
1-57-0177	21/64	8.3344
1-57-0178	11/32	8.7313
1-57-0179	23/64	9.1281
1-57-0180	3/8	9.525
1-57-0181	25/64	9.9219
1-57-0182	13/32	10.3188
1-57-0183	27/64	10.7156
1-57-0184	7/16	11.1125
1-57-0185	29/64	11.5094
1-57-0186	15/32	11.9063
1-57-0187	31/64	12.3031
1-57-0188	1/2	12.70
1-57-0189	33/64	13.0969

BRIDGEPORT NO.	SIZE	
	INCH	MM
1-57-0190	17/32	13.4938
1-57-0191	35/64	13.8906
1-57-0192	9/16	14.2875
1-57-0193	37/64	14.6844
1-57-0194	19/32	15.0813
1-57-0195	39/64	15.4781
1-57-0196	5/8	15.875
1-57-0197	41/64	16.2719
1-57-0198	21/32	16.6688
1-57-0199	43/64	17.0656
1-57-0200	11/16	17.4625
1-57-0201	45/64	17.8594
1-57-0202	23/32	18.2563
1-57-0203	47/64	18.6531
1-57-0204	3/4	19.05

100 T.G. COLLETS

BRIDGEPORT NO.	SIZE		BRIDGEPORT NO.	SIZE		BRIDGEPORT NO.	SIZE	
	INCH	MM		INCH	MM		INCH	MM
1-57-0220	3/32	2.3813	1-57-0240	13/32	10.3188	1-57-0260	23/32	18.2563
1-57-0221	7/64	2.7781	1-57-0241	27/64	10.7156	1-57-0261	47/64	18.6531
1-57-0222	1/8	3.175	1-57-0242	7/16	11.1125	1-57-0262	3/4	19.05
1-57-0223	9/64	3.5719	1-57-0243	29/64	11.5094	1-57-0263	49/64	19.4469
1-57-0224	5/32	3.9688	1-57-0244	15/32	11.9063	1-57-0264	25/32	19.8438
1-57-0225	11/64	4.3656	1-57-0245	31/64	12.3031	1-57-0265	51/64	20.2406
1-57-0226	3/16	4.7625	1-57-0246	1/2	12.70	1-57-0266	13/16	20.6375
1-57-0227	13/64	5.1594	1-57-0247	33/64	13.0969	1-57-0267	53/64	21.0344
1-57-0228	7/32	5.5563	1-57-0248	17/32	13.4938	1-57-0268	27/32	21.4313
1-57-0229	15/64	5.9531	1-57-0249	35/64	13.8906	1-57-0269	55/64	21.8281
1-57-0230	1/4	6.35	1-57-0250	9/16	14.2875	1-57-0270	7/8	22.225
1-57-0231	17/64	6.7469	1-57-0251	37/64	14.6844	1-57-0271	57/64	22.6219
1-57-0232	9/32	7.1438	1-57-0252	19/32	15.0813	1-57-0272	29/32	23.0188
1-57-0233	19/64	7.5406	1-57-0253	39/64	15.4781	1-57-0273	59/64	23.4156
1-57-0234	5/16	7.9375	1-57-0254	5/8	15.875	1-57-0274	15/16	23.8125
1-57-0235	21/64	8.3344	1-57-0255	41/64	16.2719	1-57-0275	61/64	24.2094
1-57-0236	11/32	8.7313	1-57-0256	21/32	16.6688	1-57-0276	31/32	24.6063
1-57-0237	23/64	9.1281	1-57-0257	43/64	17.0656	1-57-0277	63/64	25.0031
1-57-0238	3/8	9.525	1-57-0258	11/16	17.4625	1-57-0278	1"	25.40
1-57-0239	25/64	9.9219	1-57-0259	45/64	17.8594			

NON-PULLOUT END MILL COLLETS
FOR USE WITH T.G. & H.T.G. CHUCKS

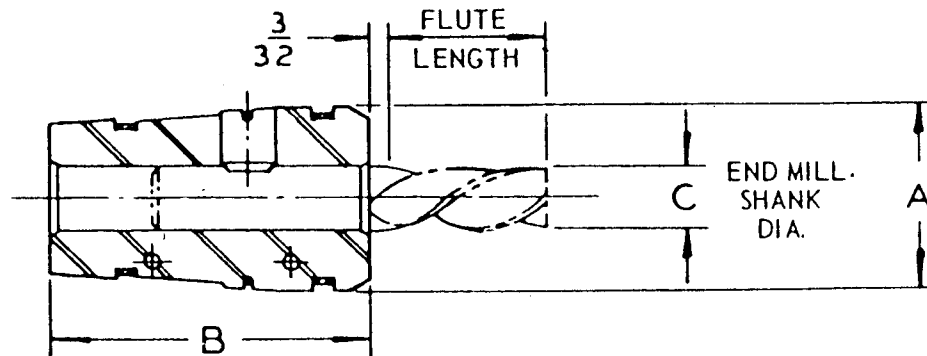
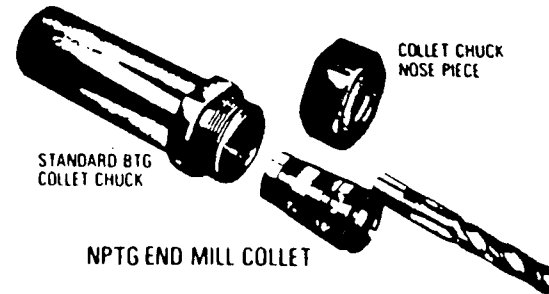

MODEL NO.	USED WITH	A	B	C		BRIDGEPORT NO.
				INCH	MM	
075 N.P.T.G.	3/4" Cap. Chuck	1.063	1-27/32	3/8	9.525	1-57-0300
075 N.P.T.G.	3/4" Cap. Chuck	1.063	1-27/32	1/2	12.70	1-57-0301
075 N.P.T.G.	3/4" Cap. Chuck	1.063	1-27/32	5/8	15.875	1-57-0302
100 N.P.T.G.	1" Cap. Chuck	1.379	2-3/8	3/8	9.525	1-57-0305
100 N.P.T.G.	1" Cap. Chuck	1.379	2-3/8	1/2	12.70	1-57-0306
100 N.P.T.G.	1" Cap. Chuck	1.379	2-3/8	5/8	15.875	1-57-0307
100 N.P.T.G.	1" Cap. Chuck	1.379	2-3/8	3/4	19.05	1-57-0308
100 N.P.T.G.	1" Cap. Chuck	1.379	2-3/8	1"	25.40	1-57-0309

TENTHSET BORING BARS

BORING HEAD NO.	BORING BAR DIA.	BORING BAR LENGTH	BRIDGEPORT NO.
#37	.375	1.500	1-57-0312
#37	.375	3.000	1-57-0313
#37	.375	5.000	1-57-0314
#50	.500	2.000	1-57-0315
#50	.500	4.000	1-57-0316
#50	.500	6.500	1-57-0317

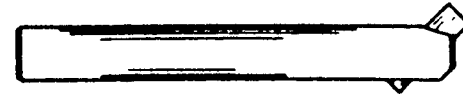

TENTHSET BORING CUTTERS

BORING HEAD NO.	MINIMUM BORE	MAXIMUM DEPTH	BRIDGEPORT NO.
#37	.18	.56	1-57-0320
#37	.18	.94	1-57-0321
#37	.25	.75	1-57-0322
#37	.25	1.25	1-57-0323
#37	.31	.94	1-57-0324
#37	.31	1.56	1-57-0325
#37	.37	1.12	1-57-0326
#37	.37	1.88	1-57-0327
#50	.25	.75	1-57-0328
#50	.25	1.25	1-57-0329
#50	.31	.94	1-57-0330
#50	.31	1.56	1-57-0331
#50	.37	1.12	1-57-0332
#50	.37	1.88	1-57-0333
#50	.44	1.31	1-57-0334
#50	.44	2.18	1-57-0335
#50	.50	1.50	1-57-0336
#50	.50	2.50	1-57-0337



NOTE: CARBIDE TIPPED CUTTERS AVAILABLE ON REQUEST.

END MILL
ADAPTERS
W/ #30 M.M.T. MTG.

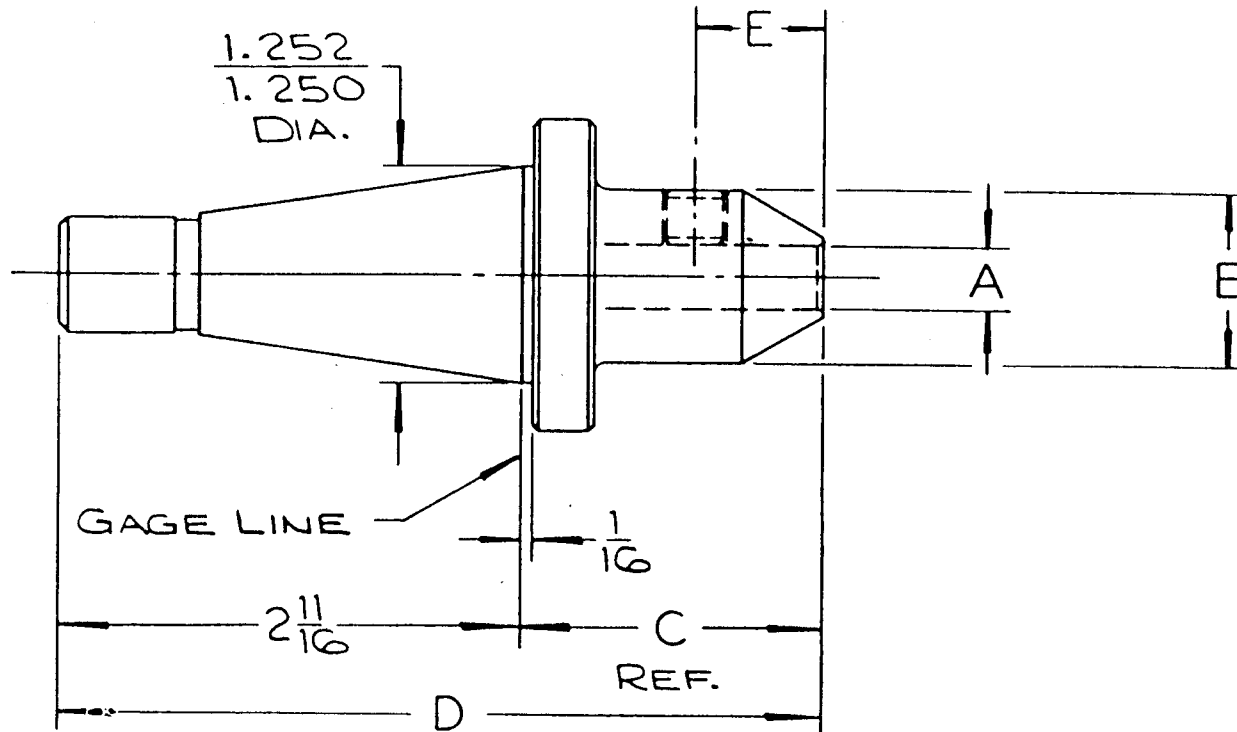

A	B	C	D	E	END MILL	BRIDGEPORT NO.
$\frac{3}{16}$	$\frac{11}{16}$	$1\frac{3}{4}$	$4\frac{7}{16}$	$\frac{9}{16}$	SINGLE OR DOUBLE	1-57-0340
$\frac{3}{8}$	$1\frac{1}{8}$	$1\frac{3}{4}$	$4\frac{7}{16}$	$\frac{3}{4}$	SINGLE OR DOUBLE	1-57-0341
$\frac{1}{2}$	$1\frac{1}{4}$	$1\frac{3}{4}$	$4\frac{7}{16}$	$\frac{7}{8}$	SINGLE	1-57-0342
$\frac{5}{8}$	$1\frac{7}{16}$	$1\frac{3}{4}$	$4\frac{7}{16}$	$1\frac{5}{16}$	SINGLE	1-57-0343
$\frac{3}{4}$	$1\frac{13}{16}$	$2\frac{1}{8}$	$4\frac{13}{16}$	$1\frac{1}{8}$	SINGLE	1-57-0344
$\frac{7}{8}$	$1\frac{7}{8}$	$2\frac{1}{2}$	$5\frac{3}{16}$	$1\frac{1}{8}$	SINGLE	1-57-0345
$1\frac{1}{8}$	$2\frac{1}{8}$	$2\frac{11}{16}$	$5\frac{3}{8}$	$1\frac{1}{8}$	SINGLE	1-57-0346

SHELL MILL
ADAPTERS w/
#30 M.M.T. MTG.

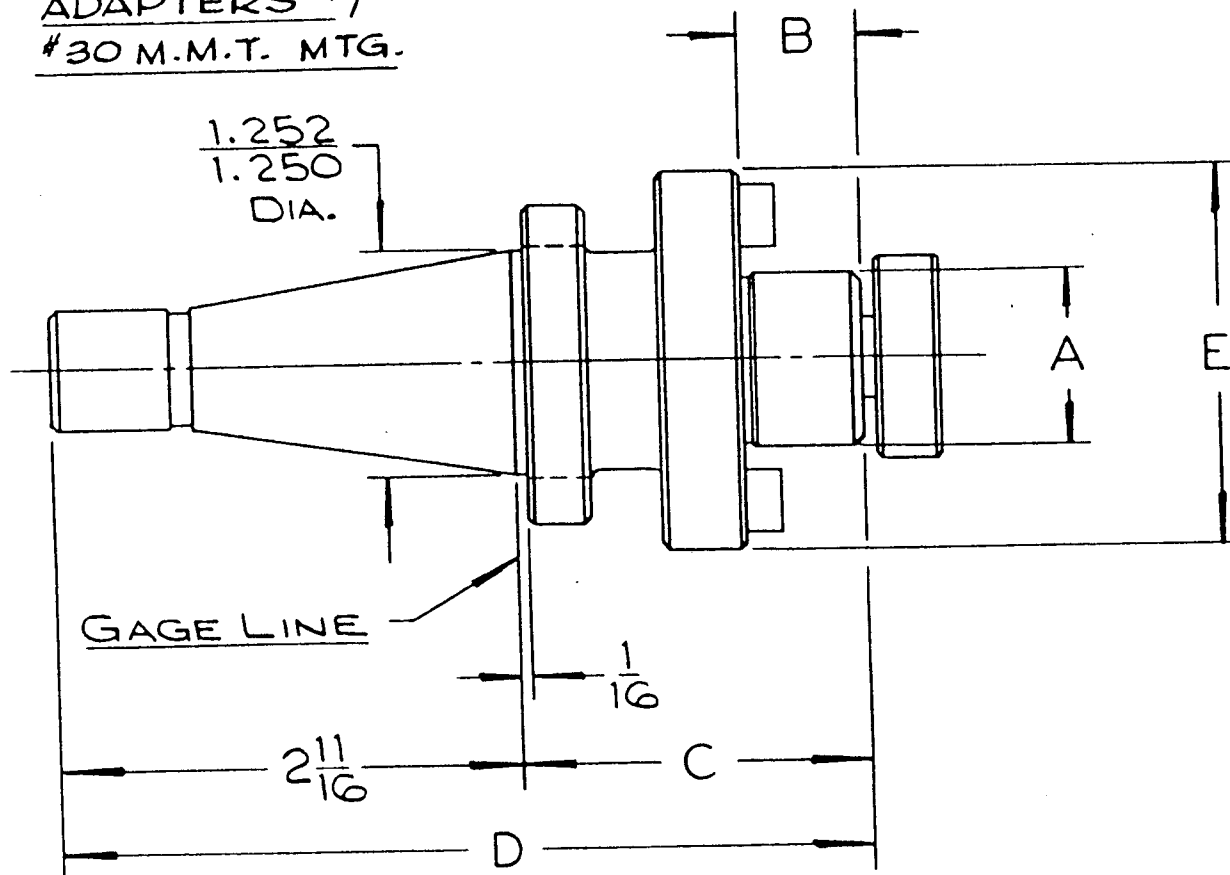

A	B	C	D	E	BRIDGEPORT NO.
.500	9/16	1 13/16	4 1/2	1 7/16	1-57-0350
.750	11/16	2 IN.	4 11/16	1 3/4	1-57-0351
1.000	11/16	2 IN.	4 11/16	2 3/16	1-57-0352

MORSE TAPER
ADAPTERS
N/130 M.M.T. MTG.

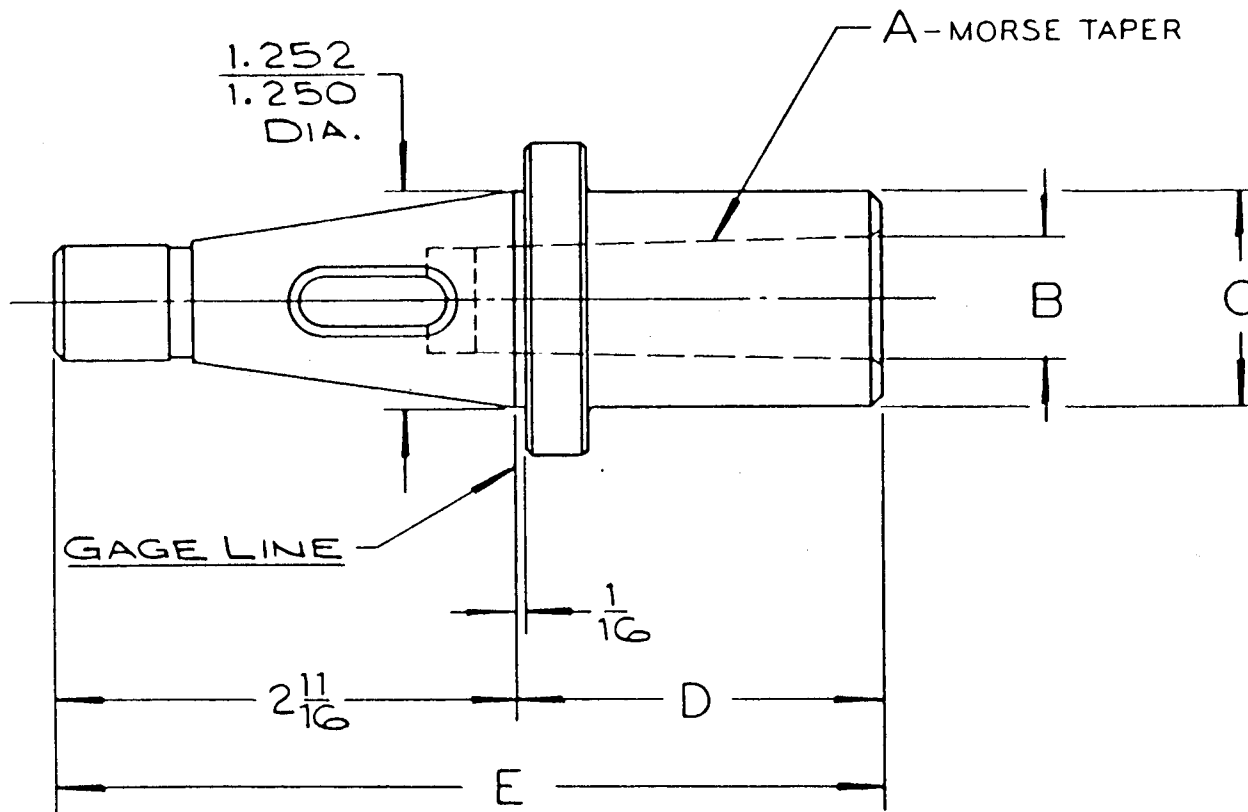

23

A	B	C	D	E	BRIDGEPORT NO.
*1	.475	1 1/4	1 1/4	3 11/16	1-57-0360
*2	.700	1 1/4	2 1/8	4 13/16	1-57-0361
*3	.938	1 3/8	2 13/16	5 1/2	1-57-0362

JACOBS TAPER
ADAPTERS W/
#30 M.M.T. MTG.

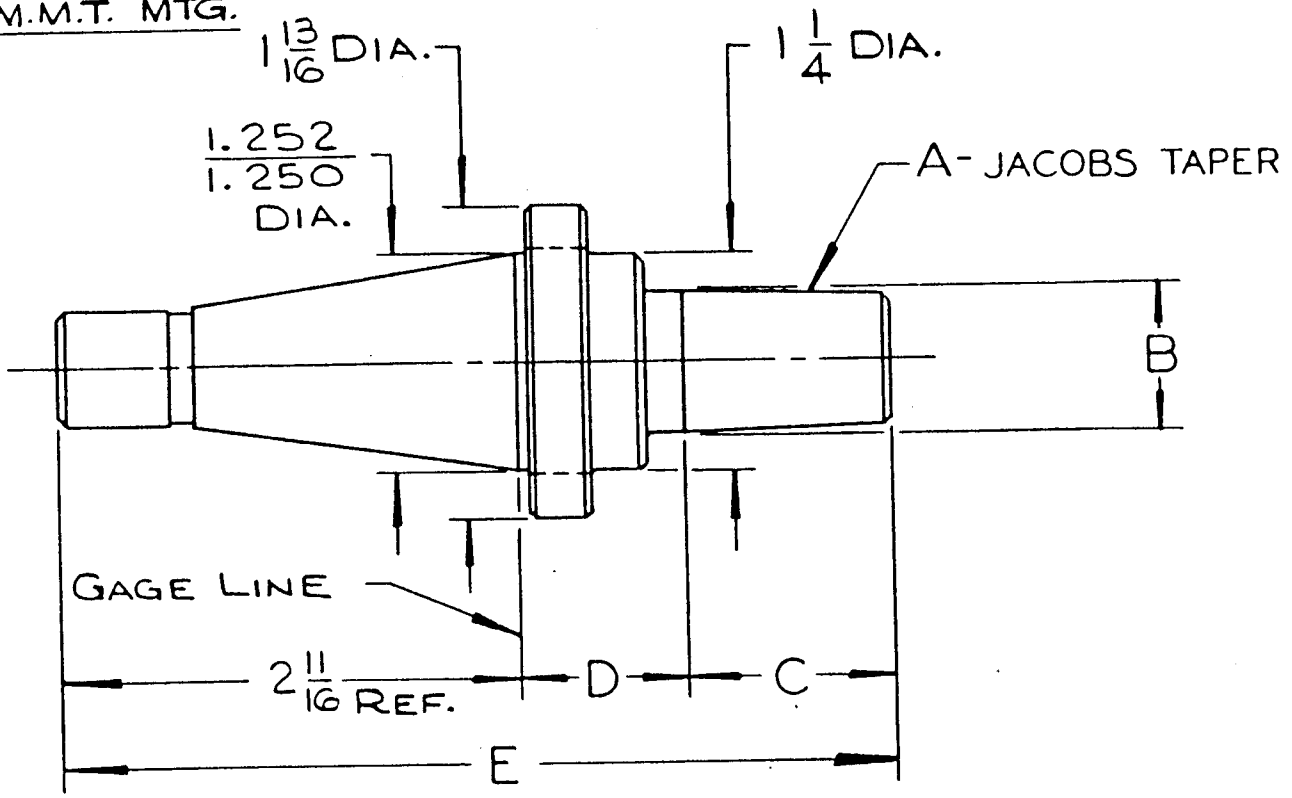

214

A	B	C	D	E	BRIDGEPORT NO.
#3	.812	1-7/32	3/32	4-7/8	1-57-0370
#4	1.125	1-21/32	3/32	5-5/16	1-57-0371
#6	.677	1 IN.	3/32	4-21/32	1-57-0372

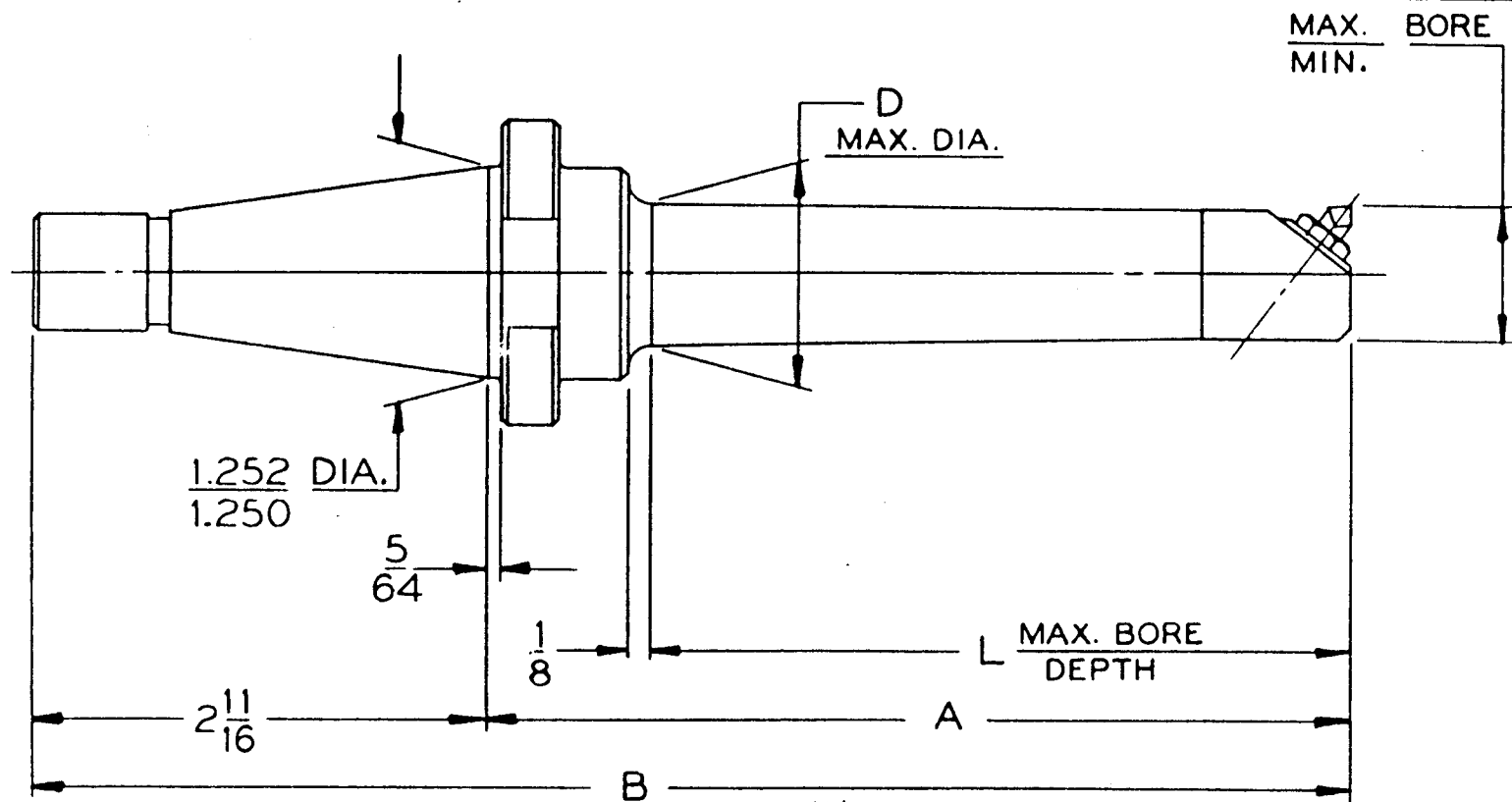

SINGLE TOOL BORING BARS, ANGULAR MOUNTED ^{W/} 30 N.M.T.B. TAPER MTG.

A	B	D	L	BORING RANGE		CARTRIDGE UNIT SPECIFICATION				BRIDGEPORT NO.
				MIN.	MAX.	SIZE	LENGTH	STYLE	DIAL GRAD.	
$3\frac{27}{64}$	$6\frac{7}{64}$	$2\frac{9}{64}$	$2\frac{5}{8}$	$\frac{1}{2}$	$\frac{19}{32}$	1	S(SHORT)	2	30	1-57-0380
$3\frac{27}{64}$	$6\frac{7}{64}$	$3\frac{3}{64}$	$2\frac{5}{8}$	$\frac{9}{16}$	$\frac{23}{32}$	1	L(LONG)	2	30	1-57-0381
$4\frac{1}{64}$	$6\frac{55}{64}$	$4\frac{7}{64}$	$3\frac{3}{8}$	$\frac{3}{4}$	$\frac{15}{16}$	2	S(SHORT)	2	40	1-57-0382
$4\frac{59}{64}$	$7\frac{39}{64}$	$2\frac{7}{32}$	$4\frac{1}{8}$	$\frac{55}{64}$	$\frac{13}{64}$	2	L(LONG)	2	40	1-57-0383
$5\frac{19}{64}$	$7\frac{63}{64}$	$1\frac{5}{32}$	$4\frac{1}{2}$	$1\frac{1}{64}$	$1\frac{47}{64}$	3	L(LONG)	2	40	1-57-0384
$5\frac{19}{64}$	$7\frac{63}{64}$	$1\frac{5}{8}$	$4\frac{1}{2}$	$1\frac{23}{32}$	$2\frac{1}{2}$	5	L(LONG)	2	40	1-57-0385
$5\frac{51}{64}$	$8\frac{31}{64}$	$2\frac{1}{4}$	$5\frac{1}{2}$	$2\frac{13}{32}$	$3\frac{21}{32}$	7	L(LONG)	2	80	1-57-0386

1/2" TENSION

HOLDER CAPACITY:

*0 THRU 1/4 TAPS

(#0 THRU 6.35 MM TAPS)

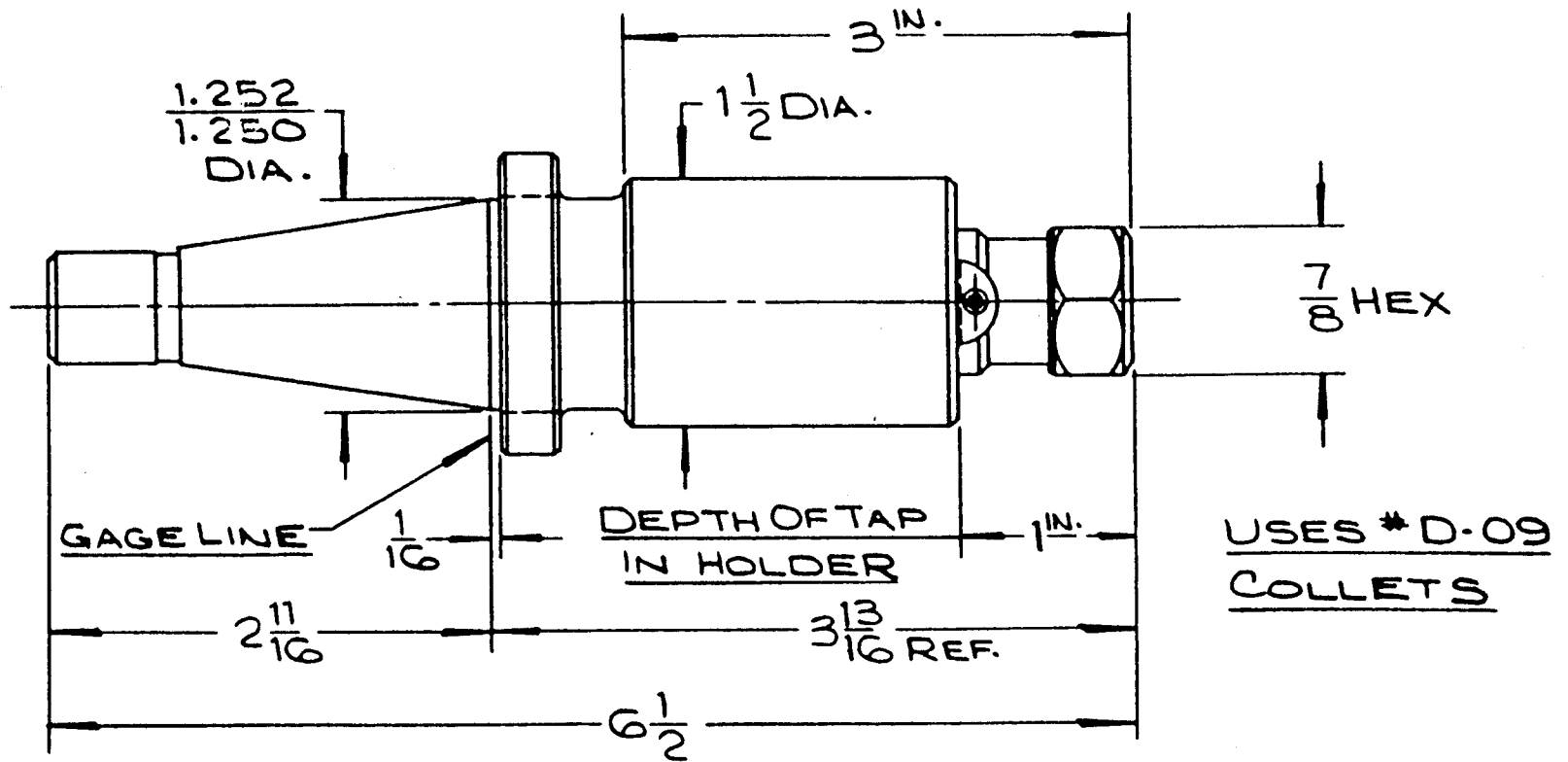

26

BRIDGEPORT #1-57-0400

D-09 TENSION TYPE TAP HOLDER
W/ # 30 M.M.T. MTG.

1/2" TENSION ~ 1/2" COMPRESSION

HOLDER CAPACITY:

* 0 THRU 1/4 TAPS
(# 0 THRU 6.35 MM TAPS)

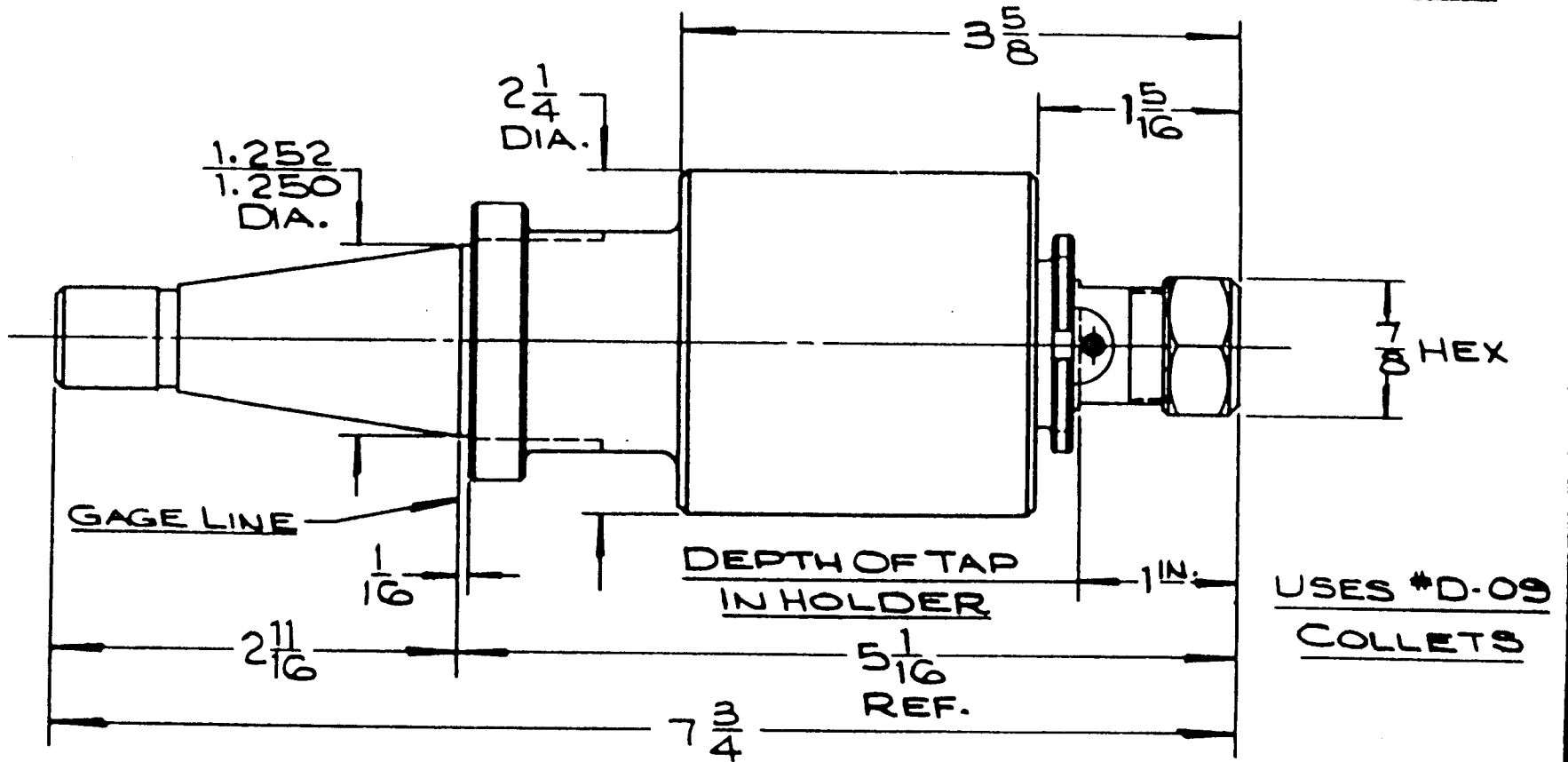

USES #D-09
COLLETS

BRIDGEPORT #1-57-0401

#D-09 TENSION & COMPRESSION
'SAFE-DRIVE' TAP HOLDER w/ #30 M.M.T. MTG.

1/2" TENSION

HOLDER CAPACITY:

1/4 THRU 7/8 HAND TAP (6.35 THRU 22.225 MM)

1/16 THRU 1/2 PIPE TAP

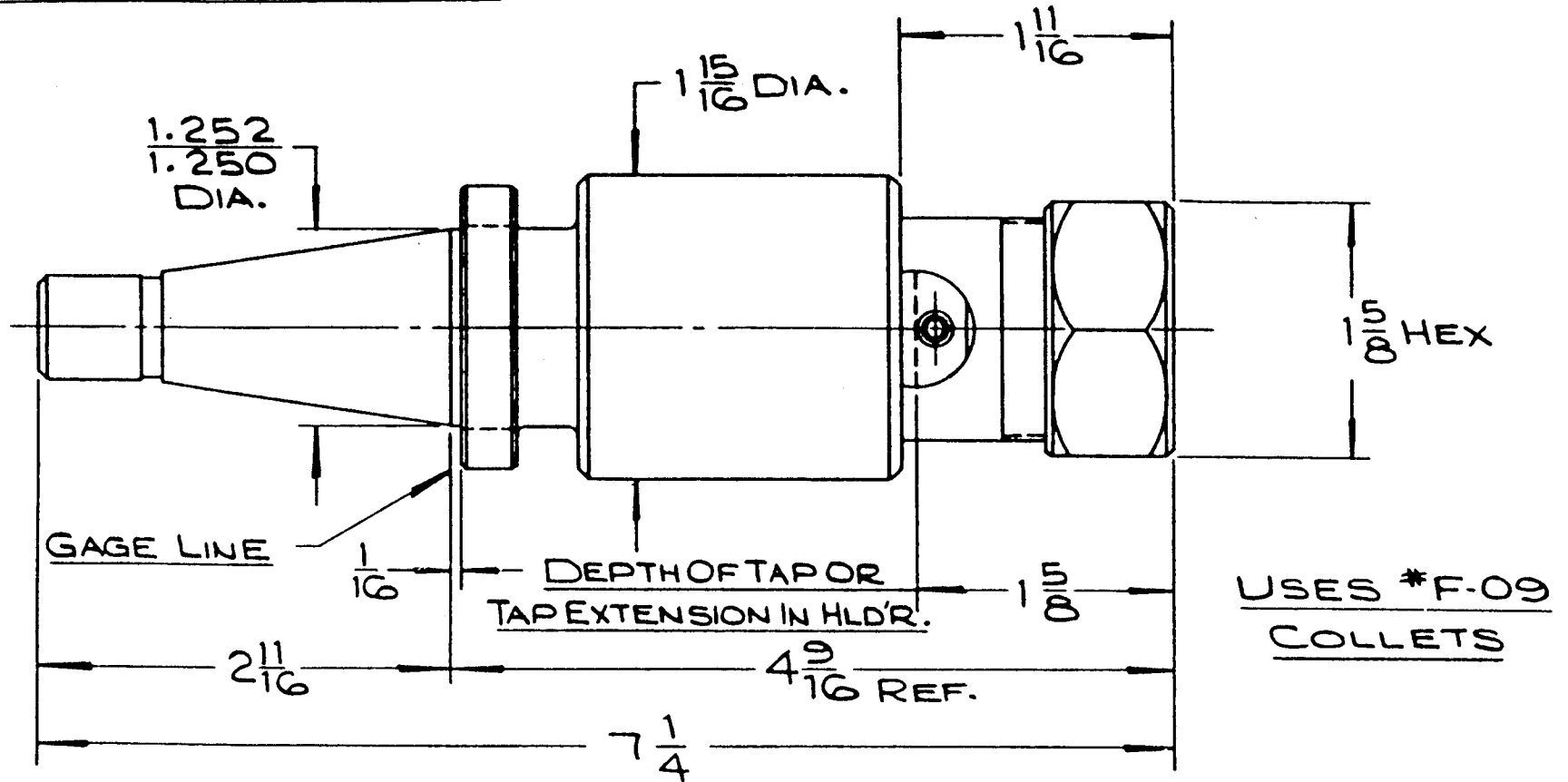

28

BRIDGEPORT #1-57-0402

#F-09 TENSION TYPE TAP HOLDER
W/#30 M.M.T. MTG.

1/2" TENSION ~ 1/2" COMPRESSION

HOLDER CAPACITY:
1/4 THRU 7/8 HAND TAP
(6.35 THRU 22.225 MM)

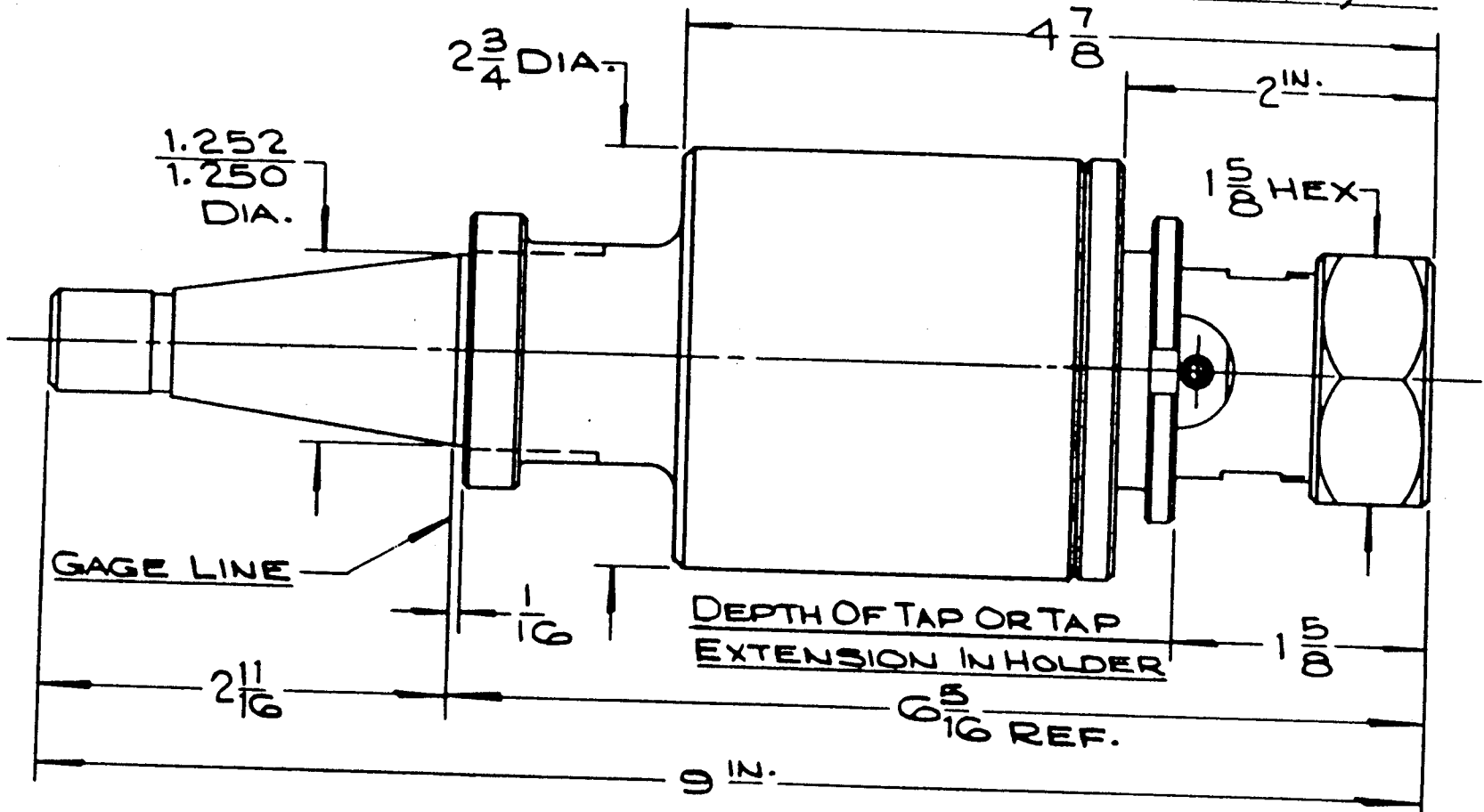

USES #F-09
COLLETS

BRIDGEPORT #1-57-0403

#F-09 TENSION & COMPRESSION 'SAFE-DRIVE'
TAP HOLDER W/ #30 M.M.T. MTG.

TAP COLLETS

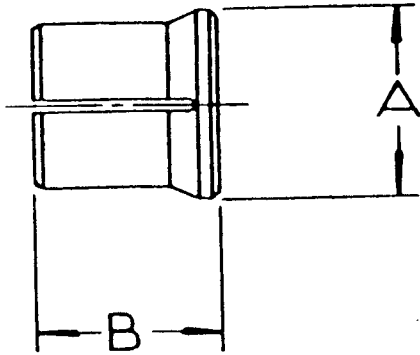

COLLET RANGE	MODEL	A	B
#0 THRU 1/4	D-09	.539	5/8
1/4 THRU 7/8	F-09	1.107	1-3/32
3/4 THRU 1-1/2	G-09	1.813	1-3/16

D-09 #0 THRU 1/4 TAPS			
TAP SIZE	HOLE SIZE		BRIDGEPORT NO.
	INCH	MM	
#0 thru #6	.141	3.5814	1-57-0410
#8	.168	4.2672	1-57-0411
#10	.194	4.9276	1-57-0412
#12	.220	5.588	1-57-0413
#14 & 1/4	.255	6.477	1-57-0414

F-09 1/4 THRU 7/8 TAPS			
TAP SIZE	HOLE SIZE		BRIDGEPORT NO.
	INCH	MM	
1/4	.255	6.477	1-57-0430
5/16	.318	8.0772	1-57-0431
7/16	.323	8.2042	1-57-0432
1/2	.367	9.3218	1-57-0433
3/8	.381	9.6774	1-57-0434
9/16	.429	10.8966	1-57-0435
5/8	.480	12.1920	1-57-0436
3/4	.590	14.986	1-57-0437
7/8	.697	17.7038	1-57-0438
1/16 pipe	.313		1-57-0439
1/8 pipe	.438		1-57-0440
1/4 pipe	.563		1-57-0441
3/8 pipe	.700		1-57-0442
1/2 pipe	.698		1-57-0443

G-09 3/4 THRU 1-1/2 TAPS			
TAP SIZE	HOLE SIZE		BRIDGEPORT NO.
	INCH	MM	
3/4	.590	14.986	1-57-0450
7/8	.697	17.7038	1-57-0451
1"	.800	20.32	1-57-0452
1-1/8	.896	22.7584	1-57-0453
1-1/4	1.021	25.9334	1-57-0454
1-3/8	1.108	28.1434	1-57-0455
1-1/2	1.233	31.3182	1-57-0456
3/8 pipe	.700		1-57-0457
1/2 pipe	.688		1-57-0458
5/8 pipe	.813		1-57-0459
3/4 pipe	.906		1-57-0460
7/8 pipe	1.094		1-57-0461
1" pipe	1.125		1-57-0462
1-1/4 pipe	1.313		1-57-0463

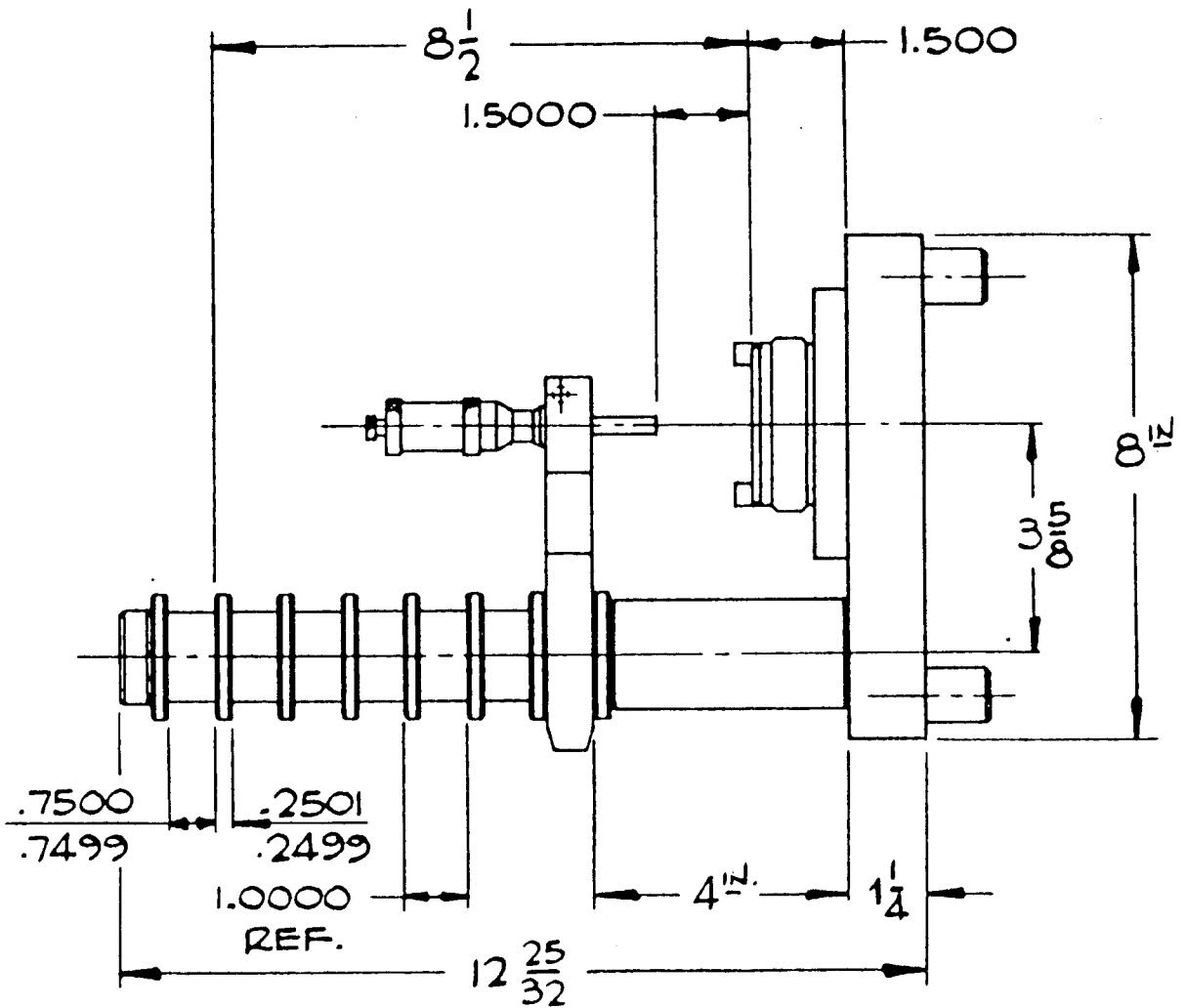
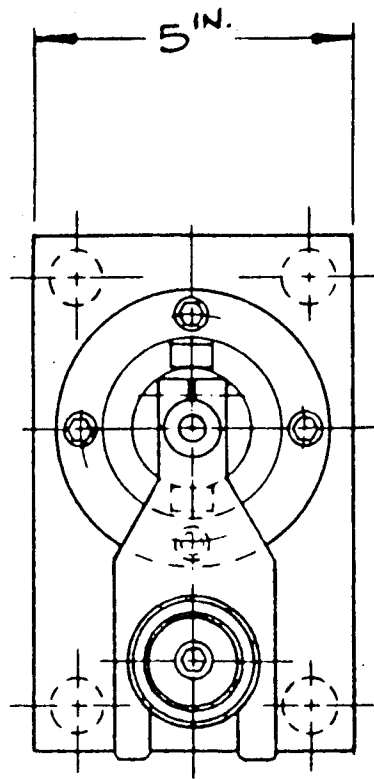

BRIDGEPORT #1-57-0480

PRE SET FIXTURE W/
Nº 30 M.M.T. SOCKET

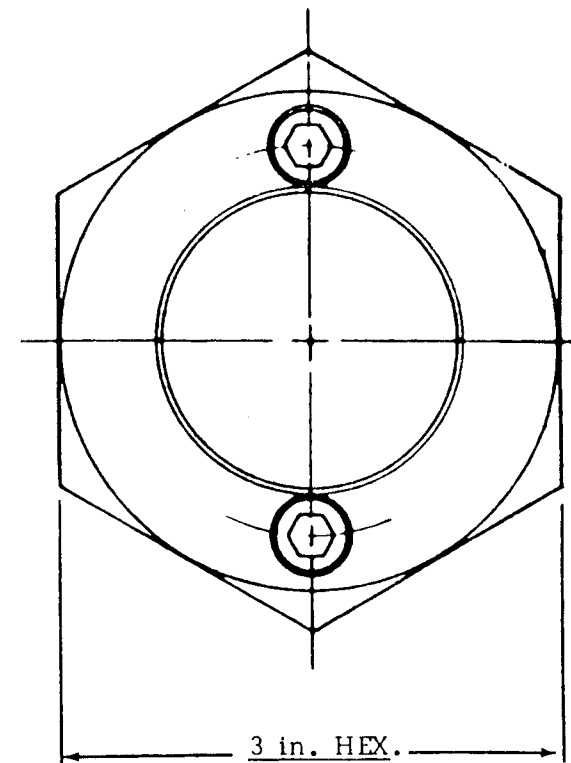
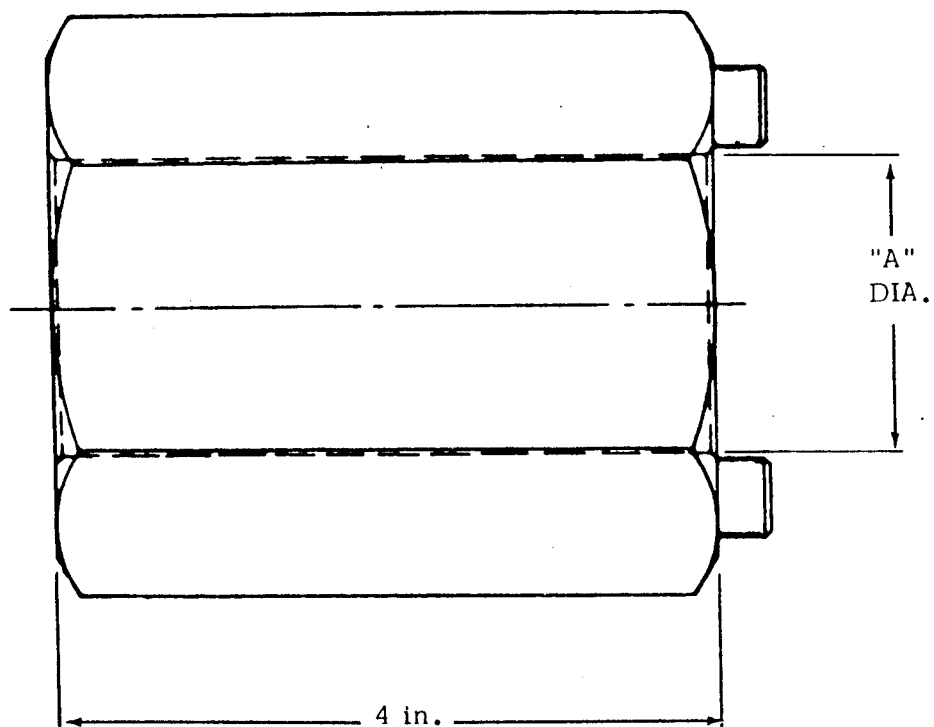

TIGHTENING FIXTURE

MODEL	"A"	BRIDGEPORT No.
#30	1.260	1-57-2335
#40	1.760	1-57-2336