

RUBBER BUSHES

By GEOMETER

THE resilience and shock-absorbing properties of rubber, making it especially suitable for mountings of engines, motors and major components, render it no less useful in numerous minor situations where static bushes are required to give protection, and where movement through a small arc is involved. There is also the advantage, over ordinary metal bushes, that no lubrication is necessary—all movement being accommodated in the rubber itself.

Used for protection or as a draught or weather excluder, a rubber bush—usually called a grommet or ferrule—is moulded with a pair of flanges to keep it in position. Common applications are to pipes, control cables or groups of wires where these necessarily pass through metal panels or bulkheads, as on road vehicles.

Size may vary, as at **A**, from a button for a small pipe to a fairly large disc for a sizable conduit or harness with several wires. Where fitting to a pipe or wires already in position would entail considerable dismantling for a grommet or ferrule to be slipped over an end, it can be slit and clipped on, then worked into the hole in the panel and using a smear of wet soap if necessary.

Working bushes carrying loads and accommodating small angular movements may be plain, flanged or moulded in metal housings or sleeves (silentbloc variety), choice of type depending on the function required.

In mountings, as at **B**, flanged bushes are used for swinging links or shackles on leaf springs of road vehicles, obviating lubrication and insulating chassis and body to some extent from tyre and suspension noise. Shackle pins have shoulders, and side-plates are pulled up to these by nuts.

In other mountings one shackle pin only works with rubber bushes, the other in the chassis having a metal bush. The rubber bushes mainly reduce noise, since the pin in the metal bush needs to be lubricated. The arrangement, however, limits side movement or sway occurring with two pins in rubber bushes, owing to flexibility.

To avoid such flexibility bushes employed for fixed ends of leaf springs are metal or silentbloc type, as at **C**. This bush consists of inner and outer steel sleeves, rubber filled.

The outer sleeve is the width of the spring leaf while the inner is longer for clearance. On each side of this spigot portion a fibre washer may be fitted, and the shackle bolt-passing through the mounting brackets-tightens these to the inner sleeve.

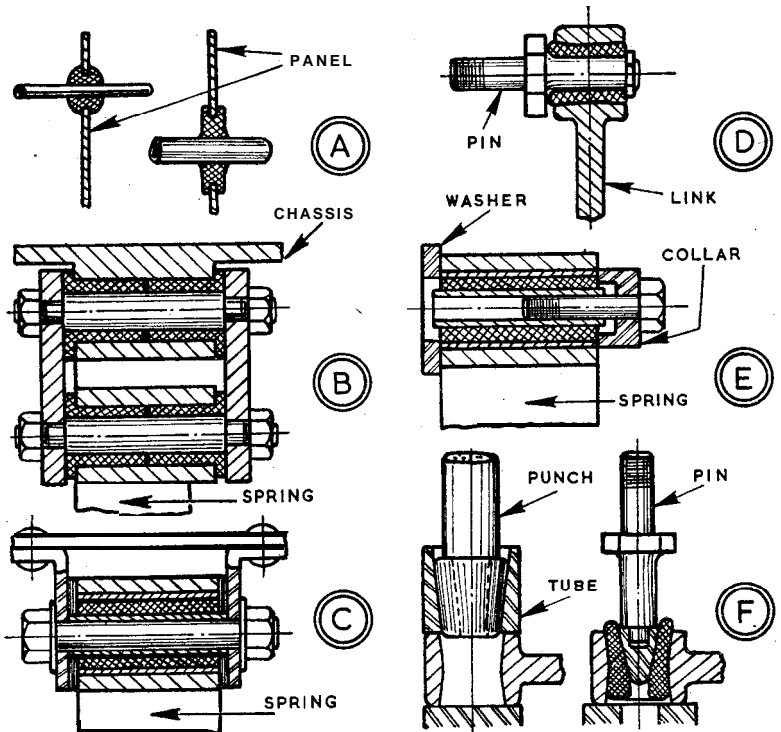

A plain bush fitting for a shock-absorber linkage can be as at **D**, each boss of the link containing a rubber bush with a pin which may have a washer on its riveted-over end. The pins are then attached by the shanks to the shock absorber arms, and the axle or spring mountings.

Removal and fitting of rubber bushes is straightforward. To avoid wringing, vehicles should be jacked up the same each side in order to take the weight for the pins to be removed. Flanged bushes can be extracted and fitted by hand. But force, as from a draw bolt and tubing, is required for silentbloc types, taking care, however, to avoid pressure on the inner sleeves if such bushes are to be used again.

A collar to suit the bolt, stepped one end, and passing easily through the spring eye may be employed for removal—and also for fitting, using the vice, as at **E**, with a short guide bolt and a clearance washer at the opposite end.

In fitting springs with rubber bushes to vehicles, particularly silentbloc types, shackle-pin nuts should be loose until after unjacking so that the bushes may be tightened in the working attitude without torsional stress on the rubber.

Bushes for links can be fitted, as at **F**, using a tapered tube and punch to compress each into the link, and a rounded nose on the pin while this is forced through with soap or rubber grease as lubricant.